



# OWNER'S MANUAL

## *Mongoose 70S*

*OFF-ROAD*

- Do not remove this Owner's Manual from this ATV according to the guidelines and agreement with the U.S. Consumer Product Safety Commission.
- Read this manual carefully. It contains important safety information.

**⚠ WARNING**

**UNDER 6**

Operation of this ATV by children under the age of 6 increases the risk of severe injury or death.

Adult supervision required for children under age 16.

**NEVER** permit children under age 6 to operate this ATV.

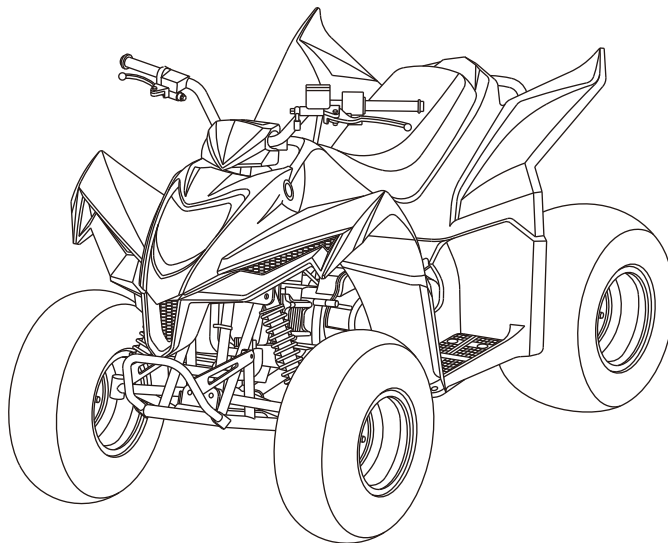

KYMCO is certificated to ISO9001, ISO13485, ISO14001, OHSAS18001, etc.; and accredited to ISO17025. Details at <http://www.kymco.com/>



**⚠ WARNING**

**Improper ATV use can result in SEVERE INJURY or DEATH**

			
<b>ALWAYS USE AN APPROVED HELMET AND PROTECTIVE GEAR</b>	<b>NEVER USE ON PUBLIC ROADS</b>	<b>NEVER CARRY PASSENGERS</b>	<b>NEVER USE WITH DRUGS OR ALCOHOL</b>

**NEVER operate:**

- without proper training or instruction
- at speeds too fast for your skills or the conditions
- on public roads - a collision can occur with another vehicle
- with a passenger - passengers affect balance and steering and increase risk of losing control

**ALWAYS:**

- use proper riding techniques to avoid vehicle overturns on hills and rough terrain and in turns
- avoid paved surfaces - pavement may seriously affect handling and control

**LOCATE AND READ OWNER'S MANUAL.  
FOLLOW ALL INSTRUCTIONS AND WARNINGS**

87520-PV11-M35

Part No. T200-LA15CA-A7  
Issued: Apr. 2014

## LOCATION OF THE WARNING AND SPECIFICATION LABELS

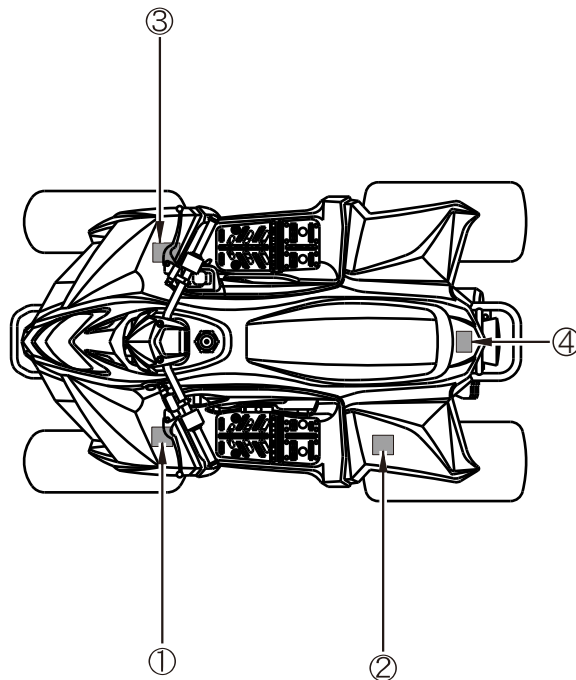

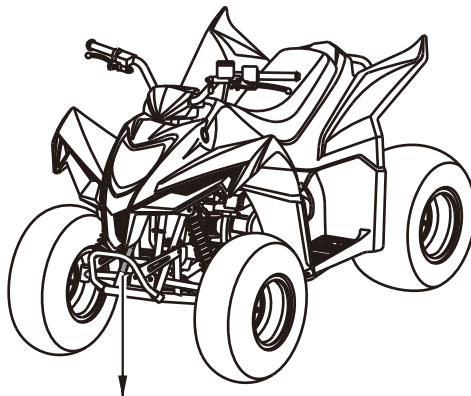

Manufactured by KWANG YANG MOTOR CO., LTD. (KYMCO)  
KWANG YANG MOTOR CO., LTD. (KYMCO) certifies that this  
ATV complies with the American National Standard for Four  
Wheel All-Terrain Vehicles, ANSI/SVIA-1-2010 Standard, and  
is subject to the KYMCO Action Plan on file with the U.S.  
Consumer Product Safety Commission.

**87666-LEG2-M30**

## WARNING INFORMATION

Your ATV comes with a hang tag and several labels containing important safety information. Anyone who rides the vehicle should read and understand this information before riding.

Parents of young riders should make sure their youngsters read and understand the hang tag and label information before allowing them to ride.

The labels should be considered as permanent parts of the vehicle. If a label comes off or becomes hard to read, contact your KYMCO dealer for replacements

## HANG TAG GENERAL USE

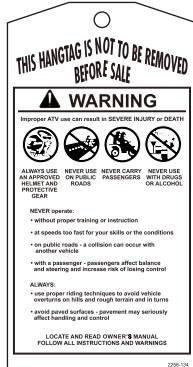

Front

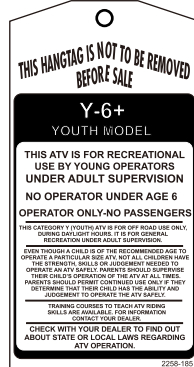

Reverse side

①

**⚠ WARNING**

Improper ATV use can result in SEVERE INJURY or DEATH



ALWAYS USE AN APPROVED HELMET AND PROTECTIVE GEAR



NEVER USE ON PUBLIC ROADS



NEVER CARRY PASSENGERS



NEVER USE WITH DRUGS OR ALCOHOL

**NEVER** operate:

- without proper training or instruction
- at speeds too fast for your skills or the conditions
- on public roads - a collision can occur with another vehicle
- with a passenger-passengers affect balance and steering and increase risk of losing control

**ALWAYS:**

- use proper riding techniques to avoid vehicle overturns on hills and rough terrain and in turns
- avoid paved surfaces - pavement may seriously affect handling and control

**LOCATE AND READ OWNER'S MANUAL FOLLOW ALL INSTRUCTIONS AND WARNINGS**

1416-020

②

**⚠ WARNING**

Improper tire pressure or overloading can cause loss of control. Loss of control can result in severe injury or death.

- Cold tire pressure:
  - Front: **3.0 psi (20.6 kPa)**
  - Rear: **3.0 psi (20.6 kPa)**
- Maximum weight capacity: **175 lbs (79 kg)**

1411-938

③

**⚠ WARNING**

**UNDER 6**

**Operation of this ATV by children under the age of 6 increases the risk of severe injury or death.**

Adult supervision required for children under age **16**.

**NEVER** permit children under age **6** to operate this ATV.

④

**⚠ WARNING**

**NEVER** ride as a passenger.

Passengers can cause a loss of control, resulting in **SEVERE INJURY** or **DEATH**.

1411-809

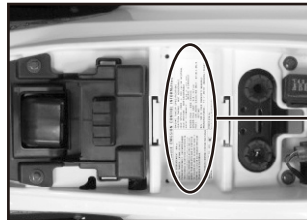

**VEHICLE EMISSION CONTROL INFORMATION**

ENGINE DISPLACEMENT : 88 cc  
 ENGINE FAMILY : ~~40003~~ 40004  
 PERFORMANCE FAMILY : ~~40003~~ 40004  
 THIS VEHICLE IS CERTIFIED TO OPERATE ON GASOLINE. THIS VEHICLE CONFORMS TO US EPA REGULATIONS OF 25 GPM/HP/CC → 100.000 GPM/HP/CC AND CALIFORNIA REGULATIONS OF 25.0 GPM/HP/CC → 100.000 GPM/HP/CC FOR 2012 MODEL YEAR NEW ATVs. ENGINE EXHAUST CONTROL SYSTEM : ~~1.0E.P00~~

ENGINE TUNEUP SPECIFICATIONS :  
 IGNITION TIMING : ~~NOT ADJUSTABLE~~  
 IDLE SPEED : ~~1700~~ ± 100 RPM IN NEUTRAL  
 IDLE MIXTURE : NOT ADJUSTABLE  
 VALVE CLEARANCE : ~~0.04~~ → 0.03 mm INTAKE & EXHAUST  
 SPARK PLUG : ~~NGK~~ (RT704)  
 SPARK PLUG GAP : ~~0.8~~ → 0.7 mm  
 FUEL : UNLEADED GASOLINE ONLY - ~~87~~ (88 → 90/2) OCTANE  
 OIL : ~~10W-30~~ (SEE THE OWNER'S MANUAL)  
 MANUFACTURED : \*\* / \*\*\*\* (MONTH/YEAR)

KWANG YANG MOTOR CO., LTD. KYMCO USA Inc.  
 TAIWAN Spartanburg, SC 29587 USA



## SAFETY INFORMATION

### IMPORTANT MESSAGE TO PARENTS

**Your child's safety is very important to KYMCO.** That's why we urge you to read this message before you let any young person ride this ATV. Off-road riding can be fun. However, an ATV is not a toy and it can be hazardous to operate. As with any youth activity involving speed and skill-such as bicycling or skateboarding-poor judgement can result in injuries and we don't want that to happen! You can help prevent accidents by making good decisions about if, when, and how your youngster rides this ATV.

#### **Evaluate Riding Readiness**

The first decision you'll need to make is whether your youngster is ready to ride. Riding readiness varies widely from one person to another, and while the minimum age recommended for this ATV is 6 years old, there are other factors that you should consider.



**Physical size and ability** are important considerations. To help determine whether a youngster is big enough for this ATV, have them stand up on the footboards and grasp the handgrips. While the youngster holds this position, check that they have at least three inches (8cm) of clearance between the ATV seat and the youngster's "seat of the pants". A rider needs at least three inches (8cm) of clearance so they can stand up for balance and comfort, and to shift their body forward, backward and from side to side.

Also make sure your youngster can comfortably reach and work all the controls. For example, can they turn the handlebars all the way to the right and left? Can they easily use their feet to work the brake pedal and gearshift lever? Can they operate the throttle and brake levers while they hold onto the handgrips? If not, the youngster is not physically ready to ride this ATV.

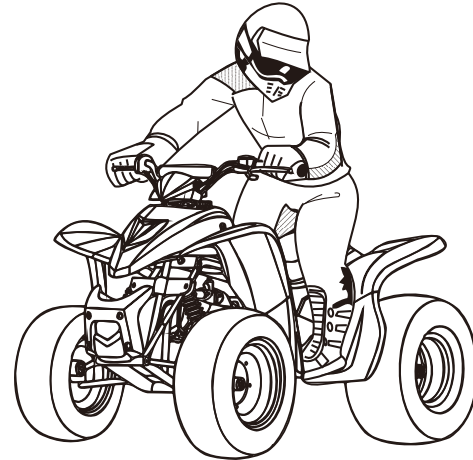

Before you let a youngster ride an ATV, decide whether they are physically, mentally and emotionally ready to ride.

**Athletic ability** is another requirement for riding a ATV. Generally speaking, your youngster should be good at riding a bicycle before they get on an ATV. Can your youngster judge speeds and distances while riding a bicycle and react with proper hand and foot actions? Anyone who does not have good coordination, balance, and agility is not ready for this ATV.

**Mental and emotional maturity** are also necessary for safe riding. Does your youngster think through problems and come to logical solutions? On a bicycle, does your youngster obey safe riding rules? Be honest! Young people who take unnecessary risks, make bad judgments and don't obey rules are not ready to ride this ATV.

If you decide that your youngster is ready to safely operate this ATV, make sure both of you first carefully read and understand the instructions and warnings in this Owner's Manual. Also be sure that your youngster always wears a helmet and other appropriate riding equipment when operating or sitting on the ATV.

### **Patience And Practice**

Even if a youngster takes a certified training course, it's up to you to ensure your youngster's safety. Remember, learning to ride a ATV is a gradual step-by-step process. It takes time, patience and practice.

To help you regulate your youngster's rate of learning, your ATV was delivered with an **adjustable throttle limiter**. We recommend that all beginning riders start off with the throttle limiter adjusted as delivered. The limiter may be adjusted to gradually increase maximum speed as the beginner becomes more familiar with operating the ATV. For adjustment and removal instructions.

### **Always Supervise Young Riders**

Supervision is another important obligation of parents. Even after youngsters have become skilled off-road riders, make sure they always have adult supervision while riding. It also helps to regularly remind young riders to follow the instructions and warnings in this manual. And remember, it's the parent's responsibility to see that the ATV is properly maintained and kept in safe operating condition.

If you choose to lend your ATV, do make sure that any riders under 16 years old will have adult supervision. Your youngster should understand that the decision to lend the ATV is yours.

### **In Summay**

Children differ in skills, physical abilities, and judgement. Some children may not be able to operate an ATV safely. Parents should supervise their child's use of the ATV at all times. Parents should permit continued use only if they determine that the child has the ability to operate the ATV safely.

**Safe and responsible riding** must be an on-going commitment - by you and your youngster. When you both put safety first, you can enjoy more peace of mind, and your youngster can enjoy many hours of safe off-road riding.

## SPECIAL SAFETY MESSAGES

AN ATV IS NOT A TOY AND CAN BE HAZARDOUS TO OPERATE. An ATV handles differently from other vehicles including motorcycles and cars. A collision can occur quickly, even during routine maneuvers such as turning and riding on hills or over obstacles, if you fail to take proper pre-cautions.

SEVERE INJURY OR DEATH can result if you do not follow these instructions:

- Read this manual and all labels carefully and follow the operating procedures described.
- Never operate an ATV without proper training or instruction.  
Beginners should receive training from a certified instructor.
- Always follow the age recommendation:
  - A child under 6 years old should never operate an ATV with engine under 70cc size.
  - A child under 6 years old should never operate this ATV.
- Never allow a child under age 16 to operate an ATV without adult supervision, and never allow continued use of an ATV by a child if he or she does not have the abilities to operate it safely.
- Never carry a passenger on an ATV.
- Never carry cargo or tow a trailer.

## **IMPORTANT NOTICES**

### **READ THIS MANUAL CAREFULLY**

Your Owner's Manual contains important information on safety, operation, and maintenance. Any one who operates this ATV should carefully read and understand the contents of this manual before riding the vehicle.

It is especially important that parents make sure their children fully understand and follow the information and procedures contained in the manual.

### **AGE RECOMMENDATION**

This ATV is intended for use by children at least 6 years old. Never allow children under the age of 6 to operate this ATV.

### **RIDER TRAINING**

Anyone who operates this vehicle should get proper instruction.

### **FOR OFF-ROAD USE ONLY**

This machine is designed and manufactured for OFF-ROAD use only. It is illegal and unsafe to operate this machine on any public street, road or highway.

This machine complies with all applicable OFF-ROAD noise level and spark arrester laws and regulation in effect at the time of manufacture.

Please check your local riding laws and regulations before operating this machine.

## **NOTE TO PARENTS**

Parents should read the "Important Message to Parents" beginning on page 4 and the "Parents & Beginning riders" booklet received with the ATV and then decide whether their youngster is ready to ride.

"Parents, Youngsters and ATVs" focuses on the beginning rider, and discusses how to evaluate your youngster's readiness to ride as well as showing you how to introduce your youngster to ATV riding.

Your ATV was delivered with a speed retractor for new riders.

## SPECIAL MESSAGES

KYMCO provides many important safety messages both in this manual and on the vehicle. For your safety and the safety of others, pay special attention to all warnings preceded by this alert symbol . Failure to follow the warnings contained in this manual can result in SERIOUS INJURY or DEATH.



**Indicates a strong possibility that serious injury or death may result if instructions are not followed.**

To protect your vehicle from damage, pay attention to caution to cautions.

**CAUTION**      **Indicates a possibility that equipment or property damage could result if instructions are not followed.**

**Note:**              Gives helpful information

The Owner's Manual should be considered a permanent part of your ATV. It should remain with the vehicle at all times and stay with the ATV if it is sold.



## PREFACE

Congratulations on your purchase of the KYMCO ATV. KYMCO take pride in a worldwide reputation for quality-in research, design, production and service.

For replacement parts and accessories, we recommend genuine KYMCO products. They've been specially designed for your vehicle and manufactured to meet KYMCO's demanding standards.

This manual will provide you with a good basic understanding of the features and operation of this machine. This manual includes important safety information. It provides information about special techniques and skills necessary to ride your machine. It also includes basic maintenance and inspection procedures. If you have any questions regarding the operation or maintenance of your machine, please consult a KYMCO dealer.

We wish you many years of safe and enjoyable riding.

While reading this manual, remember:



**Indicates a strong possibility that serious injury or death may result if instructions are not followed.**

All information in this publication is based on the latest product information available at the time of approval for printing. KWANG YANG MOTOR CO.,LTD reserves the right to make changes at any time without notice and without incurring any obligation.

## CONTENTS

	Page		Page
LOCATION OF THE WARNING AND SPECIFICATION LABELS.....	1	CONTROL FUNCTIONS.....	21
SAFETY INFORMATION.....	5	Ignition switch.....	21
IMPORTANT MESSAGE TO PARENTS.....	5	Handlebar switches.....	22
Evaluate Riding Readiness.....	5	Engine stop switch.....	22
Always Supervise Young Riders.....	8	Headlight switch.....	23
SPECIAL SAFETY MESSAGES.....	10	Stator button.....	23
DESCRIPTION AND MACHINE		Kick starter.....	24
IDENTIFICATION.....	16	Remote engine stop switch.....	25
Key identification number.....	16	Throttle lever.....	26
Frame and engine serial number.....	17	Speed limiter.....	27
Parts location.....	18	Front brake.....	28
		Rear brake.....	28
		Parking brake.....	29
		Fuel tank cap.....	30
		Fuel valve.....	31
		Seat.....	33
		Flag pole bracket.....	34
		Storage compartment.....	34

(Cont'd)

	Page		Page
PRE-OPERATION CHECKS.....	35	Riding Your ATV.....	50
Front and rear brakes.....	36	GETTING TO KNOW YOUR ATV.....	51
Fuel.....	37	BEFORE RIDING.....	51
Engine oil and Transmission oil.....	39	RIDER PREPARATION.....	51
Chain.....	40	RIDE WITH CARE AND GOOD	
Throttle lever.....	40	JUDGEMENT.....	52
Fittings and fasteners.....	40	Pre-operation checks.....	53
Lights.....	40	Wight limits.....	54
Switches.....	40	Accessories.....	55
Tires.....	41	No Modifications.....	56
How to measure tire pressure.....	42	SAFE RIDING RULES.....	57
Tire wear limit.....	43	BE CAREFUL WHERE YOU RIDE.....	60
OPERATION.....	44	FOR OFF-ROAD USE ONLY.....	62
Starting a cold engine.....	44	Ride Only When Visibility Is Good.....	62
Starting a warm engine.....	46	During operation.....	63
Warming up.....	46	Exhaust system.....	69
Engine break-in.....	46	RIDING.....	70
Parking.....	47	BRAKING.....	72
Parking on a slope.....	48	TURNING YOUR ATV.....	74
Accessories.....	49		

(Cont'd)

	Page		Page
SLIDING AND SKIDDING.....	76	Valve clearance adjustment.....	107
CLIMBING UPHILL.....	78	Idle speed adjustment.....	108
RIDING DOWNHILL.....	84	Throttle lever adjustment.....	109
CROSSING A SLOPE.....	86	Front brake shoe inspection.....	110
RIDING OVER ROUGH TERRAIN.....	88	Rear brake pads inspection.....	110
CROSSING THROUGH SHALLOW		Front brake lever free play adjustment.....	111
WATER.....	89	Brake fluid inspection.....	113
PARKING.....	90	Drive chain slack check.....	115
WHAT TO DO IF.....	91	Drive chain slack adjustment.....	115
WHAT TO DO.....	91	Drive chain cleaning and Lubrication.....	117
		Cable inspection and lubrication.....	117
PERIODIC MAINTENANCE AND		Brake lever lubrication.....	118
ADJUSTMENT.....	93	Knuckle shaft and rear fork shaft	
Tool kit.....	93	Lubrication.....	118
PERIODIC MAINTENANCE/		Wheel removal.....	119
LUBRICATION.....	95	Wheel installation.....	119
Engine oil.....	97	Battery.....	120
Transmission oil.....	101	Fuse replacement.....	122
Spark plug inspection.....	104	Spark arrester cleaning.....	124
Air filter cleaning.....	105	Troubleshooting.....	126
		Troubleshooting chart.....	127

(Cont'd)

	Page
CLEANING AND STORAGE.....	128
A. Cleaning.....	128
B. Storage.....	130
SPECIFICATIONS.....	132
NOISE REGULATION.....	136
MAINTENANCE RECORD.....	137
INDEX.....	138

- Always avoid operating an ATV on any paved surfaces, including sidewalks, driveways, parking lots and streets.
- Never operate an ATV on any public street, road or highway, even a dirt or gravel one.
- Never operate an ATV without wearing an approved motorcycle helmet that fits properly. You should also wear eye protection (goggles or face shield), gloves, boots, long-sleeved shirt or jacket, and long pants.
- Never consume alcohol or drugs before or while operating this ATV.
- Never operate at speeds too fast for your skills or the conditions. Always go at a speed that is proper for the terrain, visibility and operating conditions, and your experience.
- Never attempt wheel, jump, or other stunt.
- Always inspect your ATV each time you use it to make sure it is in safe operating condition. Always follow the inspection and maintenance procedures and schedules described in this manual.
- Always keep both hands on the handlebars and both feet on the footboards of the ATV during operation.
- Always go slowly and be extra careful when operating on unfamiliar terrain. Always be alert to changing terrain conditions when operating the ATV.

- Never operate on excessively rough, slippery or loose terrain until you have learned and practiced the skills necessary to control the ATV on such terrain. Always be especially cautious on these kinds of terrain.
- Always follow proper procedures for turning as described in this manual. Practice turning at low speeds before attempting to turn at faster speeds. Do not turn at excessive speed.
- Never operate the ATV on hills too steep for the ATV or for your abilities. Practice on smaller hills before attempting larger hills.
- Always follow proper procedures for climbing hills as described in this manual. Check the terrain carefully before you start up any hill. Never climb hills with excessively slippery or loose surfaces. Shift your weight forward. Never open the throttle suddenly. Never go over the top of a hill at high speed.
- Always follow proper procedures for going down hills and for braking on hills as described in this manual. Check the terrain carefully before you start down any hill. Shift your weight backward. Never go down a hill at high speed. Avoid going down hill at an angle that would cause the vehicle to lean sharply to one side. Go straight down the hill where possible.
- Always follow proper procedures for crossing the side of a hill as described in this manual. Avoid hills with excessively slippery or loose surfaces. Shift your weight to the uphill side of the ATV. Never attempt to turn the ATV around on any hill until you have mastered the turning technique described in this manual on level ground. Avoid crossing the side of a steep hill if possible.

- Always use proper procedures if you stall or roll backwards when climbing a hill. To avoid stalling, maintain a steady speed when climbing a hill. If you stall or roll backwards, follow the special procedure for braking described in this manual. Dismount on the uphill side or to a side if pointed straight uphill. Turn the ATV around and remount, following the procedure described in this manual.
- Always check for obstacles before operating in a new area. Never attempt to operate over large obstacles, such as large rocks or fallen trees. Always follow proper procedures when operating over obstacles as described in this manual.
- Always be careful when skidding or sliding. Learn to safely control skidding or sliding by practicing at low speeds and on level, smooth terrain. On extremely slippery surfaces, such as ice, go slowly and be very cautious in order to reduce the chance of skidding or sliding out of control.
- Never operate an ATV in fast flowing water or in water deeper than that recommended in this manual. Remember that wet brakes may have reduced stopping ability. Test your brakes after leaving water. If necessary, apply them several times to let friction dry out the linings.
- Always use the size and type tires specified in this manual. Always maintain proper tire pressure as described in this manual.
- Never modify an ATV through improper installation or use of accessories.



 **WARNING**

**POTENTIAL HAZARD**

Improper handling of gasoline.

**WHAT CAN HAPPEN**

Gasoline can catch fire and you could be burned.

**HOW TO AVOID THE HAZARD**

Always turn off the engine when refueling.

Do not refuel right after the engine has been running and is still very hot.

Do not spill gasoline on the engine or exhaust pipe/muffler when refueling.

Never refuel while smoking, or while in the vicinity of sparks, open flames, or other sources of ignition such as the pilot lights of water heaters and clothes dryers.

When transporting the machine in another vehicle, be sure it is kept upright and that the fuel cock is in the "OFF" position.

Otherwise, fuel may leak out of the carburetor or fuel tank.

**WHAT CAN HAPPEN**

Gasoline is poisonous and can cause injuries.

**HOW TO AVOID THE HAZARD**

If you should swallow some gasoline or inhale a lot of gasoline vapor, or get some gasoline in your eyes, see your doctor immediately.

If gasoline spills on your skin, wash with soap and water. If gasoline spills on your clothing, change your clothes.

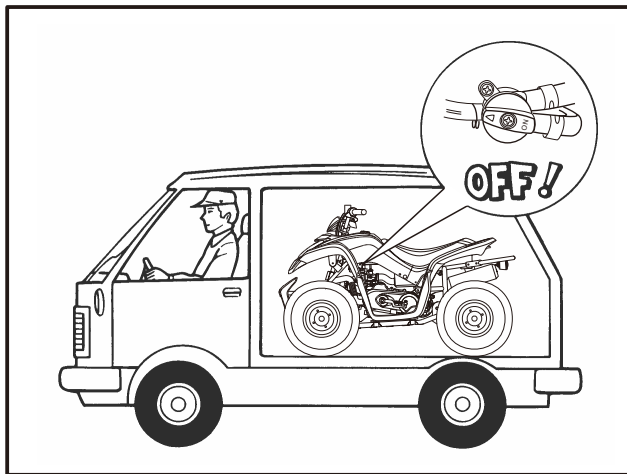

## **⚠ WARNING**

### **POTENTIAL HAZARD**

Starting or running the engine in a closed area.

### **WHAT CAN HAPPEN**

Exhaust fumes are poisonous and may cause loss of consciousness and death within a short time.

### **HOW TO AVOID THE HAZARD**

Always operate your machine in an area with adequate ventilation.

## DESCRIPTION AND MACHINE IDENTIFICATION

### Identification number records

Record the key identification number, frame serial number, engine serial number and model code information for assistance when order replacement parts.

KEY NO. \_\_\_\_\_

FRAME NO. \_\_\_\_\_

ENGINE NO. \_\_\_\_\_

MODEL CODE \_\_\_\_\_

### Key identification number

The key identification number is stamped on the hang tag as shown in the following illustration.



(1) Key identification number

## Frame and engine serial number

The frame serial number is stamped on the front of the frame.

The engine serial number is stamped on the left crankcase.

(1) Frame serial number



(1)



(2) Engine serial number

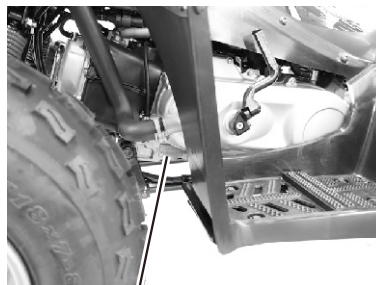

(2)



## Parts location

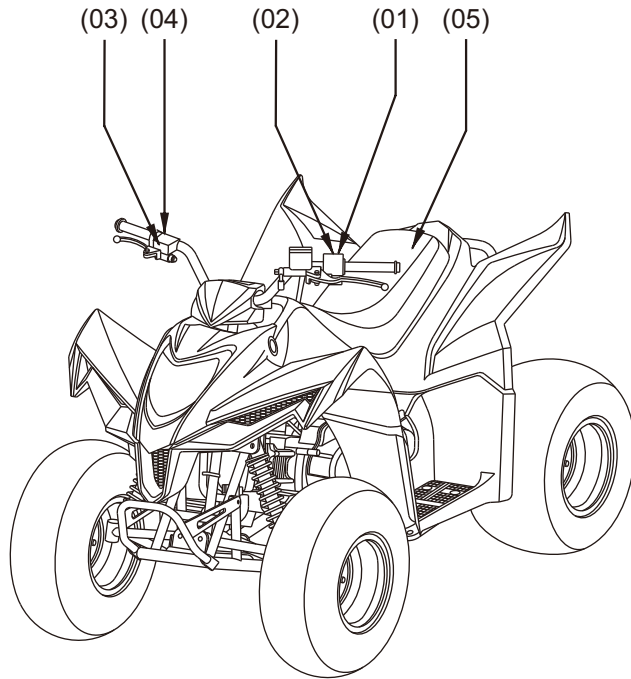

- (1) Handlebar switch
- (2) Ignition switch
- (3) Speed limiter
- (4) Throttle lever
- (5) Seat

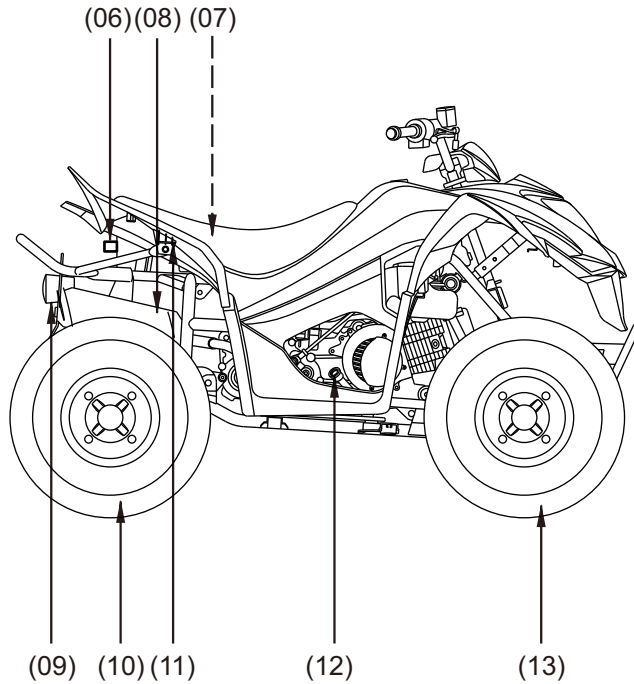

- (06) Remote engine stop switch
- (07) Storage compartment, containing
  - Owner's manual
  - Air pressure gauge
  - Tool kit
- (08) Exhaust pipe
- (09) Taillight/Stop light
- (10) Rear wheel
- (11) Seat lock lever
- (12) Oil filler cap/dipstick
- (13) Front wheel

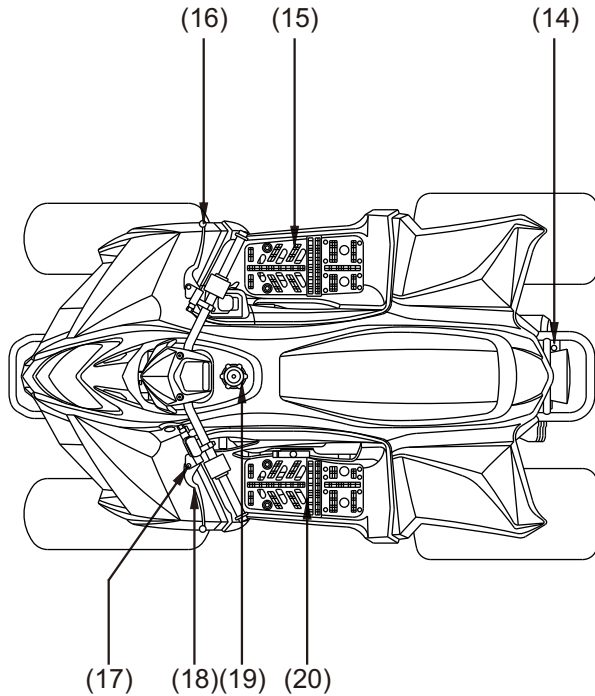

- (14) Flag pole bracket
- (15) Right footboard
- (16) Front brake lever
- (17) Parking brake
- (18) Rear brake lever
- (19) Fuel fill cap
- (20) Left footboard

**NOTE:**

The machine you have purchased may differ slightly from those shown in the figures of this manual.

## CONTROL FUNCTIONS

### Ignition switch

Functions of the respective switch positions are as follows:

OFF:

All electrical circuits are switched off. The key can be removed in this position.

ON (•):

The taillight can be turned on.

With the engine stop switch at run (⊗), the engine can be started.

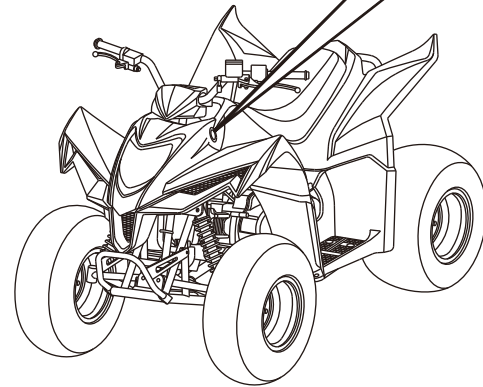
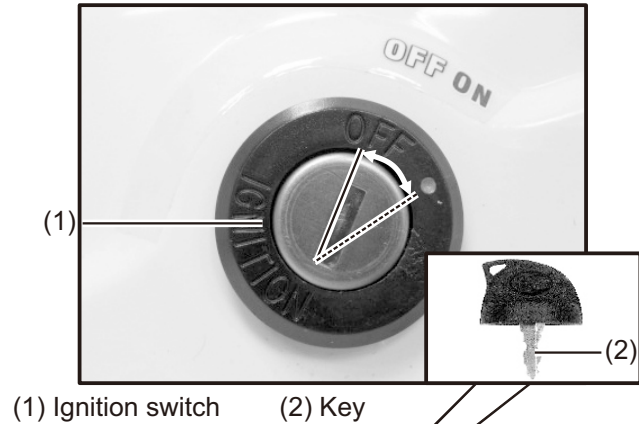

The key cannot be removed.





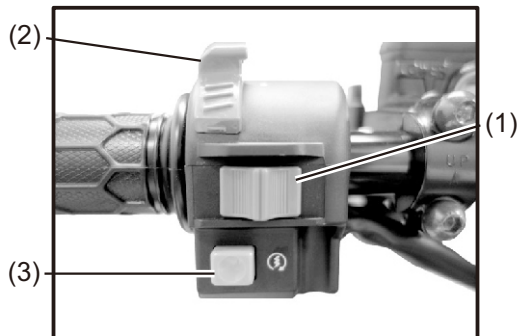

## Handlebar switches



- (1) Engine stop switch "  " & "  "
- (2) Headlight switch (for genuine KYMCO accessories)
- (3) Start switch "  "

## Engine stop switch

When the switch is at the RUN (  ) position, the engine will operate. When the switch is at OFF position, the engine will not operate.

This switch is intended primarily as a safety or emergency control, and it should normally remain at the RUN (  ) position.

## NOTE:

If you stop your ATV by turning the engine stop switch OFF (  ), be sure to turn the ignition switch OFF to prevent battery discharge.

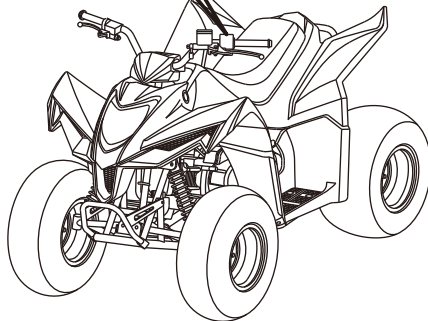

## Headlight switch

The headlight switch should be operated when you add the headlight equipment (using genuine KYMCO accessories).

Turning the switch to the "  " position to switch off the headlight.



Turning the switch to the "  " position to switch on the low beam.

Turning the switch to the "  " position to switch on the high beam.

### NOTE:

- The USA model does not come equipped with headlights as standard equipment.
- If the headlight is not equipped, be sure to turn the headlight switch "  " to prevent battery discharge.



## Starter button

To start the engine, press the starter button, with the ignition switch ON (  ) and the engine stop switch at RUN (  )

### CAUTION:

See starting instructions prior to starting engine.

### NOTE:

If the starter switch is pushed with the ignition switch "  " and the engine stop switch "  ", the starter motor will be activated but the engine will not start. To start the engine, be sure to position the engine stop switch at "  ".



## Kickstarter

The kick starter cranks the engine when the kick starter is operated.

### CAUTION:

See starting instructions prior to starting engine.

### NOTE:

If the kick starter is operated with the ignition switch at " · " and the engine stop switch "  ", the engine will not start. To start the engine, be sure to position the engine stop switch at "  ".

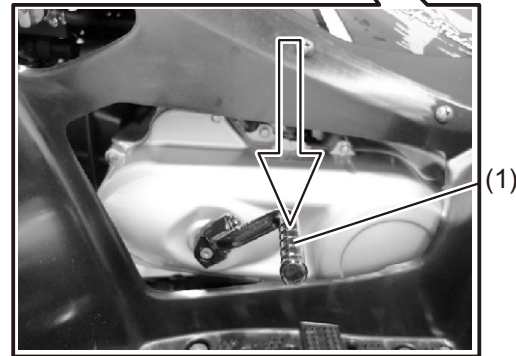
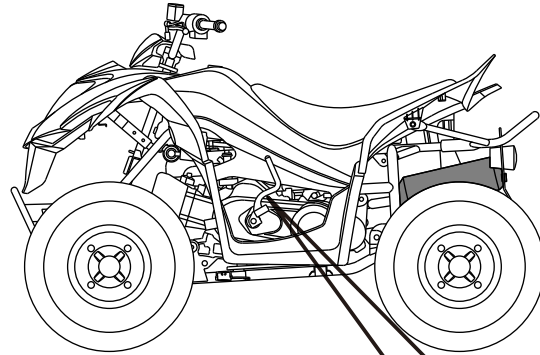

(1) Start kick lever

### Remote engine stop switch

The ATV has a remote engine stop switch. This allows the supervisor to follow close behind and stop the engine by pulling a tethered cord. Practice using it when your youngster first starts riding.

#### NOTE:

Make sure the tethered road lead is installed into the remote engine stop switch. When the tethered road lead is not installed, the engine will not operate.

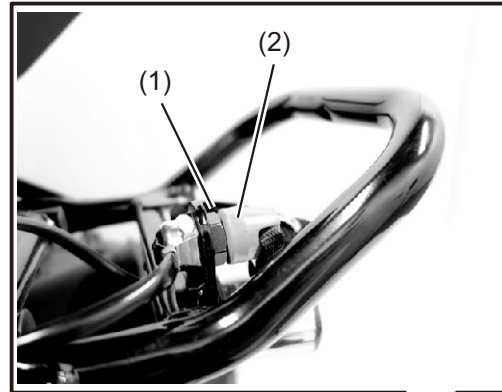

- (1) Remote engine stop switch
- (2) Tethered cord lead

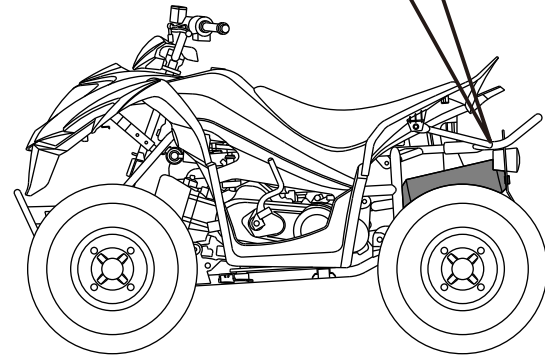

## Throttle lever

It is operated by the thumb. Pressing the lever opens the throttle. When pressure is released, spring tension automatically closes the throttle. Regulate the speed of the machine by varying the throttle position.

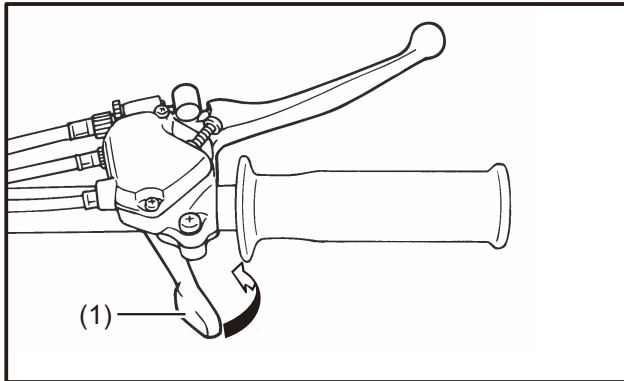

(1) Throttle lever

## WARNING

### POTENTIAL HAZARD

**Malfunction of throttle.**

### WHAT CAN HAPPEN

The throttle could be hard to operate, making it difficult to speed up or slow down when you need to. This could cause an accident.

### HOW TO AVOID THE HAZARD

Check the operation of the throttle lever before you start the engine. If it does not work smoothly, check for the cause.

Correct the problem before riding the ATV.

Consult a KYMCO dealer if you can't find or solve the problem yourself.

## Speed limiter

The speed limiter keeps the throttle from fully opening, even when the throttle lever is pushed to the maximum. Screwing in the adjuster limits the maximum engine power available and decreases the maximum speed of the ATV.

### WARNING

#### POTENTIAL HAZARD

Improper adjustment of the speed limiter and throttle.

#### WHAT CAN HAPPEN

The throttle cable could be damaged. Improper throttle operation could result. You could lose control, have an accident or be injured.

#### HOW TO AVOID THE HAZARD

Do not turn the speed adjuster out more than 9 mm (0.36 in). Always make sure the throttle lever free play is adjusted to 3 ~ 5 mm (0.12 ~ 0.2 in).

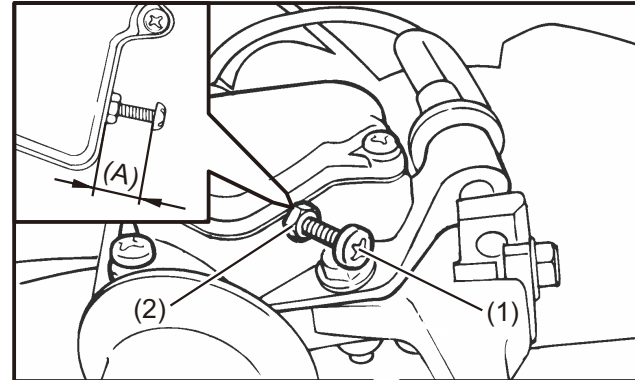

- (1) Adjuster
- (2) Locknut
- (A) 9 mm(0.36 in)

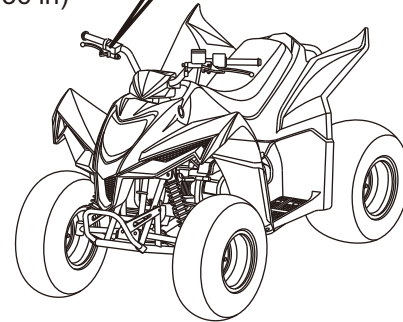

### Front brake

The front brakes are operated by squeezing the front brake lever.

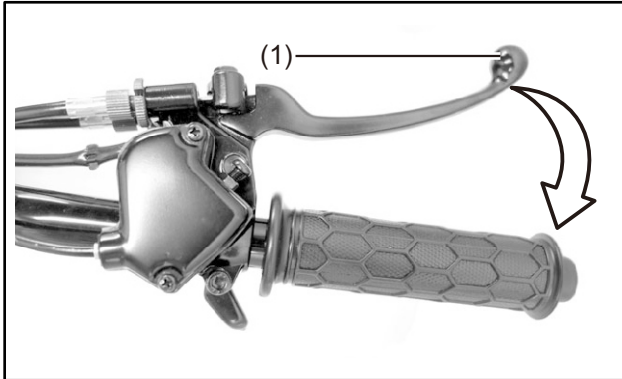

(1) Front brake lever

### Rear brake

The rear brakes are operated by squeezing the rear brake lever.

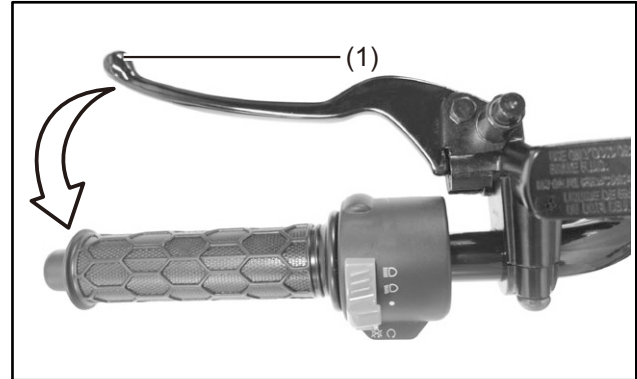

(1) Rear brake lever

## Parking brake

To set the parking brake, squeeze the front brake lever and lock it with the lock pin. Always set the parking brake when parking and before starting the engine.

To unlock the parking brake, squeeze the front brake lever until the lock pin releases.

Using the parking brake in freezing weather may cause the brakes to freeze in the locked position.



(1) Lock pin

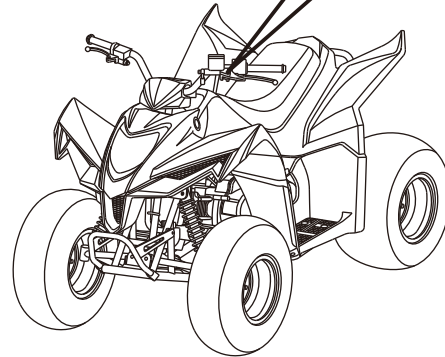



**⚠ WARNING**

**POTENTIAL HAZARD**

Improper use of the parking brake.

**WHAT CAN HAPPEN**

The ATV could start moving unexpectedly if the parking brake is not applied before starting the engine. This could cause loss of control or a collision.

The brake could overheat if you ride the ATV without releasing the parking brake.

You could lose braking performance which could cause an accident. You could also wear out the brakes prematurely.

**HOW TO AVOID THE HAZARD**

Always set the parking brake before starting the engine.

Always be sure you have released the parking brake before you begin to ride.

**Fuel tank cap**

After refueling, be sure to tighten the fuel tank cap.

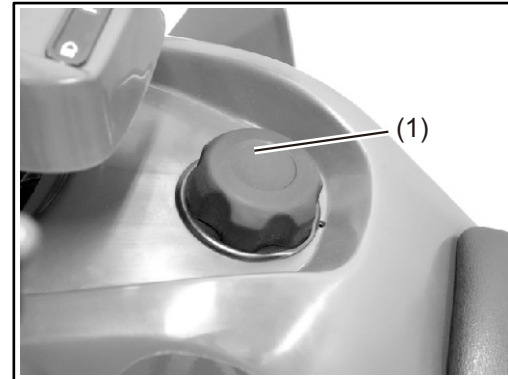

(1) Fuel tank cap

## Fuel valve

The fuel valve supplies fuel from the fuel tank to the carburetor.

The fuel valve has three positions.

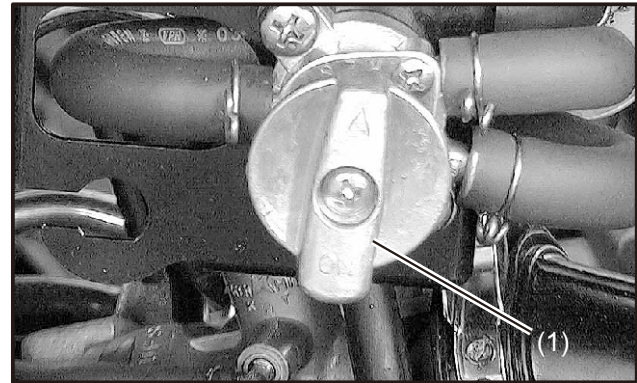

(1) Fuel lever

OFF :With the lever and " Δ " mark in this position fuel will not flow. Always turn the lever to this position when the engine is not running.

ON : With the lever " Δ " mark in this position, fuel flows to the carburetor. Normal riding is done with the lever in this position.

RES :This indicates reserve. If you run out of fuel while riding, turn the lever " Δ " mark to this position. THEN FILL THE FUEL TANK AT THE FIRST OPPORTUNITY. After refueling, return the fuel valve lever to the "ON" position.

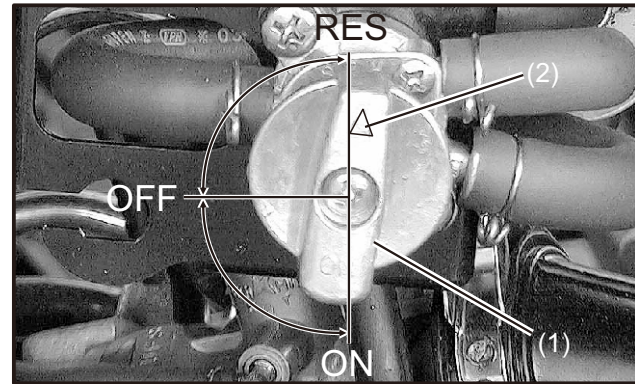

(1) Fuel lever      (2) " Δ " mark

**NOTE:**

After refueling, do not operate the ATV with the fuel valve in the RES position. If you run out of fuel, there will be no reserve supply.

## Seat

To remove the seat, pull upward the seat lock lever and pull up the seat at the rear.

To install the seat, align the tabs on the seat with the grommets on the frame and press the seat down until it locks.

(1) Seat lock lever

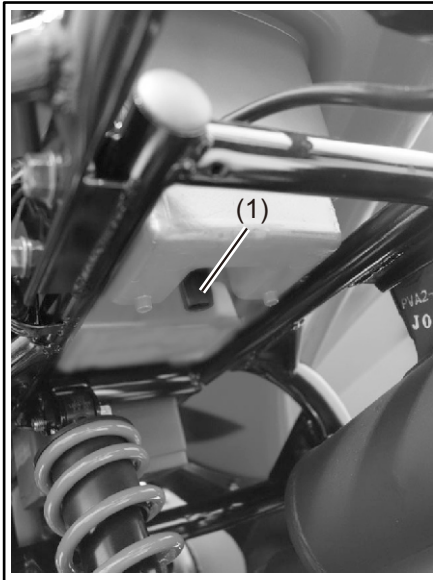

### NOTE:

Make sure that the seat is securely fitted.

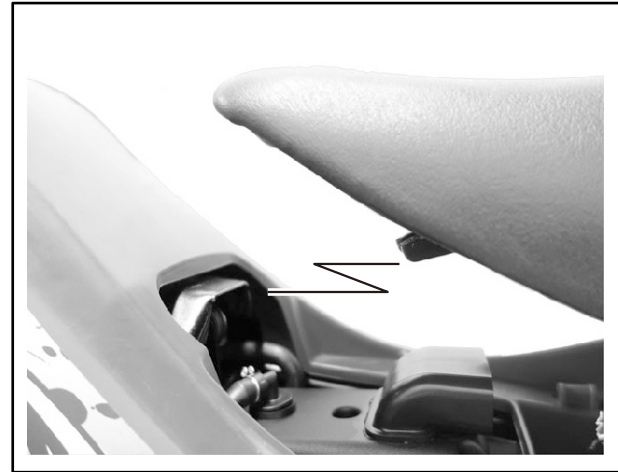

## Flag pole bracket

To mount a flag pole in the bracket.

### NOTE:

Flag poles are required in some riding areas. Check local regulations before riding.



(1) Flag pole bracket

## Storage compartment

The storage compartment is located under the seat.

Be careful not to flood this area when washing your ATV or riding through water, and never put any electric conduction material in the storage compartment.



## PRE-OPERATION CHECKS

Before using this machine, check the following points:

ITEM	ROUTINE	PAGE
<b>Brake</b>	<ul style="list-style-type: none"> <li>• Check operation, condition, free play (drum brake) and brake fluid level (disk brake).</li> <li>• Adjust (drum brake) if necessary.</li> <li>• Fill with DOT 4 brake fluid (disk brake) if necessary.</li> </ul>	36~37, 110~114
<b>Fuel</b>	<ul style="list-style-type: none"> <li>• Check fuel level.</li> <li>• Fill with fuel if necessary.</li> </ul>	37~38
<b>Engine oil and Transmission oil</b>	<ul style="list-style-type: none"> <li>• Check oil level.</li> <li>• Fill with oil if necessary.</li> </ul>	39, 97~103
<b>Drive chain</b>	<ul style="list-style-type: none"> <li>• Check chain slack and condition.</li> <li>• Adjust if necessary.</li> </ul>	40, 115~117
<b>Throttle</b>	<ul style="list-style-type: none"> <li>• Check for proper throttle cable operation.</li> </ul>	40
<b>Wheels and tires</b>	<ul style="list-style-type: none"> <li>• Check tire pressure, wear and damage.</li> </ul>	41~43, 119
<b>Fittings and fasteners</b>	<ul style="list-style-type: none"> <li>• Check all fitting and fasteners.</li> </ul>	40
<b>Switches</b>	<ul style="list-style-type: none"> <li>• Check for proper function.</li> </ul>	40
<b>Lights</b>	<ul style="list-style-type: none"> <li>• Check for proper operation.</li> </ul>	40



## **WARNING**

### **POTENTIAL HAZARD**

**Failure to inspect the ATV before operating.**

**Failure to properly maintain the ATV.**

### **WHAT CAN HAPPEN**

**Increases the possibility of an accident or equipment damage.**

### **HOW TO AVOID THE HAZARD**

**Always inspect your ATV each time you use it to make sure the ATV is in safe operating condition.**

**Always follow the inspection and maintenance procedures and schedules described in the Owner's Manual.**

## **Front and rear brakes**

### **1. Drum brake**

Check for correct free play in the brake levers. If the free play is incorrect, adjust it.

Check operation of the levers. They should move smoothly and there should be a firm feeling when the brake is applied. If not, have the machine inspected by a KYMCO dealer.

### **2. Disk brake**

Make sure there is no brake fluid leakage.

Check operation of the levers. They should move smoothly and there should be a firm feeling when the brake is applied. If not, have the machine inspected by a KYMCO dealer.

### **3. Brake operation**

Test the brakes at slow speed after starting out to make sure they are working properly. If the brakes do not provide proper braking performance, inspect the brakes for wear.

**⚠ WARNING**

**POTENTIAL HAZARD**

**Riding with improperly operating brakes.**

**WHAT CAN HAPPEN**

**You could lose braking ability, which could lead to an accident.**

**HOW TO AVOID THE HAZARD**

**Always check the brakes at the start of every ride. Do not ride the ATV if you find any problem with the brakes. If a problem cannot be corrected by the adjustment procedures provided in this manual, have the ATV inspected by a KYMCO dealer.**

**Fuel**

Fill the fuel tank when necessary and make sure there is sufficient gasoline in the tank.

Check for leaks.

Fuel level should be below the filler neck.

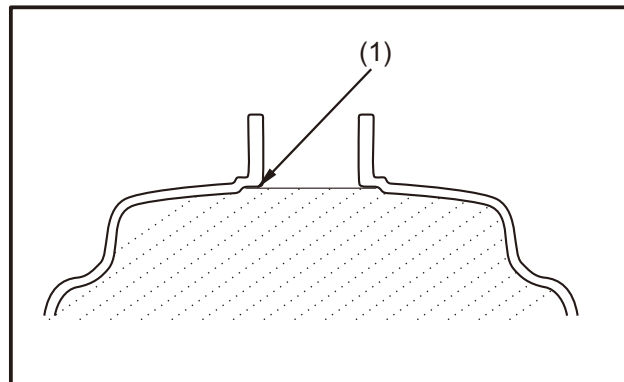

(1) Filler neck

Recommended fuel:

**UNLEADED FUEL**

Fuel tank capacity:

Total: 5.3L(1.11 Imp gal, 1.38 US gal)

Reserve: 1.2L(0.25 Imp gal, 0.31 US gal)



Your KYMCO engine has been designed to use regular unleaded gasoline with a pump octane number of 86 or higher, or research octane number of 91 or higher. If knocking or pinging occurs, use a different brand of gasoline or premium unleaded fuel. Unleaded fuel will give you longer spark plug life and reduced maintenance cost.

Use unleaded fuel only because it produces fewer engine and spark plug deposits and extends the life of the exhaust system. Never use stale or contaminated gasoline or an oil/gasoline mixture. Avoid getting dirt, dust or water in the fuel tank.

 **WARNING**

**POTENTIAL HAZARD**

**Improper care when refueling.**

**WHAT CAN HAPPEN**

**Fuel can spill, which can cause a fire and severe injury.**

**Fuel expands when it heats up. If the fuel tank is overfilled, fuel could spill out due to heat from the engine.**

**HOW TO AVOID THE HAZARD**

**Do not overfill the fuel tank. Be careful not to spill fuel, especially on the engine or exhaust pipe. Wipe up any spilled fuel immediately. Be sure the fuel tank cap is closed securely.**

**Do not refuel right after the engine has been running and is still very hot.**

## Engine and transmission oil

Make sure the engine and transmission oil at the specified level. Add oil as necessary.

Check for leaks.

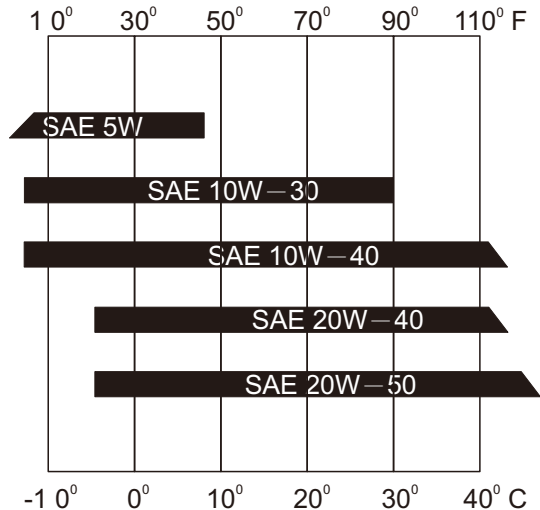

Recommended engine/transmission oil classification: API Service SG type or higher

## CAUTION:

Be sure to use motor oils that do not contain anti-friction modifiers. Passenger car motor oils (often labeled "Energy Conserving") contain anti-friction additives which will cause starter clutch slippage, resulting in reduced component life and poor engine performance.

Engine oil:

Periodic oil change:

0.7 L (0.62 Imp qt, 0.74 US qt)

Total amount:

0.8 L (0.7 Imp qt, 0.84 US qt)

Transmission oil:

Periodic oil change:

0.10 L (0.09 Imp qt, 0.11 US qt)

Total amount:

0.11 L (0.10 Imp qt, 0.12 US qt)

**Chain**

Check the general condition of the chain and check the chain slack before every ride.  
Lubricate and adjust the chain as necessary.

**Throttle lever**

Check to see that the throttle lever operates correctly. It must open smoothly and spring back to idle position when released. Repair as necessary for proper operation.

**Fittings and fasteners**

Always check the tightness of chassis fittings and fasteners before a ride. Take the machine to a KYMCO dealer or refer to the Service Manual for correct tightening torque.

**Lights**

Check the headlight and taillight to make sure they are in working condition. Repair as necessary for proper operation.

**Switches**

Check the operation of the headlight switch, engine stop switch and any other switches.  
Repair as necessary for proper operation.

## Tires



### WARNING

#### POTENTIAL HAZARD

Operating this ATV with improper tires, or with improper or uneven tire pressure.

#### WHAT CAN HAPPEN

Use of improper tires on this ATV, or operation of this ATV with improper or uneven tire pressure, may cause loss of control, increasing your risk of accident.

#### HOW TO AVOID THE HAZARD

1. The tires listed below have been approved by Kwang Yang Motor Co., Ltd. for this model. Other tire combinations are not recommended.

	Size	Type
Front	16*8-7	TUBELESS
Rear	16*8-7	TUBELESS

2. The tires should be set to the recommended pressure:

- Recommended tire pressure

Front: 25 kpa (0.25 kgf/cm<sup>2</sup>, 3.6 psi)

Rear: 25 kpa (0.25 kgf/cm<sup>2</sup>, 3.6 psi)

- Check and adjust tire pressures when the tires are cold.
- Tire pressures must be equal on both sides.

3. Tire pressure below the minimum specified could cause the tire to dislodge from the rim under severe riding conditions.

The following are minimums:

Front: 22 kpa (0.22 kgf/cm<sup>2</sup>, 3.2 psi)

Rear: 22 kpa (0.22 kgf/cm<sup>2</sup>, 3.2 psi)

**4. Never set tire pressure over the recommended**

**Front: 28 kpa (0.28 kgf/cm<sup>2</sup>, 40 psi)**

**Rear: 28 kpa (0.28 kgf/cm<sup>2</sup>, 40 psi)**

**Higher pressures may cause the tire to burst. Inflate the tires very slowly and carefully. Fast inflation could cause the tire to burst.**

#### **How to measure tire pressure**

Use the low-pressure tire gauge.

#### **NOTE:**

The low-pressure tire gauge is included as standard equipment. Make two measurements of the tire pressure and use the second reading. Dust or dirt in the gauge could cause the first reading to be incorrect.

Set pressure tires cold.

Set tire pressures to the following

	Recommended pressure	Minimum	Maximum
Front	25 kpa (0.25 kgf/cm <sup>2</sup> , 3.6 psi)	22 kpa (0.22 kgf/cm <sup>2</sup> , 3.2 psi)	28 kpa (0.28 kgf/cm <sup>2</sup> , 4.0 psi)
Rear	25 kpa (0.25 kgf/cm <sup>2</sup> , 3.6 psi)	22 kpa (0.22 kgf/cm <sup>2</sup> , 3.2 psi)	28 kpa (0.28 kgf/cm <sup>2</sup> , 4.0 psi)

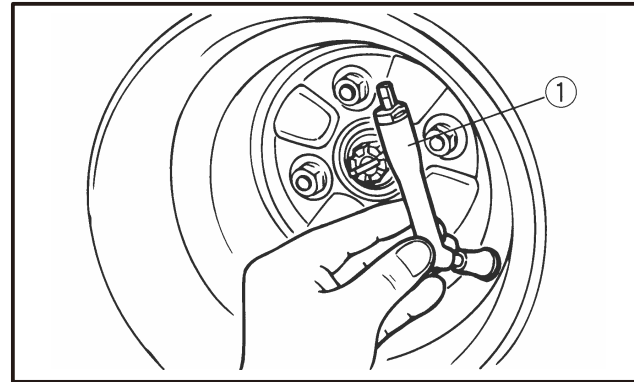

(1) Low-pressure tire gauge

**Tire wear limit**

When the tire groove decreases to 4 mm (0.16 in) due to wear, replace the tire.

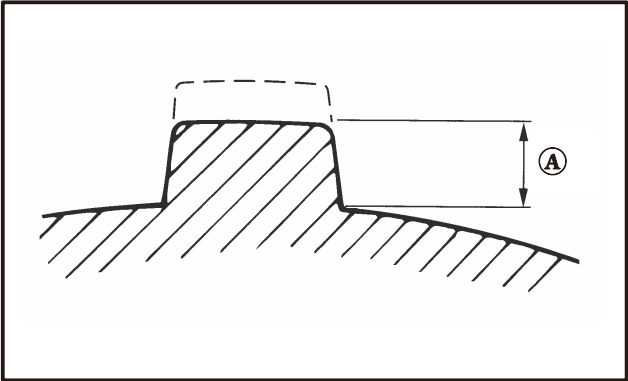

A. 3mm (0.12 in)

## OPERATION



### WARNING

#### POTENTIAL HAZARD

Operating ATV without being familiar with all controls.

#### WHAT CAN HAPPEN

Loss of control, which could cause an accident or injury.

#### HOW TO AVOID THE HAZARD

Read the Owner's Manual carefully. If there is a control or function you do not understand, ask your KYMCO dealer.

## Starting a cold engine



### WARNING

#### POTENTIAL HAZARD

Freezing control cables in cold weather.

#### WHAT CAN HAPPEN

You could be unable to control the ATV, which could lead to an accident or collision.

#### HOW TO AVOID THE HAZARD

When riding in cold weather, always make sure all control cables work smoothly before you begin riding.

1. Select a level surface and lock the parking brake before starting the engine.
2. Turn the fuel lock to "ON".
3. Turn the main switch to " · " and the engine stop switch to " Ⓞ ".
4. Make sure the tethered road lead is installed into the remote engine stop switch.

5. With the throttle closed, push the starter button. Release the starter button as soon as the engine starts.

**NOTE:**

Do not use the electric starter for more than 5 seconds at a time. Release the starter button for approximately 10 seconds before pressing it again.

**CAUTION:**

See the "engine break-in section prior to operating engine for the first time.



**To start the engine without the electric starter:**

1. Follow steps 1 through 4.
2. With the throttle closed, operate the kick starter with a rapid, continuous motion.

**CAUTION:**

- Do not allow the kick starter to snap back freely against the pedal stop as engine case damage could result.
- Raise the kick starter pedal after the kick starter lever is returned to the stop.

**STARTING A WARM ENGINE**

To start a warm engine, refer to the "Starting a cold engine" section. The throttle should be opened slightly.

**Warming up**

To get maximum engine life, always warm up the engine before starting off. Never accelerate hard with a cold engine! To see whether or not the engine is warm.

**CAUTION:**

- Do not operate the throttle (open and close rapidly) as the ATV will move forward suddenly, causing possible loss of control.
- Do not leave the ATV unattended while the engine is warming up.

**Engine break-in**

There is never a more important period in the life of your machine than the period between zero and 20 hours.

For this reason, we ask that you carefully read the following material. Because the engine is brand new, you must not put an excessive load on it for the first 20 hours, the various parts in the engine wear and polish themselves to the correct operating clearances.

During this period, prolonged full throttle operation or any condition which might result in excessive engine heating must be avoided. However, momentary (2~3 seconds maximum) full throttle operation under load does not harm the engine.

Each full throttle acceleration sequence should be followed with a substantial rest period for the engine by cruising at lower r/min so the engine can rid itself of the temporary build up of heat.

If any abnormality is noticed during this period, consult a KYMCO dealer.

1. 0~10 hours:

Avoid continuous operation above half throttle. Allow a cooling off period of five to ten minutes after every hour of operation. Vary the speed of the machine from time to time. Do not operate it at full throttle position.

2. 10~20 hours:

Avoid prolonged operation above 3/4 throttle. Rev the machine freely through the gears but do not use full throttle at any time.

3. After break-in

Avoid prolonged full throttle operation. Vary speeds occasionally.

## Parking

When parking, stop the engine. Turn the fuel lock to "OFF" and apply the parking brake.

Make sure the lock pin into the locked position.

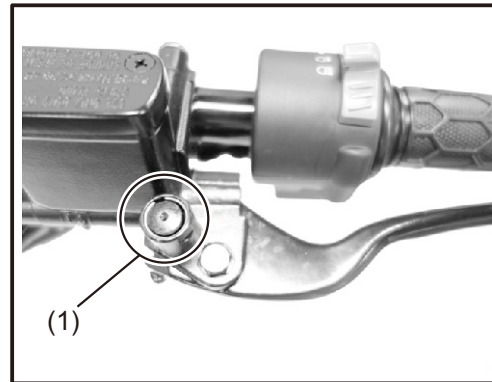

(1) Locked position

## Parking on a slope



### **WARNING**

#### **POTENTIAL HAZARD**

**Parking on a hill or other incline.**

#### **WHAT CAN HAPPEN**

The ATV could roll out of control, increasing the chance of an accident.

#### **HOW TO AVOID THE HAZARD**

Avoid parking on hills or other inclines. If you must park on an incline, place the machine transversely across the incline, apply the parking brake, and block the front and rear wheels with rocks or other objects.

Do not park the ATV at all on hills that are so steep you could not walk up them easily.

1. Bring the machine to a stop by applying the brakes.
2. Stop the engine.
3. With the rear brake applied, apply the parking brake.

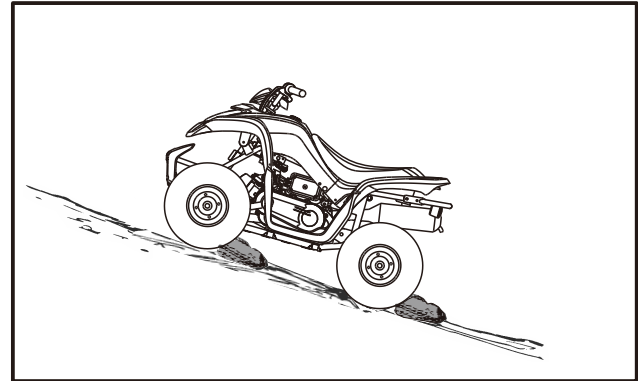

## Accessories

Accessories can affect the handling and control of your ATV. Keep the following in mind when considering an accessory or operating an ATV which has accessories.

- Choose only accessories designed for your ATV. Your KYMCO dealer has a variety of genuine KYMCO accessories. Other accessories may also be available on the market. However, it is not possible for KYMCO to test all non-KYMCO accessories, nor have any control over the quality or suitability of them. Choose a genuine KYMCO accessory, or one that is equivalent in design and quality.
- Accessories should be rigidly and securely mounted. An accessory which can shift position or come off while you are riding could affect your ability to control the ATV.
- Do not mount an accessory where it could interfere with your ability to control the ATV. Examples include (but are not limited to) a heavy or bulky object attached to the handlebars which could make steering difficult, an accessory that limits your ability to move around on the seat, or one that limits your view.
- Use extra caution when riding an ATV with accessories. The ATV may handle differently than it does without accessories.

## Riding Your ATV

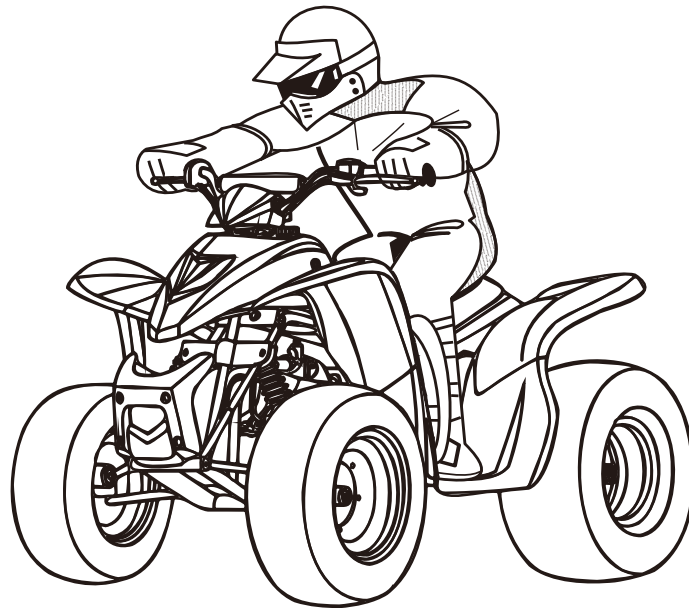

## GETTING TO KNOW YOUR ATV

This ATV is for recreation use. This section, riding your ATV, provides general ATV riding instructions for recreational riding. The skills and techniques described in this section, however, are appropriate for all types of riding. Riding your ATV requires special skills acquired through practice over a period of time. Take the time to learn the basic techniques well before attempting more difficult maneuvers.

Riding your new ATV can be a very enjoyable activity, providing you with hours of pleasure. But it is essential to familiarize yourself with the operation of the ATV to achieve the skill necessary to enjoy riding safely. Before you begin to ride, be sure you have read this Owner's Manual completely and understand the operation of the controls. Pay particular attention to the safety information and special safety message. Please also read all caution and warning labels on your ATV.

## BEFORE RIDING

Before allowing your youngster to ride the ATV, read "Important Message To Parents" carefully and decide whether your youngster is ready to ride.

You need to be prepared before riding. This includes getting proper instruction, making sure your ATV is in good operating condition, and learning some basic safe-riding rules.

## RIDER PREPARATION

### Age Recommendation

For safety, never let children under 6 years old operate this vehicle. Children under 16 should be supervised by an adult.

### WARNING

#### POTENTIAL HAZARD

**Failure to follow the age recommendations for this ATV.**

**Failure to supervise children under 16 on ATV models intended for their use.**

### WHAT CAN HAPPEN

If children use ATVs that are not recommended for their age, severe injury or death can result.

Even though a child may be within the age group for which an ATV is recommended, he or she may not have the skills, abilities, or judgment needed to operate the ATV safely and may be involved in a serious accident.

### HOW TO AVOID THE HAZARD

A child under 6 should never operate this ATV.

Never allow a child under 16 to operate an ATV without adult supervision and never allow continued use of the ATV by a child if he or she does not have the abilities to operate it safely.



### RIDE WITH CARE AND GOOD JUDGEMENT

#### Get training if you are inexperienced.

Beginners should get training from a certified instructor.

Become familiar with this ATV at slow speeds first, even if you are an experienced operator.

Do not attempt to operate at maximum performance until you are totally familiar with the machine's handling and performance characteristics.

### WARNING

#### POTENTIAL HAZARD

Operating this ATV without proper instruction.

#### WHAT CAN HAPPEN

The risk of an accident is greatly increased if the operator does not know how to operate the ATV properly in different situations and on different types of terrain.

### **HOW TO AVOID THE HAZARD**

**Become familiar with this ATV at slow speeds first, even if you are an experienced operator.**

**Do not attempt to operate at maximum performance until you are totally familiar with the machine's handling and performance characteristics.**

**Riding your machine requires skills acquired through practice over a period of time.**

Take the time to learn the basic techniques well before attempting more difficult maneuvers.

### **Pre-operation checks**

Always perform the pro-operation checks listed before riding for safety and proper care of the machine.

## **WARNING**

### **POTENTIAL HAZARD**

**Failure to inspect the ATV before operating.  
Failure to properly maintain the ATV.**

### **WHAT CAN HAPPEN**

**Increases the possibility of an accident or equipment damage.**

### **HOW TO AVOID THE HAZARD**

**Always inspect your ATV each time you use it to make sure the ATV is in safe operating condition.**

**Always follow the inspection and maintenance procedures and schedules described in the Owner's Manual.**



 **WARNING**

**POTENTIAL HAZARD**

**Operating this ATV with improper tires, or with improper or uneven tire pressure.**

**WHAT CAN HAPPEN**

**Use of improper tires on this ATV, or operation of this ATV with improper or uneven tire pressure, may cause loss of control, increasing your risk of an accident.**

**HOW TO AVOID THE HAZARD**

**Always use the size and type tires specified in the Owner's Manual for this vehicle.**

**Always maintain proper tire pressure as described in the Owner's Manual.**

**Weight Limits**

This ATV is not designed to carry cargo or tow a trailer. Do not add a cargo rack or a trailer hitch.

There are limits to how much weight can be carried on your ATV. The following weight limit applies to standard equipment only. Modifying your ATV, using non-standard equipment or riding on terrain that is not flat and smooth could further reduce these limits.

**Maximum weight capacity: 85 kg (187 lb)**

(Including weight of operator, cargo and accessories)

 **WARNING**

**POTENTIAL HAZARD**

**Overloading this ATV or carrying or towing cargo.**

**WHAT CAN HAPPEN**

**Could cause changes in vehicle handling, stability and braking which could lead to an accident.**

**HOW TO AVOID THE HAZARD**

**Never exceed the stated maximum weight capacity for this ATV.**

**Never carry cargo or tow a trailer.**

**Accessories**

Genuine KYMCO accessories have been specifically designed for and tested on this vehicle. Because KYMCO cannot test all other accessories, you are personally responsible for properly selecting, installing, and using non-KYMCO accessories. Always follow the loading instructions above, plus the following:

1. Carefully inspect the accessory to make sure it does not block any lights, reduce ground clearance, or limit suspension travel, steering travel, or other controls.
2. Make sure the accessory does not interfere with your ability to shift body position on the seat or operate hand and foot controls.
3. Do not add electrical equipment that will exceed the vehicle's electrical system capacity. A blown fuse could cause a loss of lights or engine power.



## **WARNING**

### **POTENTIAL HAZARD**

**Operating this ATV with improper modifications.**

### **WHAT CAN HAPPEN**

**Improper installation of accessories or modification of this vehicle may cause changes in handling which in some situations could lead to an accident.**

### **HOW TO AVOID THE HAZARD**

**Never modify this ATV through improper installation or use of accessories. All parts and accessories added to this vehicle should be genuine KYMCO or equivalent components designed for use on this ATV and should be installed and used according to instruction. If you have question, consult an authorized ATV dealer.**

### **No Modifications**

Modifying this ATV or removing original equipment may render the vehicle unsafe or illegal. Spark arresters and mufflers are required in most areas. Don't modify your exhaust system or emission control system components. Remember, excessive noise bothers everyone and creates a bad image for off-road vehicles.

## SAFE RIDING RULES

Please note that the safe Riding Rules apply to all ATV riders.

Even if you are an experienced rider, or after you become one continue to follow these guidelines for your own safety and enjoyment.

### Protective Apparel

Always wear an approved motorcycle helmet when riding your ATV. You should also always wear goggles or a face shield, gloves, boots, a long-sleeved shirt or jacket, and long pants.

**⚠ WARNING**

**POTENTIAL HAZARD**

**Operating this ATV without wearing an approved motorcycle helmet, eye protection and protective clothing.**

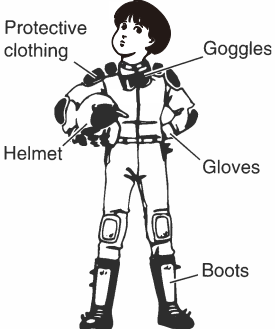

Labels in the illustration:  
Protective clothing  
Goggles  
Helmet  
Gloves  
Boots

## WHAT CAN HAPPEN

**Operating without an approved motorcycle helmet increases your chances of a severe head injury or death in the event of an accident.**

**Operating without eye protection can result in an accident and increases your chances of a severe injury in the event of an accident.**

**Operating without protective clothing increases your chances of severe injury in the event of an accident.**

## HOW TO AVOID THE HAZARD

**Always wear an approved motorcycle helmet that fits properly.**

**You should also wear:**

**eye protection (goggles or face shield)**

**Gloves**

**boots**

**long-sleeved shirt or jacket**

**Long pants**

**Do not operate after consuming alcohol or drugs.**

Operator's performance capability is reduced by the influence of alcohol or drugs.



**⚠ WARNING**

**POTENTIAL HAZARD**

**Operating this ATV after consuming alcohol or drugs.**

**WHAT CAN HAPPEN**

- Could seriously affect your judgment.**
- Could cause you to react more slowly.**
- Could affect your balance and perception.**
- Could result in an accident.**

**HOW TO AVOID THE HAZARD**

**Never consume alcohol or drugs before or while driving this ATV.**

This machine is designed to carry operator only-passengers prohibited.

**▲ WARNING**

**POTENTIAL HAZARD**

Carrying a passenger on this ATV.

**WHAT CAN HAPPEN**

Greatly reduces your ability to balance and control this ATV. Could cause an accident, resulting in harm to you and/or your passenger.

**HOW TO AVOID THE HAZARD**

Never carry a passenger. The long seat is to allow the operator to shift position as needed during operation. It is not for carrying passengers.



## **BE CAREFUL WHERE YOU RIDE**

This machine is designed for off-road use only. Riding on paved surfaces can cause loss of control.

### **⚠ WARNING**

#### **POTENTIAL HAZARD**

**Operating this ATV on paved surfaces.**

#### **WHAT CAN HAPPEN**

**ATV are designed for off-road use only. Paved surfaces may seriously affect handling and control of the ATV, and may cause the vehicle to go out of control.**

#### **HOW TO AVOID THE HAZARD**

**Always avoid paved surfaces, including sidewalks, driveways, parking lots and streets.**

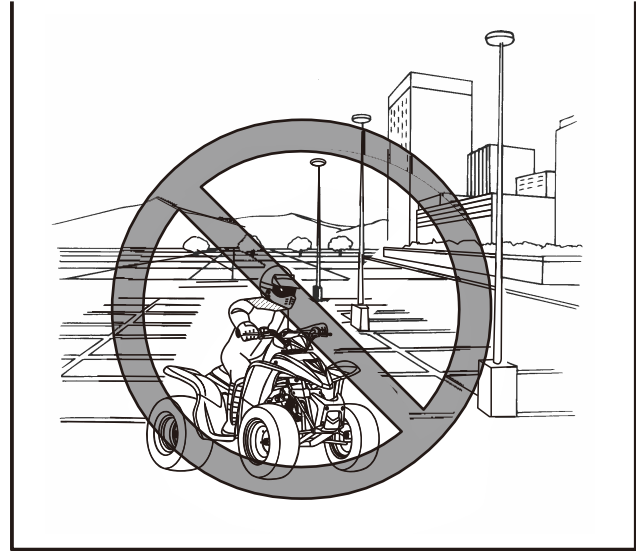

Do not ride on any public road, street, or highway.  
Riding on public roads can result in collisions with other vehicles.

**⚠ WARNING**

**POTENTIAL HAZARD**

**Operating this ATV on public streets, roads or highways.**

**WHAT CAN HAPPEN**

**You can collide with another vehicle.**

**HOW TO AVOID THE HAZARD**

**Never operate this ATV on any public street, road or highway, even a dirt or gravel one.**

**In many states it is illegal to operate ATVs on public streets, roads and highways.**

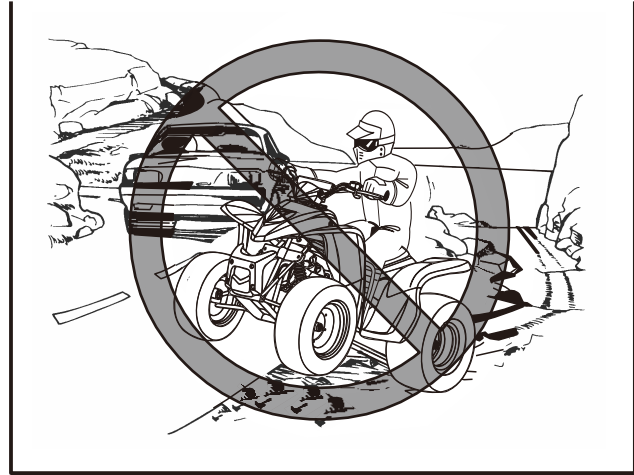



## **FOR OFF-ROAD USE ONLY**

This vehicle is designed and manufactured for off-road use only.

Do not ride in areas posted "no trespassing". Do not ride on private property without getting permission.

## **Ride Only When Visibility Is Good**

Your ATV is not equipped with headlight. It is intended to be used only during the daytime. You should ride only when visibility is good. Plan to stop riding well before it gets dark. Operation at night without lights may be illegal in some states.

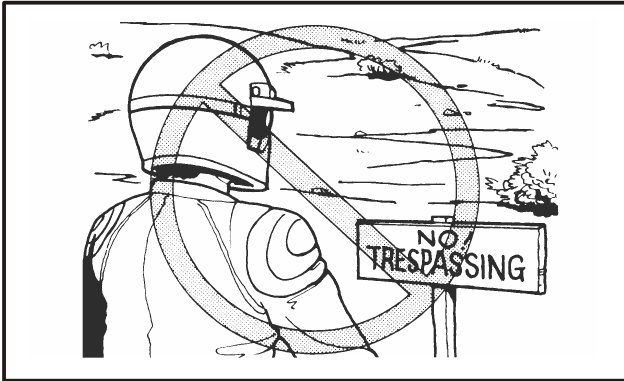

### **During operation**

Always keep your feet on the footboards during operation. Otherwise your feet may contact the rear wheels.

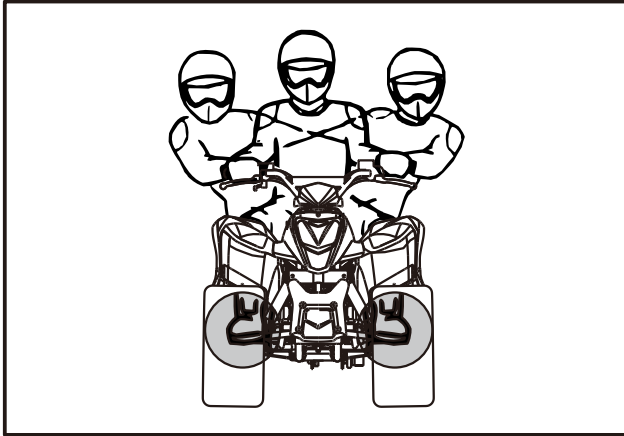

### **⚠ WARNING**

#### **POTENTIAL HAZARD**

**Removing hands from handlebars or feet from footboards during operation.**

#### **WHAT CAN HAPPEN**

Removing even one hand or foot can reduce your ability to control the ATV or could cause you to lose your balance and fall a footboard, your foot or leg may come into contact with the rear wheels, which could injure you or cause an accident.

#### **HOW TO AVOID THE HAZARD**

Always keep both hands on the handlebars and both feet on the footboards of your ATV during operation.

**Do not operate at speeds too fast your skills or the conditions.**

**⚠ WARNING**

**POTENTIAL HAZARD**

**Operating this ATV at speeds too fast for your skills or the conditions.**

**WHAT CAN HAPPEN**

**Increases your chances of losing control of the ATV, which can result in an accident.**

**HOW TO AVOID THE HAZARD**

**Always go at a speed that is proper for the terrain, visibility and operating conditions, and your experience.**

**Speed limiter**

For riders inexperienced with this model, this model is equipped with a speed limiter in the throttle lever housing. The speed limiter limits the power and top speed of the machine.

Turning the screw in decreases top speed, and turning it out increases top speed.

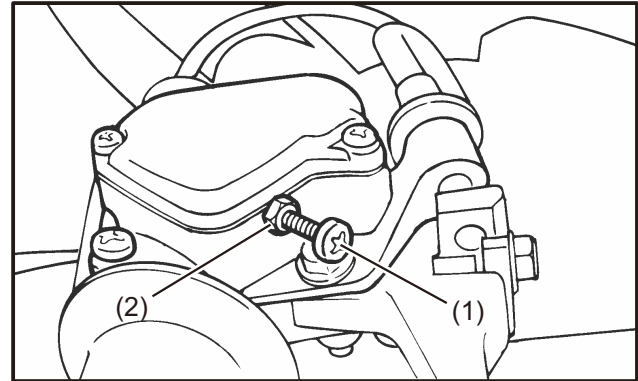

(1) Adjuster

(2) Locknut

Avoid wheelies and jumping. You may lose control of the machine or overturn.

**⚠ WARNING**

**POTENTIAL HAZARD**

**Attempting wheelies, jumps, and other stunts.**

**WHAT CAN HAPPEN**

**Increases the chance of an accident, including an overturn.**

**HOW TO AVOID THE HAZARD**

**Never attempt stunts, such as wheelies or jumps. Don't try to show off.**

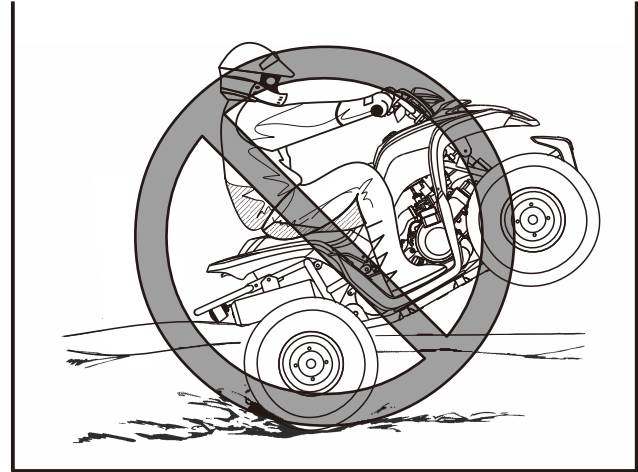

Know the terrain where you ride. Ride cautiously in unfamiliar areas. Stay alert for **holes, rocks, or roots** in the terrain, and **other hidden hazards** which may cause the machine to upset.

**⚠ WARNING**

**POTENTIAL HAZARD**

Failure to use extra care when operating this ATV on unfamiliar terrain.

**WHAT CAN HAPPEN**

You can come upon hidden rocks, bumps, or holes, without enough time to react. Could result in the ATV overturning or going out of control.

**HOW TO AVOID THE HAZARD**

Go slowly and be extra careful when operating on unfamiliar terrain. Always be alert to changing terrain conditions when operating the ATV.

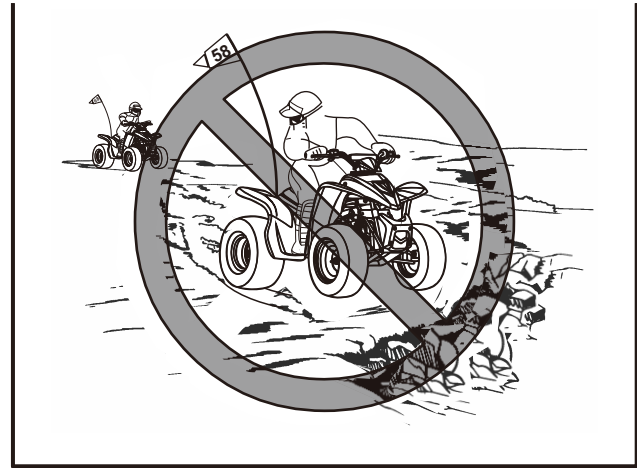

**⚠ WARNING**

**POTENTIAL HAZARD**

Failure to use extra care when operating on excessively rough, slippery or loose terrain.

**WHAT CAN HAPPEN**

Could cause loss of traction or vehicle control, which could result in an accident, including an overturn.

**HOW TO AVOID THE HAZARD**

Do not operate on excessively rough, slippery or loose terrain until you have learned and practiced the skills necessary to control the ATV on such terrain. Always be especially cautious on these kinds of terrain.

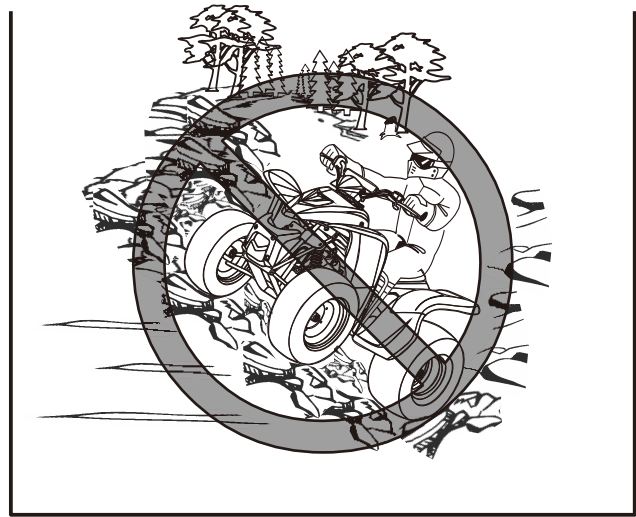

When riding in an area where you might not easily be seen, such as desert terrain, mount a caution flag on the machine. **DO NOT** use the flag pole bracket as a trailer hitch.

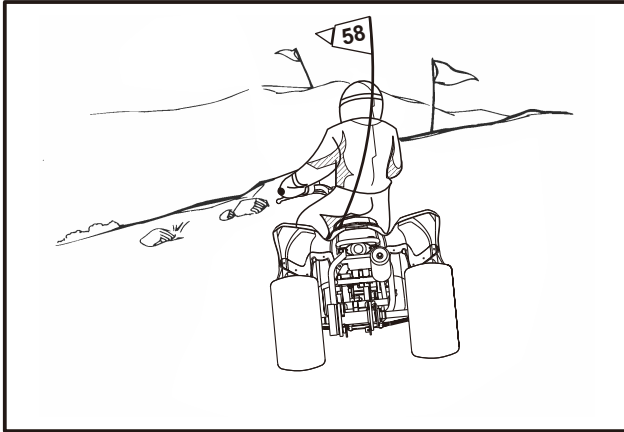

**⚠ WARNING**

**POTENTIAL HAZARD**

Operating in areas where you might not be seen by other off-road vehicles.

**WHAT CAN HAPPEN**

You could be in a collision. You could be injured.

**HOW TO AVOID THE HAZARD**

Always mount a caution flag on the machine to make you more visible. Watch carefully for other vehicles.

## **Exhaustsystem**

The exhaust on the machine is very hot during and following operation. To prevent burns, avoid touching the exhaust system. Park the machine in a place where pedestrians or children are not likely to touch it.

### **⚠ WARNING**

#### **POTENTIAL HAZARD**

**Hot exhaust system**

#### **WHAT CAN HAPPEN**

Someone touching the exhaust system during or after operation could be burned.

#### **HOW TO AVOID THE HAZARD**

**Do not touch the hot exhaust system.**

**Do not park the machine in a place where others might be likely to touch it.**

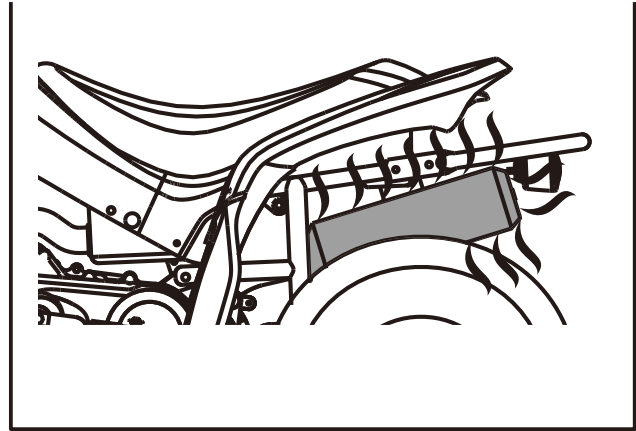



## **RIDING**

For your initial riding practice, select a safe area free of obstacles with a level surface of dirt or sand.



### **WARNING**

#### **POTENTIAL HAZARD**

**Starting or running the engine in a closed area.**

#### **WHAT CAN HAPPEN**

**Exhaust fumes are poisonous and may cause loss of consciousness and death within a short time.**

#### **HOW TO AVOID THE HAZARD**

**Always operate your machine in an area with adequate ventilation.**

Practice with the remote engine stop switch and throttle limiter adjusted as delivered until you are confident in braking and making turns.

#### **Remote engine stop switch for new riders**

The ATV has a remote engine stop switch. This allows the supervisor to follow close behind and stop the engine by pulling a tethered cord. Practice using it when your youngster first starts riding.

Pull the tether after the ATV is moving. The ATV may continue to roll for some distance. Watch the distance until the ATV stops. Be aware that this distance must be included in the stopping space of the ATV and that this distance may increase with speed.

### **Speed limiter for new riders**

Your ATV has an adjustable throttle limiter.

The screw and locknut in the lower throttle housing can be adjusted to limit throttle lever movement.

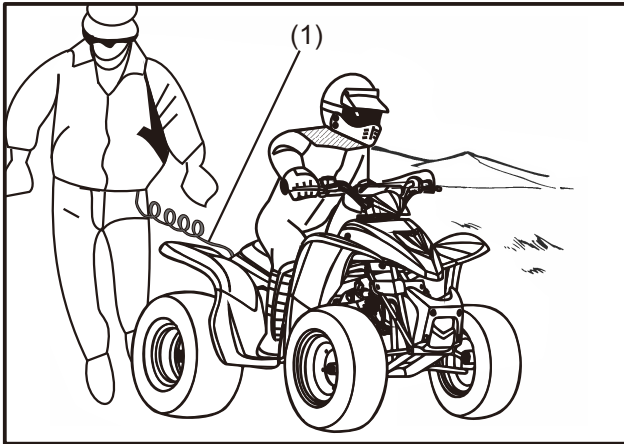

(1) Tethered cord

To adjust the throttle limiter:

1. Loosen the locknut.
2. Turn the throttle limiter screw clockwise to reduce throttle lever movement or counterclockwise to increase throttle lever movement.
3. Hold the screw in place and tighten the lock nut.

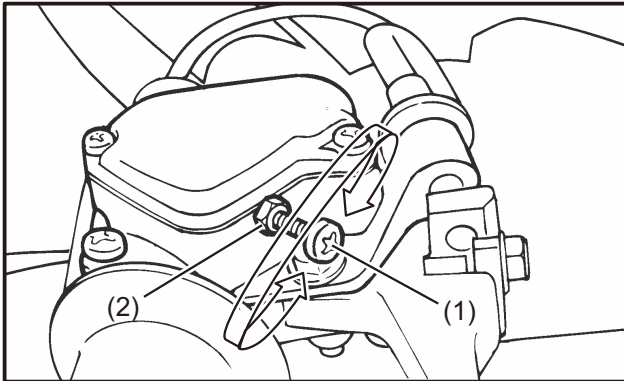

(1) Adjuster

(2) Locknut

## **BRAKING**

Practice starting and stopping at slow speeds. Gradually work up to faster starts and stops.

1. Steer straight ahead. Close the throttle completely, remove your thumb from the throttle lever.
2. Gently apply the brakes: pull both hand levers.

Gradually increase the lever pressure as you feel the brakes slowing your speed. The pressure used depends on your speed and the condition of the terrain you are riding. Slick, slippery or muddy ground requires gentler braking.

Pulling one or both brake levers too hard may cause the front and/or rear wheels to skid or slide out of control. If this happens, release all pressure on the lever(s) immediately. Steer straight ahead to regain control. Then gently reapply the brakes.

Independent use of only the front or rear brakes reduces stopping performance. Extreme braking may cause the wheels to lock, reducing control of the ATV

When possible, reduce speed or brake before entering a turn. Closing the throttle or braking in mid-turn may cause wheel slippage which will reduce control of your ATV.

## TURNING YOUR ATV

To achieve maximum traction while riding off-road, the two rear wheels are mounted solidly on one axle and turn together at the same speed. Therefore, unless the wheel on the inside of the turn is allowed to slip or lose some traction, the ATV will resist turning. A special turning technique must be used to allow the ATV to make turns quickly and easily. It is essential that this skill be learned first at low speed.



### WARNING

#### POTENTIAL HAZARD

Turning improperly

#### WHAT CAN HAPPEN

ATV could go out of control, causing a collision or overturn.

## HOW TO AVOID THE HAZARD

**Always follow proper procedures for turning as described in this Owner's Manual.**

**Practice turning at low speeds before attempting to turn at faster speeds. Do not turn at speeds too fast for your skills or the conditions.**

**Do not turn at excessive speeds.**

As you approach a curve, slow down and begin to turn the handlebars in the desired direction.

As you do so, put your weight on the footboard to the outside of the turn (opposite your desired direction) and lean your upper body into the turn. Use the throttle to maintain an even speed through the turn. This maneuver will let the wheel on the inside of the turn slip slightly, allowing the ATV to make the turn properly.

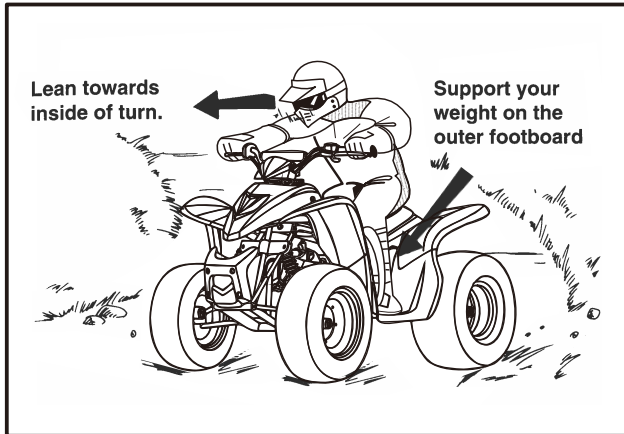

This procedure should be practiced at slow speed many times in a large off-road area with no obstacles. If an incorrect technique is used, your ATV may continue to go straight. If the ATV doesn't turn, come to a stop and then practice the procedure again. If the riding surface is slippery or loose, it may help to position more of your weight over the front wheels by moving forward on the seat.

Once you have learned this technique you should be able to perform it at higher speeds or in tighter curves.

Improper riding procedures such as abrupt throttle changes, or too much speed for the sharpness of the turn may cause the ATV to tip. It may also be necessary to the outside of the turn to avoid tipping over.

Remember: Avoid higher speeds until you are thoroughly familiar with the operation of your ATV.

## SLIDING AND SKIDDING

Care should be used when riding on loose or slippery surfaces since the ATV may slide. If unexpected and uncorrected, sliding could lead to an accident.

To reduce the tendency for the front wheels to slide in loose or slippery conditions, positioning your weight over the front wheels will sometimes help.

If the rear wheels of your ATV start to slide sideways, control can usually be regained (if there is room to do so) by steering in the direction of the slide. Applying the brakes or accelerating is not recommended until you have corrected the slide.

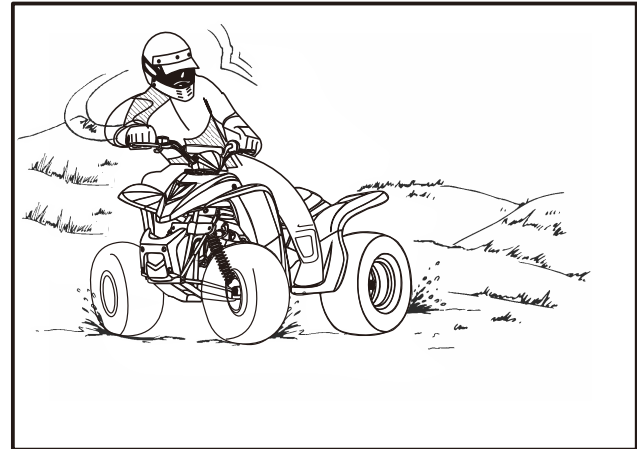
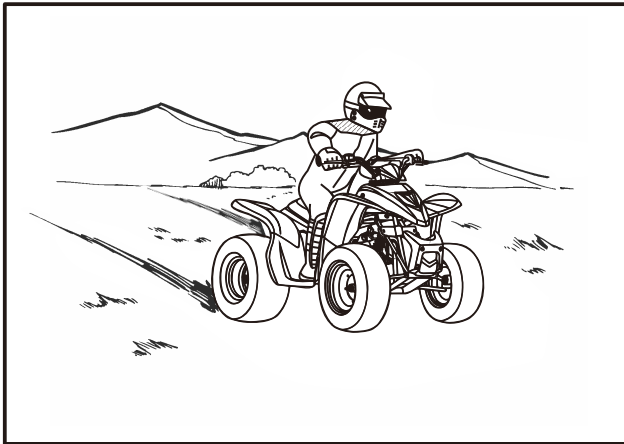

With practice, over a period of time, skill at controlled sliding can be developed. The terrain should be chosen carefully before attempting such maneuvers, since both stability and control are reduced. Bear in mind that sliding maneuvers should always be avoided on extremely slippery surfaces such as ice, since all control may be lost.

 **WARNING**

**POTENTIAL HAZARD**

**Skidding or sliding improperly.**

**WHAT CAN HAPPEN**

**You may lose control of this ATV. You may also regain traction unexpectedly, which may cause the ATV to overturn.**

**HOW TO AVOID THE HAZARD**

**Learn to safely control skidding or sliding by practicing at low speeds and on level, smooth terrain.**

**On extremely slippery surfaces, such as ice, go slowly and be very cautious in order to reduce the chance of skidding or sliding out of control.**



## **CLIMBING UPHILL**

Use proper riding techniques to avoid vehicle overturns on hills. Be sure that you can maneuver your ATV well on flat ground before attempting any incline and then practice riding first on gentle slopes. Try more difficult climbs only after you have developed your skill. In all cases avoid inclines with slippery or loose surfaces, or obstacles that might cause you to lose control.

### **WARNING**

#### **POTENTIAL HAZARD**

**Operating on excessively steep hills.**

#### **WHAT CAN HAPPEN**

**The vehicle can overturn more easily on extremely steep hills than on level surfaces or small hills.**

#### **HOW TO AVOID THE HAZARD**

**Never operate the ATV on hills too steep for the ATV or for your abilities.**

**Practice on smaller hills before attempting large hills.**

It is important when climbing a hill to make sure that your weight is transferred forward on the ATV. This can be accomplished by leaning forward and, on steeper inclines, standing on the footboards and leaning forward over the handlebars.

**⚠ WARNING**

**POTENTIAL HAZARD**

**Climbing hills improperly**

**WHAT CAN HAPPEN**

**Could cause loss of control or cause the ATV to overturn.**

**HOW TO AVOID THE HAZARD**

**Always follow proper procedures for climbing hills as described in this Owner's Manual.**

**Always check the terrain carefully before you start up any hill.**

**Never climb hills with excessively slippery or loose surfaces.**

**Shift your weight forward.**

**Never open the throttle suddenly.**

**The ATV could flip over backwards.**

**Never go over the top of any hill at high speed.**

**An obstacle, a sharp drop, or another vehicle or person could be on the other side of the hill.**

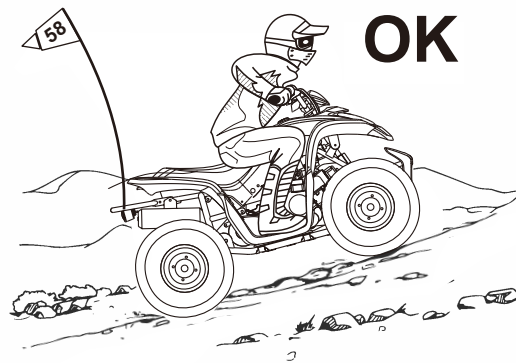

If you are climbing a hill and you find that you have not properly judged your ability to make it to the top, you should turn the ATV around while you still have forward motion (provided you have the room to do so) and go down the hill.

**⚠ WARNING**

**POTENTIAL HAZARD**

**Improperly crossing hills or turning on hills.**

**WHAT CAN HAPPEN**

**Could cause loss of control or cause the ATV to overturn.**

**HOW TO AVOID THE HAZARD**

**Never attempt to turn the ATV around on any hill until you have mastered the turning technique as described in the Owner's Manual on level ground. Be very careful when turning on any hill.**

**Avoid crossing the side of a steep hill if possible.**

**When crossing the side of a hill:**

**Always follow proper procedures as described in the Owner's Manual.**

**Avoid hills with excessively slippery or loose surfaces.**

**Shift your weight to the uphill side of the ATV.**

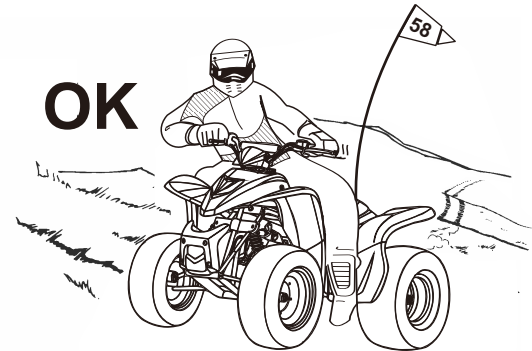

If your ATV has stalled or stopped and you believe you can continue up the hill, restart carefully to make sure you do not lift the front wheels which could cause you to lose control. If you are unable to continue up the hill, dismount the ATV on the uphill side. Physically turn the ATV around and then descend the hill.

If you start to roll backwards, DO NOT use the rear brake to stop. The ATV could easily tip over backwards. Instead, dismount the ATV immediately on the uphill side.

 **WARNING**

**POTENTIAL HAZARD**

**Stalling, rolling backwards or improperly dismounting while climbing a hill.**

**WHAT CAN HAPPEN**

**Could result in ATV overturning.**

**HOW TO AVOID THE HAZARD**

**Maintain steady speed when climbing a hill.**

**If you lose all forward speed:**

**Keep weight uphill.**

**Apply the brakes.**

**Lock parking brake, after you are stopped.**

**If you begin rolling backwards:**

**Keep weight uphill.**

**Never apply the rear brake while rolling backwards.**

**Apply the front brake.**

**When fully stopped, apply rear brake as well, and then lock parking brake.**

**Dismount on uphill side or to a side if pointed straight uphill. Turn the ATV around and remount, following the procedure described in the Owner's Manual.**



If the hill is not too steep and you have good footing, you may be able to walk the ATV back down the hill. Make sure your intended path is clear in case you lose control of the ATV. If you decide you can walk the ATV safely:

1. Stand with your body facing downhill, beside the vehicle so you can reach the rear brake lever with your left hand.
2. Be sure your legs are clear of the wheels.
3. Check your footing.
4. Then slowly and carefully back the ATV down the hill using the front brake lever to control speed.
5. If you lose control of the ATV, for your safety, get away from the vehicle,

If the hill is too steep or too slippery, or if you have any doubt whether you can safely walk the ATV back down the hill, leave the vehicle where it is and get help. If possible, block the wheels so the vehicle won't roll backwards.

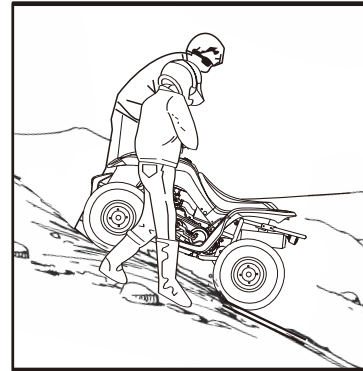
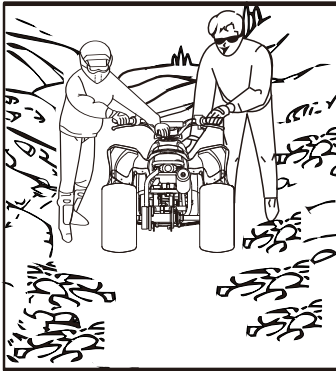

## **RIDING DOWNHILL**

When riding your ATV downhill, shift your weight as far to the rear and uphill side of the ATV as possible. Move back on the seat and sit with your arms straight. Improper braking may cause a loss of traction.

Use caution while descending a hill with loose or slippery surfaces. Braking ability and traction may be adversely affected by these surfaces.

Improper braking may also cause a loss of traction. Whenever possible, ride your ATV straight downhill. Avoid sharp angles which could allow the ATV to tip or roll over. Carefully choose your path and ride no faster than you will be able to react to obstacles which may appear.

## **WARNING**

### **POTENTIAL HAZARD**

**Going down a hill improperly.**

### **WHAT CAN HAPPEN**

**Could cause loss of control or cause the ATV to overturn.**

### **HOW TO AVOID THE HAZARD**

**Always follow proper procedures for going down hills as described in this Owner's Manual. Note: a special technique is required when braking as you go down a hill.**

**Always check the terrain carefully before you start down any hill.**

**Shift your weight backward.**

**Never go down a hill at high speed.**

**Avoid going down a hill at an angle that would cause the vehicle to lean sharply to one side. Go straight down the hill where possible.**

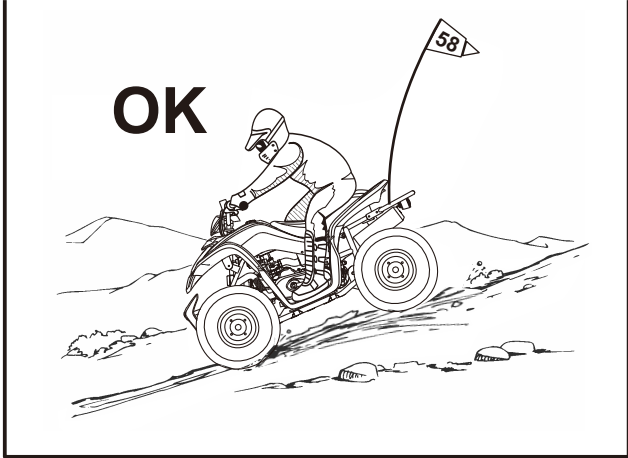



## **CROSSING A SLOPE**

Traversing a sloping surface on your ATV requires you to properly position your weight to maintain proper balance. Be sure that you have learned the basic riding skills on flat ground before attempting to cross a sloping surface. Avoid slopes with slippery surfaces or rough terrain that may upset your balance.

As you travel across a slope, lean your body in the uphill direction. It may be necessary to correct the steering when riding on loose surfaces by pointing the front wheels slightly uphill. When riding on slopes be sure not to make sharp turns either up or down hill.

If your ATV does begin to tip over, gradually steer in the downhill direction if there are no obstacles in your path. As you regain proper balance, gradually steer again in the direction you wish to travel.

## **WARNING**

### **POTENTIAL HAZARD**

**Improperly crossing hills or turning on hills.**

### **WHAT CAN HAPPEN**

**Could cause loss of control or cause the ATV to overturn.**

### **HOW TO AVOID THE HAZARD**

**Never attempt to turn the ATV around on any hill until you have mastered the turning technique as described in the Owner's Manual on level ground. Be very careful when turning on any hill. Avoid crossing the side of a steep hill if possible.**

### **When crossing the side of a hill:**

**Always follow proper procedures as described in the Owner's Manual.**

**Avoid hills with excessively slippery or loose surfaces.**

**Shift your weight to the uphill side of the ATV.**



## **RIDING OVER ROUGH TERRAIN**

Riding over rough terrain should be done with caution. Look out for obstacles which could cause damage to the ATV or could lead to an upset or accident. Be sure to keep your feet firmly mounted on the footboards at all time. Avoid jumping the ATV as loss of control and damage to the ATV may result.

### **WARNING**

#### **POTENTIAL HAZARD**

**Improperly operating over obstacles.**

#### **WHAT CAN HAPPEN**

**Could cause loss of control or a collision.**

**Could cause the ATV to overturn.**

#### **HOW TO AVOID THE HAZARD**

**Before operating in a new area, check for obstacles.**

**Never attempt to ride over large obstacles, such as large rocks or fallen trees. When you go over obstacles, always follow proper procedures as described in the Owner's Manual.**

## **CROSSING THROUGH SHALLOW WATER**

The ATV can be used to cross slow moving, shallow water of up to a maximum of 20 cm (7.9 inches) in depth. Before entering the water, choose your path carefully. Enter where there is no sharp drop off, and avoid rocks or other obstacles which may be slippery or upset the ATV. Drive slowly and carefully.

### **⚠ WARNING**

#### **POTENTIAL HAZARD**

**Operating this ATV through deep or fast flowing water.**

#### **WHAT CAN HAPPEN**

**Tires may float, causing loss of traction and loss of control, which could lead to an accident.**

#### **HOW TO AVOID THE HAZARD**

**Never operate this ATV in fast flowing water or in water deeper than that specified in your Owner's Manual.**

**Remember that wet brakes may have reduced stopping ability. Test your brakes after leaving water. If necessary, apply them several times to let friction dry out the linings.**



Test your brakes after leaving the water. Do not continue to ride your ATV without verifying that you have regained proper braking ability.

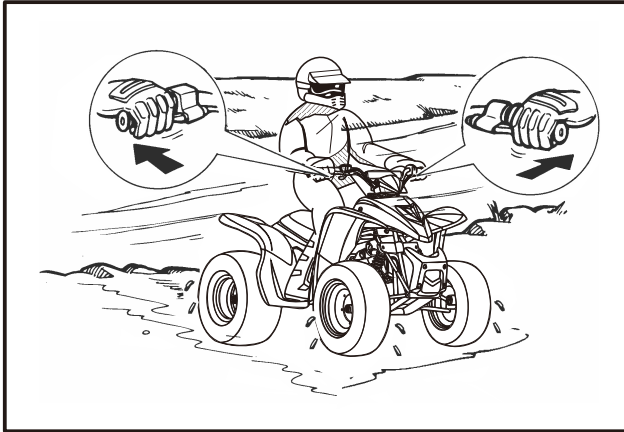

## **PARKING**

Always choose a level place to park. After bringing your ATV to a stop, hold the brakes while you shift into neutral. Then set the parking brake and turn the ignition switch OFF. If you're through parking for the day, also turn the fuel valve OFF.

## **WHAT TO DO IF**

This section is designed to be a reference guide only. Be sure to read each section on riding techniques completely.

## **WHAT TO DO....**

If your ATV doesn't turn when you want it to:

Bring the ATV to a stop and practice the turning maneuvers again. Be sure you are putting your weight on the footboard to the outside of the turn. Position your weight over the front wheels for better control.

If your ATV begins to tip while turning:

Lean more into the turn to regain balance. If necessary, gradually let off the throttle and /or steer to the outside of the turn.

If your ATV starts to slide sideways:

Steer in the direction of the slide if you have the room.

Applying the brakes or accelerating is not recommended until you have corrected the slide.

If your ATV can't make it up a hill you are trying to climb:

Turn the ATV around if you still have forward speed. If not, stop, dismount on the uphill side of the ATV and physically turn the ATV around. If the ATV starts to slip backwards DO NOT USE THE REAR BRAKE - the ATV may tip over on top of you. Dismount the ATV on the uphill side.

If your ATV is traversing a sloping surface:

Be sure to ride with your weight positioned towards the uphill side of the ATV to maintain proper balance. If the ATV starts to tip, steer down the hill (if there are no obstacles in your way) to regain balance. If you discover that the ATV is going to tip over, dismount on the uphill side.

If your ATV encounters shallow water:

Ride slowly and carefully through slow moving water, watching for obstacles. Be sure to let water drain from the ATV and **CHECK YOUR BRAKES FOR PROPER OPERATION** when you come out of the water. Do not continue to ride your ATV until you have regained adequate braking ability.

## PERIODIC MAINTENANCE AND ADJUSTMENT

Periodic inspection, adjustment and lubrication will keep your machine in the safest and most efficient condition possible. Safety is an obligation of the machine owner. The most important points of machine inspection, adjustment and lubrication are explained on the following pages.

### **WARNING**

#### **POTENTIAL HAZARD**

**Servicing an engine while it is running.**

#### **WHAT CAN HAPPEN**

**Moving parts can catch clothing or parts of the body, causing injury.**

**Electrical components can cause shocks or can start fires.**

#### **HOW TO AVOID THE HAZARD**

**Turn off the engine when performing maintenance unless otherwise specified.**

**Have KYMCO dealer perform service if you are not familiar with machine service.**

### **Tool kit**

A tool kit is provided with your ATV.

You are recommended to put the tool kit in the vinyl bag and always carry them on the seat reverse side.

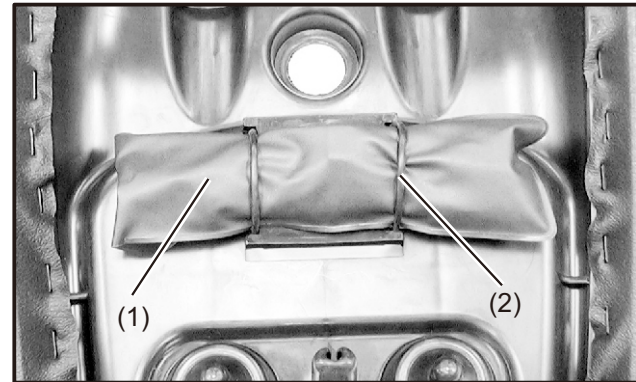

(1) Tool kit      (2) Rubber band



The tools in the kit are sufficient to perform routine maintenance and simple repairs. Any extensive work requiring additional tools should be performed by your authorized KYMCO dealer.

The tool kit includes the following items:

- (1) Air pressure gauge
- (2) Spark plug wrench
- (3) 10/12 mm wrench
- (4) Standard/Phillips screwdriver
- (5) Screwdriver handle
- (6) Tool bag
- (7) Rubberband

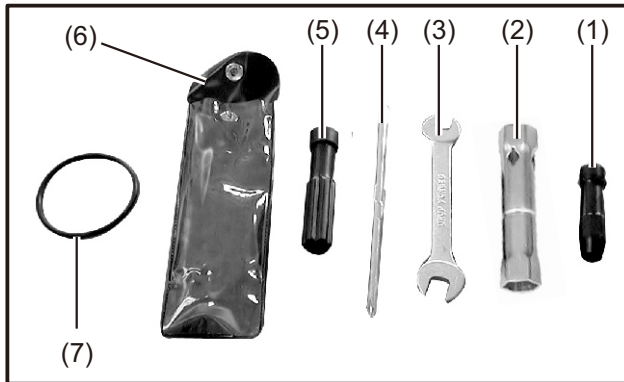

## **WARNING**

### **POTENTIAL HAZARD**

**Operating this ATV with improper modifications.**

### **WHAT CAN HAPPEN**

**Improper installation of accessories or modification of this vehicle may cause changes in handling which in some situation could lead to an accident.**

### **HOW TO AVOID THE HAZARD**

**Never modify this ATV through improper installation or use of accessories. All parts and accessories added to this vehicle should be genuine KYMCO or equivalent components designed for use on this ATV and should be installed and used according to instructions. If you have questions, consult an authorized KYMCO dealer.**

## PERIODIC MAINTENANCE/LUBRICATION

ITEM	ROUTINE	INITIAL			EVERY	
		1 month	3 months	6 months	6 months	1 year
<b>Engine oil</b>	<ul style="list-style-type: none"> <li>• Replace (Warm engine before draining).</li> </ul>	<input type="radio"/>		<input type="radio"/>	<input type="radio"/>	<input type="radio"/>
<b>Oil strainer*</b>	<ul style="list-style-type: none"> <li>• Clean.</li> <li>• Replace if necessary.</li> </ul>	<input type="radio"/>		<input type="radio"/>		<input type="radio"/>
<b>Transmission oil</b>	<ul style="list-style-type: none"> <li>• Check oil level/oil leakage.</li> <li>• Replace every 12 months.</li> </ul>	<input type="radio"/>				<input type="radio"/>
<b>V-belt*</b>	<ul style="list-style-type: none"> <li>• Check operation.</li> <li>• Replace if damage or excessive wear.</li> </ul>	<input type="radio"/>				<input type="radio"/>
<b>Air filter element (for engine and V-belt compartment)</b>	<ul style="list-style-type: none"> <li>• Clean.</li> <li>• Replace if necessary.</li> </ul>	Every 20~40 hours (More often in wet or dusty areas.)				
<b>Brake*</b>	<ul style="list-style-type: none"> <li>• Check operation and brake fluid/cable.</li> <li>• Replace brake pads/shoes if necessary.</li> </ul>	<input type="radio"/>	<input type="radio"/>	<input type="radio"/>	<input type="radio"/>	<input type="radio"/>
<b>Battery*</b>	<ul style="list-style-type: none"> <li>• Check specific gravity.</li> <li>• Check breather hose for proper operation.</li> <li>• Correct if necessary.</li> </ul>	<input type="radio"/>	<input type="radio"/>	<input type="radio"/>	<input type="radio"/>	<input type="radio"/>
<b>Carburetor*</b>	<ul style="list-style-type: none"> <li>• Check idle speed/starter operation.</li> <li>• Adjust if necessary.</li> </ul>		<input type="radio"/>	<input type="radio"/>	<input type="radio"/>	<input type="radio"/>
<b>Cylinder head cover breather system*</b>	<ul style="list-style-type: none"> <li>• Check breather hose for cracks or damage.</li> <li>• Replace if necessary.</li> </ul>			<input type="radio"/>	<input type="radio"/>	<input type="radio"/>
<b>Drive chain</b>	<ul style="list-style-type: none"> <li>• Check and adjust slack/alignment/clean/lube.</li> </ul>	<input type="radio"/>	<input type="radio"/>	<input type="radio"/>	<input type="radio"/>	<input type="radio"/>
<b>Spark plug</b>	<ul style="list-style-type: none"> <li>• Check condition.</li> <li>• Adjust gap and clean.</li> <li>• Replace if necessary.</li> </ul>	<input type="radio"/>	<input type="radio"/>	<input type="radio"/>	<input type="radio"/>	<input type="radio"/>
<b>Fuel line*</b>	<ul style="list-style-type: none"> <li>• Check fuel hose for cracks or damage.</li> <li>• Replace if necessary.</li> </ul>			<input type="radio"/>	<input type="radio"/>	<input type="radio"/>

ITEM	ROUTINE	INITIAL			EVERY	
		1 month	3 months	6 months	6 months	1 year
<b>Valves*</b>	<ul style="list-style-type: none"> <li>• Check valve clearance.</li> <li>• Adjust if necessary.</li> </ul>	<input type="radio"/>		<input type="radio"/>	<input type="radio"/>	<input type="radio"/>
<b>Exhaust system*</b>	<ul style="list-style-type: none"> <li>• Check leakage.</li> <li>• Retighten if necessary.</li> <li>• Replace gasket if necessary.</li> </ul>			<input type="radio"/>	<input type="radio"/>	<input type="radio"/>
<b>Wheels*</b>	<ul style="list-style-type: none"> <li>• Check balance/damage/runout.</li> <li>• Replace if necessary.</li> </ul>	<input type="radio"/>		<input type="radio"/>	<input type="radio"/>	<input type="radio"/>
<b>Wheel bearings*</b>	<ul style="list-style-type: none"> <li>• Check bearing assembly for looseness/damage.</li> <li>• Replace if damaged.</li> </ul>	<input type="radio"/>		<input type="radio"/>	<input type="radio"/>	<input type="radio"/>
<b>Steering system*</b>	<ul style="list-style-type: none"> <li>• Check operation.</li> <li>• Replace if damaged.</li> <li>• Check toe-in.</li> <li>• Adjust if necessary.</li> </ul>	<input type="radio"/>	<input type="radio"/>	<input type="radio"/>	<input type="radio"/>	<input type="radio"/>
<b>Knuckle shafts/ Steering shaft*</b>	<ul style="list-style-type: none"> <li>• Lubricate every 6 months.</li> </ul>			<input type="radio"/>	<input type="radio"/>	<input type="radio"/>
<b>Fittings and Fasteners*</b>	<ul style="list-style-type: none"> <li>• Check all chassis fittings and fasteners.</li> <li>• Correct if necessary.</li> </ul>	<input type="radio"/>	<input type="radio"/>	<input type="radio"/>	<input type="radio"/>	<input type="radio"/>
<b>Spark arrester†</b>	<ul style="list-style-type: none"> <li>• Clean</li> </ul>			<input type="radio"/>	<input type="radio"/>	<input type="radio"/>

\* : It is recommended that these items be serviced by a KYMCO dealer.

\*\* : Lithium soap base grease.

## Engine oil

### 1. Engine oil level measurement

- A. Place the machine on a level place.
- B. Warm up the engine for several minutes and stop it.
- C. Remove the dipstick and wipe it off with a clean rag. Insert the dipstick in the filler hole without screwing it in.

### NOTE:

Wait a few minutes until the oil level settles before checking.

D. Remove the dipstick and inspect the oil level.

E. The oil level should be between the maximum and minimum marks. If the level is low, add oil to raise it to the proper level.

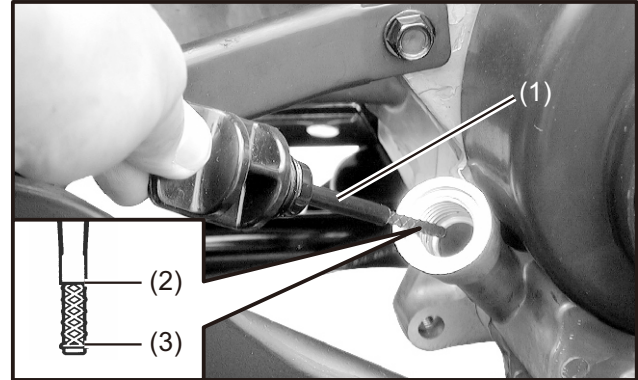

- (1) Dipstick/oil filler cap      (2) Maximum level mark  
(3) Minimum level mark

### CAUTION:

Be sure no foreign material enters the crankcase.

2-1. Engine oil replacement and oil filter cleaning

- A. Place the machine on a level place.
- B. Warm up the engine for several minutes and stop it.
- C. Place a container under the engine.
- D. Remove the oil filler cap and oil filter cap to drain the oil.



(1) Oil filter cap

**CAUTION:**

**Be sure no foreign material enters the crankcase.**

**When removing the drain plug, the compression spring, oil strainer and O-ring will fall out. Take care not to lose these parts.**

- E. Clean the oil strainer with solvent.
- F. Inspect the O-ring and replace if damaged.
- G. Reinstall the O-ring, oil strainer, compression spring and drain plug. Tighten the drain plug to specification.

**CAUTION:**

**Before reinstalling the drain plug, be sure to install the O-ring, compression spring and oil strainer.**

Tightening torque:

Oil filter cap (engine):

14.7 Nm (1.5 m·kg, 10.6 ft·lb)

H. Fill the engine with oil and install the oil filler cap.

Oil quantity:  
Engine oil:  
    Periodic oil change:  
        0.7 L (0.62 Imp qt, 0.74 US qt)  
    Total amount:  
        0.8 L (0.70 Imp qt, 0.84 US qt)

**CAUTION:**

**Be sure no foreign material enters the crankcase.**

I. Warm up the engine for several minutes at idle speed. Check for oil leakage while warming up.

**CAUTION:**

**If oil leakage is found, stop the engine immediately and check for the cause.**

## 2-2. Engine oil replacement

- A. Place the machine on a level place.
- B. Warm up the engine for several minutes and stop it.
- C. Place a container under the engine.
- D. Remove the oil filler cap and drain plug to drain the oil.

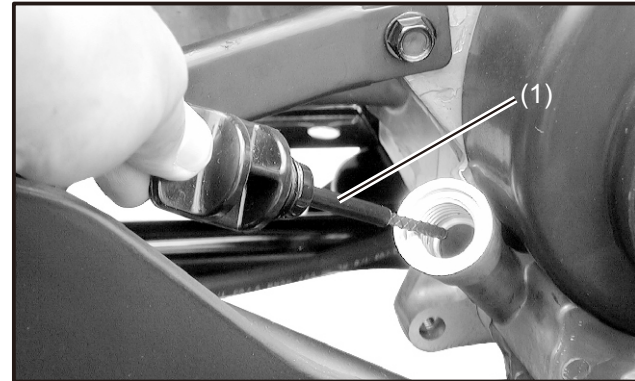

(1) Dipstick/oil filler cap

**CAUTION:**

**Be sure no foreign material enters the crankcase.**

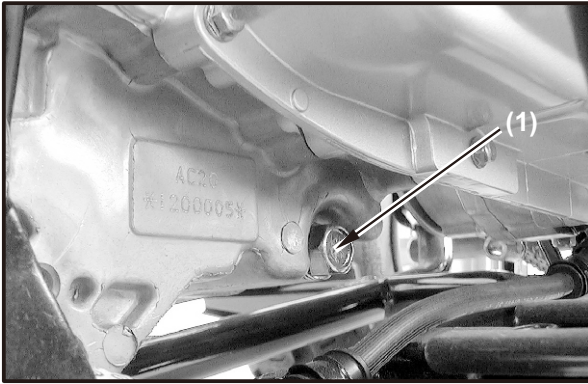

(1) Drain plug

Tightening torque:  
Drain plug (engine):  
25 N-m (2.5 m-kg, 18 ft-lb)

**CAUTION:**

**Be sure no foreign material enters the crankcase.**

- E. Reinstall the drain plug and tighten the drain plug to specification.
- F. Fill the engine with oil and install the oil filler cap.
- G. Warm up the engine for several minutes at idle speed. Check for oil leakage while warming up.

## Transmission oil

### 1. Transmission oil measurement

- A. Place the machine on a level place.
- B. Remove the oil filler bolt and check the oil level. It should be up to the brim of the hole. If the level is low, add oil to raise it to the proper level.
- C. Reinstall the oil filler bolt and tighten to specification.
- D. Reinstall the drain plug and tighten to specification.

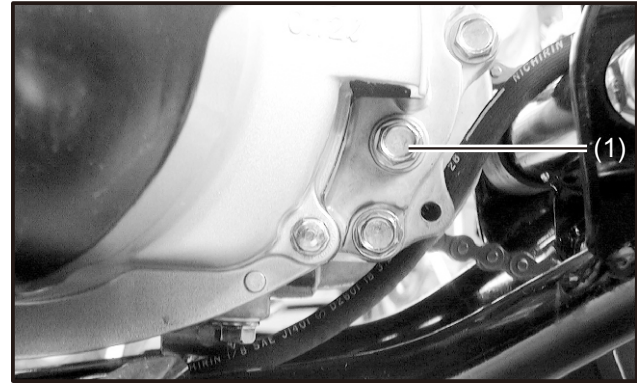

(1) Oil filler bolt/measurement hole

### Tightening torque

Oil filler bolt:

18 Nm (1.8 m-kg, 13 ft-lb)



## 2. Transmission oil replacement

- A. Place the machine on a level place.
- B. Place a container under the engine.
- C. Remove the oil filler bolt and drain plug to drain the oil.
- D. Reinstall the drain plug and tighten to specification.

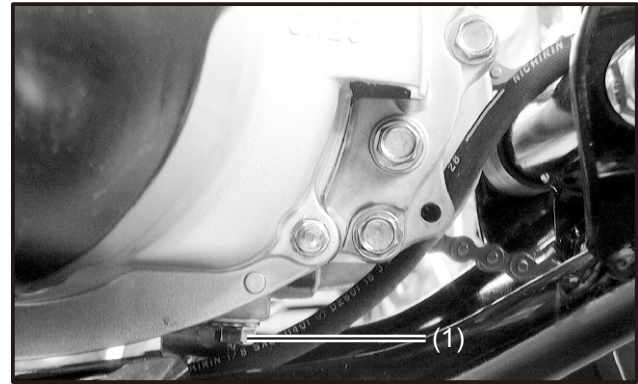

(1) Drain plug

Tightening torque

Drain plug:

18 Nm (1.8 m-kg, 13 ft-lb)

E. Fill the engine with oil and install the oil filler bolt.

Oil quantity:

Periodic oil change:

0.10 L (0.09 Imp qt, 0.11 US qt)

Total amount:

0.11 L (0.10 Imp qt, 0.12 US qt)

**CAUTION:**

**Be sure no foreign material enters the crankcase.**

Tightening torque

Oil filler bolt:

18 Nm (1.8 m·kg, 13 ft·lb)

F. Start the engine and warm up for a few minutes. While warming up, check for oil leakage. If oil leakage is found, stop the engine immediately and check for the cause.

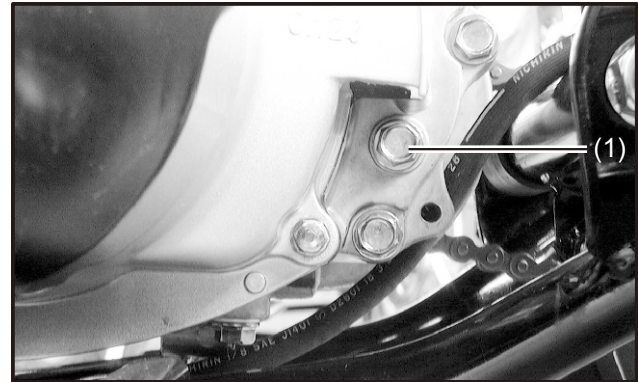

(1) Oil filler bolt

## Spark plug inspection

The spark plug is an important engine component and is easy to inspect. The condition of the spark plug can indicate the condition of the engine.

For example, a very white center electrode porcelain color could indicate an intake air leak or carburetion problem for that cylinder. Do not attempt to diagnose such problems yourself.

Instead, take the machine to a KYMCO dealer.

You should periodically remove and inspect the spark plug because heat and deposits will cause the spark plug to slowly break down and erode.

If electrode erosion becomes excessive, you should replace the spark plug with one of the proptype.

Standard spark plug:  
NGK CR7HSA

Before installing the spark plug, measure the electrode gap with a feeler gauge and adjust to specification.

Spark plug gap:  
0.6~0.7 mm (0.024~0.028 in)

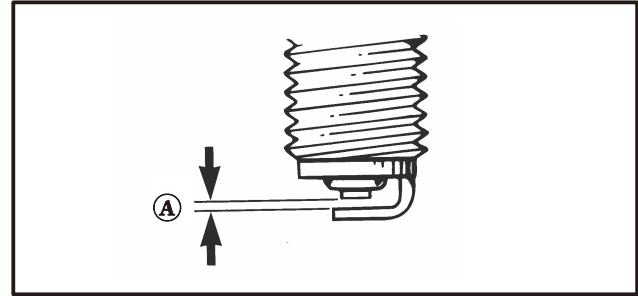

### A. Spark plug gap

When installing the spark plug, always clean the gasket surface and use a new gasket. Wipe off any grime from the threads and tighten to the specified torque.

Tightening torque:  
Spark plug:  
12.5 Nm (1.25 m.kg, 9.1 ft.lb)

### **Airfilter cleaning**

The air cleaner accumulates dust and must be cleaned periodically. If the ATV is ridden in dusty areas, the air cleaner must be cleaned at more frequent intervals than specified in the Maintenance Schedule. If the ATV is submerged in water, the air cleaner should be checked and water should be drained from the air cleaner housing before starting the engine.

To clean the air cleaner:

1. Remove the seat.
2. Remove the air filter case cover.

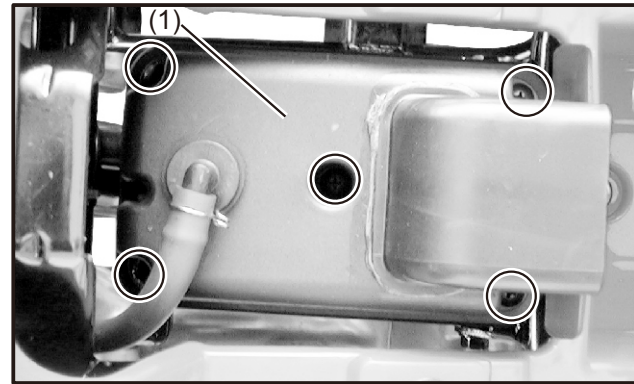

(1) Air filter case cover

3. Remove the air filter element, and separate it from the box.

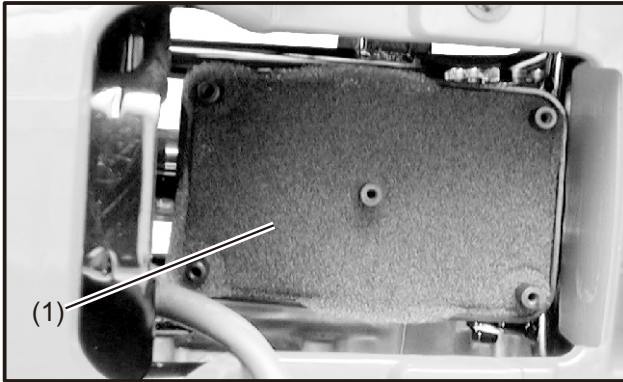

(1) Air filter element

4. Wash the element gently but thoroughly in solvent.

**⚠ WARNING**

**POTENTIAL HAZARD**  
Using low flash point solvents or gasoline to clean the air filter element.

**WHAT CAN HAPPEN**  
Low flash point solvents or gasoline can catch fire or explode.

**HOW TO AVOID THE HAZARD**  
Use parts cleaning solvent to clean the air filter element.

5. Squeeze the excess solvent out of the filter and let it dry.

**CAUTION:**

Do not twist the filter element when squeezing it.

6. Inspect the element. If damaged, replace it.
7. Apply quality foam air filter oil to the element. If foam air filter oil is not available, motor oil may be used.

**NOTE:**

The element should be wet but not dripping.

8. Reinstall the element to the air filter case.
9. Reinstall the element assembly and parts removed for access.

**Valve clearance adjustment**

The correct valve clearance changes with use, resulting in improper fuel/air supply or engine noise. To prevent this, the valve clearance must be adjusted regularly. This adjustment however, should be left to a professional KYMCO service technician.

## Idle speed adjustment

### NOTE:

A diagnostic tachometer must be used for this procedure.

1. Start the engine and warm it up for a few minutes at approximately 1,000 to 2,000 r/min. Occasionally rev the engine to 4,000 to 5,000 r/min. The engine is warm when it quickly responds to the throttle.
2. Connect the tachometer and set the idle to the specified idling speed by adjusting the throttle stop screw. Turn the screw in to increase engine speed, and out to decrease engine speed.

Specified idle speed:

2,000 r/min

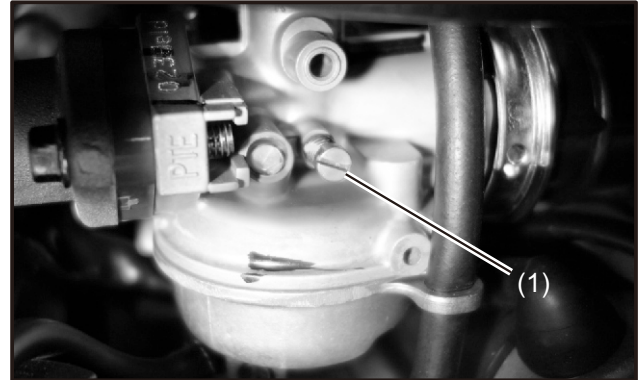

(1) Throttle stop screw

## Throttle lever adjustment

### NOTE:

Adjust the engine idling speed before adjusting the throttle lever free play.

To adjust throttle free play:

1. Slide the rubber sleeves back to expose the throttle cable adjuster.
2. Loosen the lock nut, then turn the adjuster to obtain the correct free play. (3 ~ 5 mm or 0.12 ~ 0.2 in)
3. Tighten the locknut and reinstall the sleeve.

Other checks:

Check the throttle cable for kinks and signs of wear that could cause stretching or failure. Lubricate the throttle cable with a commercially available lubricant to prevent premature wear and corrosion.

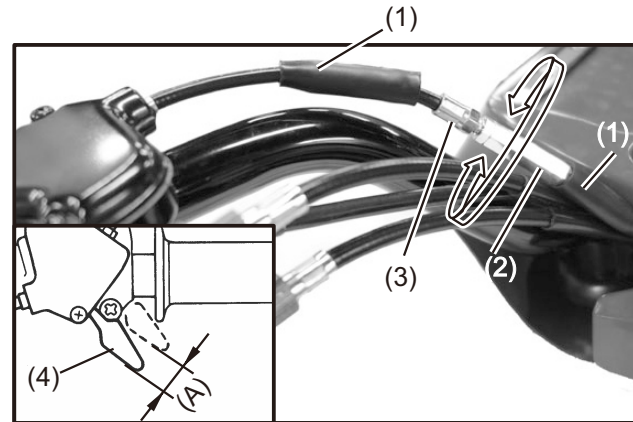

- (1) Rubber sleeve      (2) Cable adjuster  
(3) Locknut          (4) Throttle lever  
(A) 3~5 mm (0.12~0.2 in)



### Front brake shoe inspection

The checking of brake shoe wear will disassemble the brake. If the lining thickness below to the wear limit 2.0mm (0.08in), to replace the shoes as a set. These procedures should be performed by KYMCO dealer.

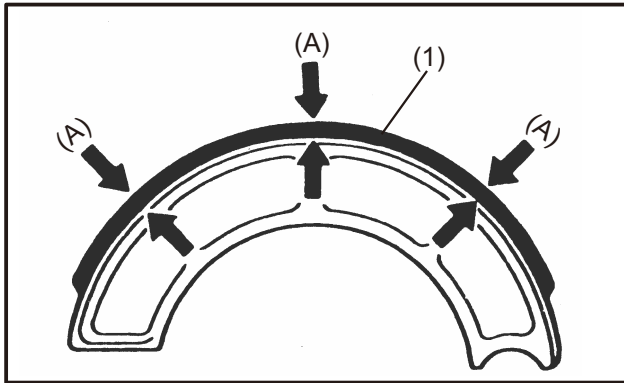

(1) Lining (A) Lining thickness

### Rear brake pads inspection

A wear indicator is provided on each brake. The indicators allows checking of brake pads wear. Check the position of the indicator. If the indicator reaches the wear limit line, ask a KYMCO dealer to replace the pads.

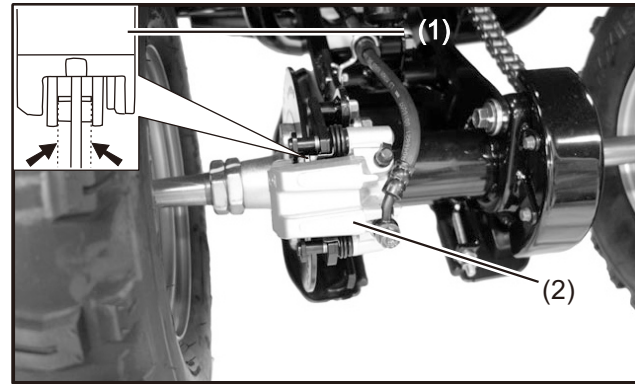

(1) Wear indicator (2) Rear brake

### Front brake lever free play adjustment

The front brake lever free play should be adjusted to 10~20 mm (0.4~0.8 in) at the tip of the brake lever. If the free play is incorrect, adjust as follows:

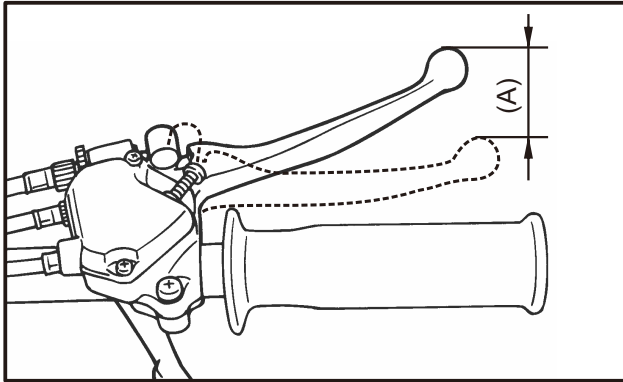

(A) Free play 10~20 mm (0.4~0.8 in)

1. Loosen the upper locknut and fully turn in the adjusting bolt.

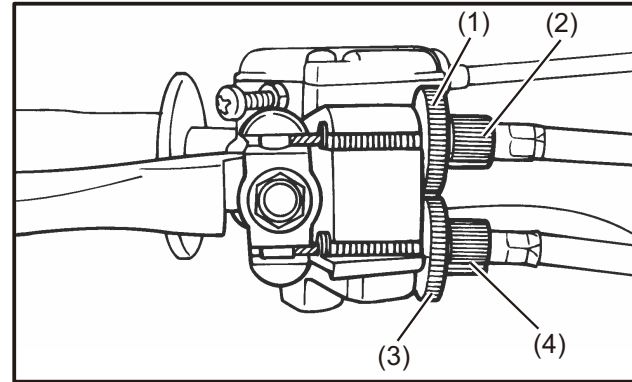

- |                   |                          |
|-------------------|--------------------------|
| (1) Upper locknut | (2) Upper adjusting bolt |
| (3) Lower locknut | (4) Lower adjusting bolt |

2. Loosen the lower locknut.
3. Turn the lower adjusting bolt until specified free play is obtained.

Specified free play:  
10~20 mm (0.4~0.8 in)

4. Tighten the lower locknut.

5. While applying the front brake, turn out the upper adjusting bolt until the upper and lower cable lengths are equal. The cable joint will become vertical.

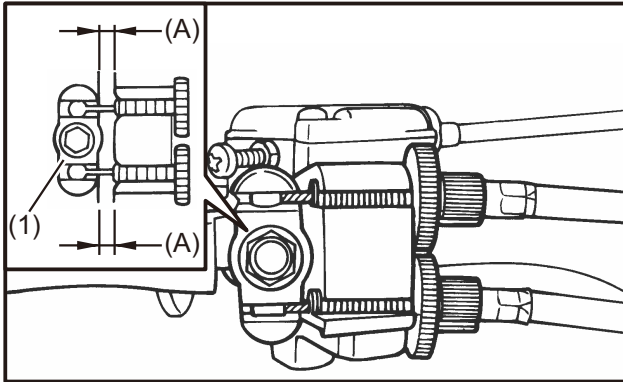

(1) Cable joint

(A) Cable length

6. Tighten the upper locknut.

## **⚠ WARNING**

### **POTENTIAL HAZARD**

**Operating with improperly serviced or adjusted brakes.**

### **WHAT CAN HAPPEN**

**You could lose braking ability, which could lead to an accident.**

### **HOW TO AVOID THE HAZARD**

**After servicing:**

- **Make sure the brakes operate smoothly and that the free play is correct.**
- **Make sure the brakes do not drag.**

**Replacement of brake components requires professional knowledge. These procedures should be performed by KYMCO dealer.**

## Brake fluid inspection

Check if the fluid level is below the lower level mark through the inspection window.

### **WARNING**

#### **POTENTIAL HAZARD**

**Brake fluid contacting the skin or eyes.**

#### **WHAT CAN HAPPEN**

**May cause irritation.**

#### **HOW TO AVOID THE HAZARD**

**Avoid contacting brake fluid with the skin or eyes. In case of contact, flush thoroughly with water and call a doctor if your eyes were exposed.**

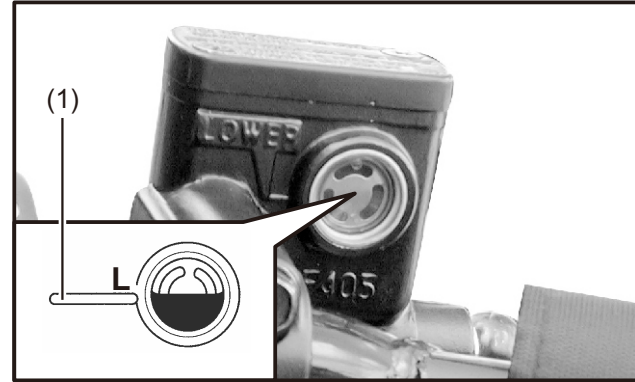

(1) Lower level mark (Hand Brake lever)

**NOTE:**

- As the brake pads wear, brake fluid level drops, automatically compensating for wear. There are no adjustments to perform, but fluid level and pad wear must be inspected periodically. The system must be inspected frequently to ensure there are no fluid leaks.
- If the brake lever travel become excessive and the brake pads are not worn beyond the recommended limit, There is probably air in the brake system and it must be bled. See your authorized KYMCO dealer for this service.

**CAUTION:**

- To prevent damage to the brake system, use only fluid from a sealed container. Never allow contaminants (dirt, water, etc.) to enter the brake fluid reservoir.
- Brake fluid can damage paint and plastic, so handle the fluid with care. When adding brake fluid, be sure the reservoir is horizontal before removing the cover to prevent accidental spilling.
- Use only DOT 4 brake fluid from a sealed container.

### Drive chain slack check

Inspect the drive chain while all tires are touching the ground. Check the slack at the position shown in the figure. The normal vertical deflection is approximately 10~20 mm (0.4~0.8in). If the deflection exceeds 20 mm (0.8 in), adjust the chain slack.

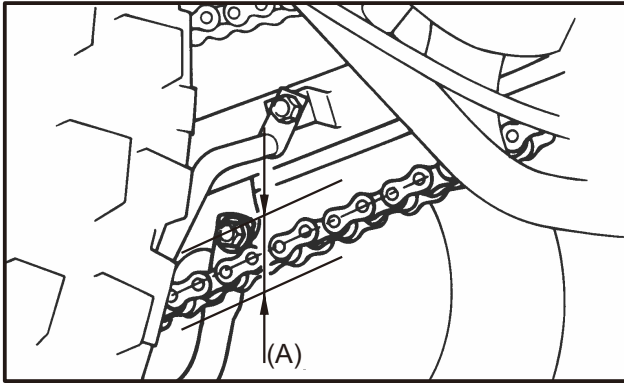

A. 10~20 mm (0.4~0.8 in)

### Drive chain slack adjustment

1. Loosen the upper and lower axle holding bolts.

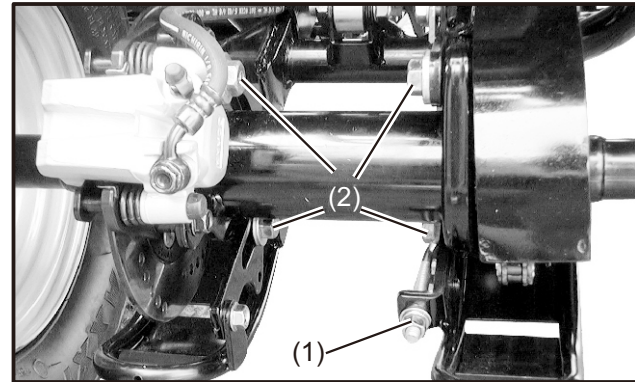

(1) Hub stopper nut

(2) Axle holding bolt x 4

2. Turn the adjusting nut, to decrease or increase chain slack.

3. Retighten the upper and lower axle holding bolts.

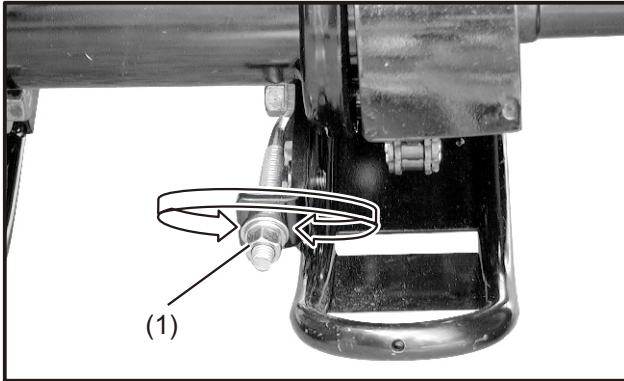

(1) Adjust nut

Tightening torque:

Axle holding bolts (upper):  
70 Nm (7.0 m·kg, 48 ft·lb)

**CAUTION:**

Too little of chain slack will overload the engine and other important parts. Keep the slack within the specified limit.

### Drive chain cleaning and lubrication

The drive chain is equipped with rubber O-rings between the chain plates. Steam cleaning, high-pressure washes, and certain solvents can damage these O-rings. Use only kerosene to clean the drive chain. Wipe it dry, and thoroughly lubricate it with SAE 30~50 motor oil. Do not use any other lubricants on the drive chain. They may contain solvents that could damage the O-rings.

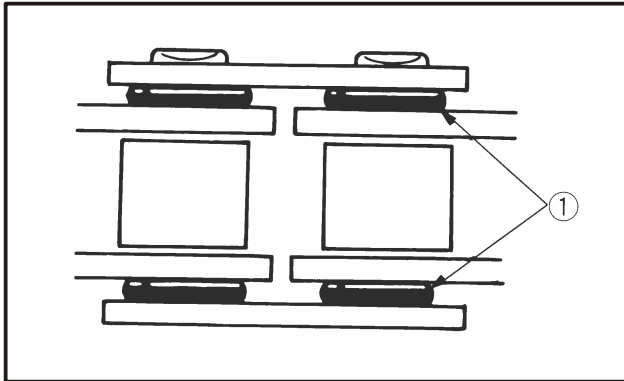

1. O-rings

### Cable inspection and lubrication

#### **WARNING**

#### **POTENTIAL HAZARD**

**Damaged control cables.**

#### **WHAT CAN HAPPEN**

**Corrosion can result when the outer covering of control cables becomes damaged.**

**Cables can also become frayed or kinked.**

**Operation of controls could be restricted, which could cause an accident or injury.**

#### **HOW TO AVOID THE HAZARD**

**Inspect cables frequently. Replace damaged cables.**

Lubricate the inner cables and the cable ends. If the cables do not operate smoothly, ask a KYMCO dealer to replace them.

Recommended lubricant:

KYMCO chain and cable lube or  
SAE 10W40 motor oil



### **Brake lever lubrication**

Lubricate the pivoting parts of the brake levers.

Recommended lubricant:

Lithium-soap-based grease  
(All-purpose grease)

### **Knuckle shaft and rear fork shaft lubrication**

Lubricate the pivot points using a grease gun.

Recommended lubricant:

Lithium-soap-based grease

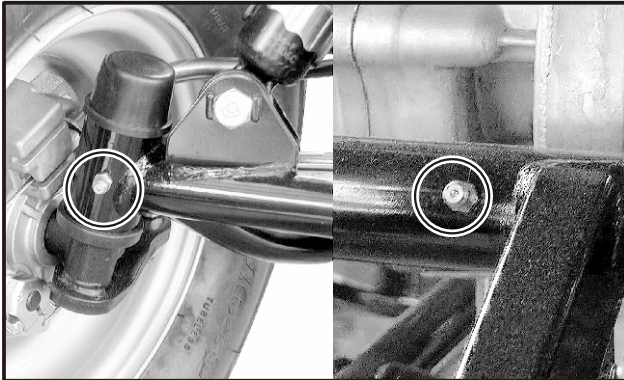

## Wheel removal

1. Elevate the wheel by placing a suitable stand under the frame.
2. Remove the nuts from the wheel.
3. Remove the wheel assembly.

Wheel nut torque:

Front: 45 Nm (4.6 m-kg, 33 ft-lb)

Rear: 45 Nm (4.6 m-kg, 33 ft-lb)

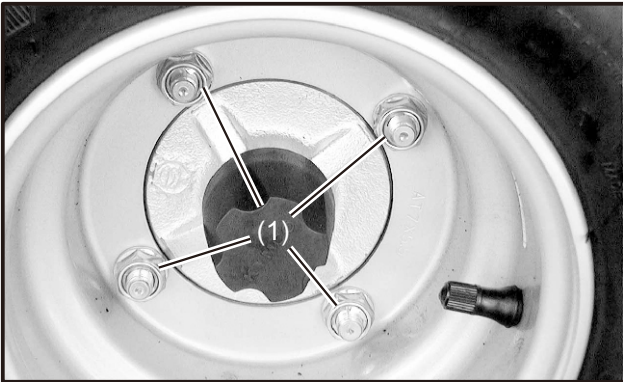

(1) Safe nut

## Wheel installation

When installing the wheel, reverse the removal procedure. Pay attention to the following.

## Battery

Your ATV battery is located in a compartment under the seat. The battery is sealed, so it is not necessary to check the electrolyte level or add distilled water. If the battery seems weak, see your authorized KYMCO dealer for information on recharging or replacement. If you replace the battery, choose one that is sealed and equivalent to the original. Be sure to read and follow all safety precautions indicated on the battery.

### CAUTION:

- Do not attempt to remove the caps from the battery cells as this may damage the battery.
- Although the battery is sealed, it vents explosive gases and should be handled with appropriate care.

### WARNING

#### POTENTIAL HAZARD

**Allowing open flames or sparks near the battery.**

#### WHAT CAN HAPPEN

**Gases may explode and possibly cause injury.**

#### HOW TO AVOID THE HAZARD

**Do not allow open flames or sparks near the battery.**

### NOTE:

- When the ATV is to be stored for an extended period, remove the battery from the vehicle and charge it fully. Then store it in a cool, dry place. If the battery is to be left on the vehicle, disconnect the negative cable from the battery terminal.
- Battery posts, terminals and related accessories contain lead and lead compounds. **Wash hands after handling.**

## Battery remove

1. Make sure the ignition switch is OFF.
2. Remove the seat.
3. Remove the battery cover, by removing the mount bolts.
4. Disconnect the negative (-) terminal lead from the battery first, then disconnect the positive (+) terminal lead.
5. Remove the battery.

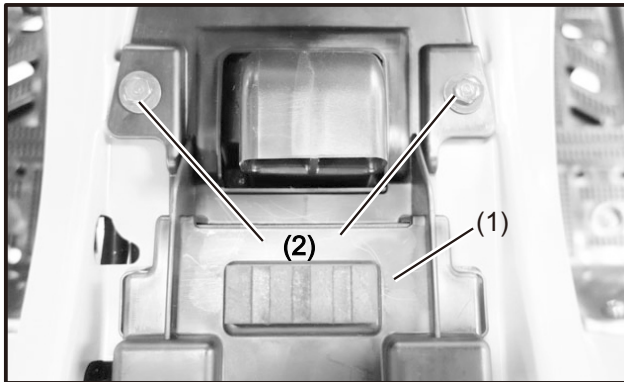

(1) Battery cover      (2) Mount bolt

## Battery installation

1. Install in the reverse order of removal.
2. Check all bolts and other fasteners are secure.
3. After installing the battery, check to see if the battery cables are routed correctly.



(1) Battery  
(2) Positive (+) terminal lead  
(3) Negative (-) terminal lead

## Fuse replacement

When frequent fuse failure occurs, it usually indicates a short circuit or an overload in the electrical system. See your authorized KYMCO dealer for repair.

### CAUTION:

To prevent accidental short-circuiting, turn off the ignition switch before checking or replacing a fuse.

### ⚠ WARNING

#### POTENTIAL HAZARD

Using an improper fuse.

#### WHAT CAN HAPPEN

An improper fuse can cause damage to the electrical system which could lead to a fire.

#### HOW TO AVOID THE HAZARD

Always use a fuse of the specified rating.  
Never use a material in place of the proper fuse.

## Fuse holder

The fuse holder is located in the storage box under the seat.

The specified fuses are: 7A

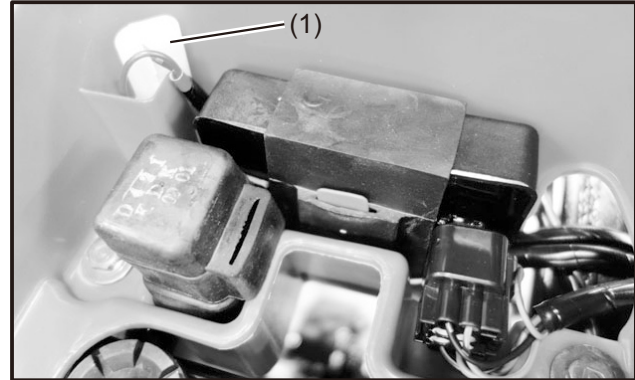

(1) Fuse holder

1. Lift the seat.
2. Open the fuse holders and lift out the fuse with the clips.

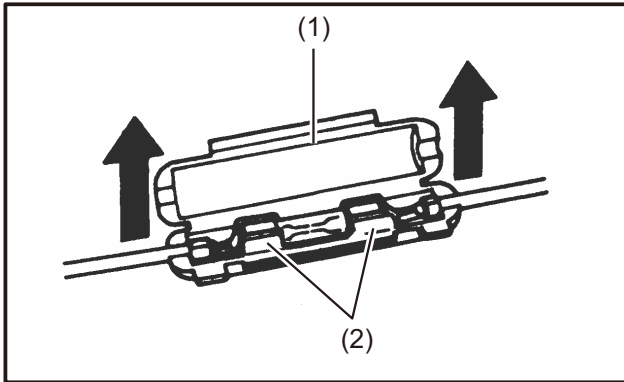

(1) Fuse holder      (2) Clip

3. Slide the old fuse out of the clips and discard it.

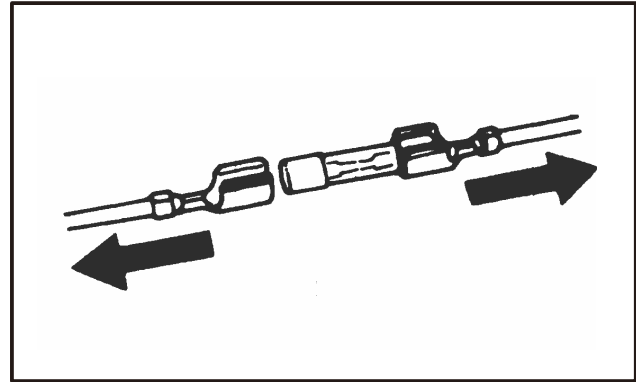

4. Slide the clips onto the ends of the new fuse, push them back into the fuse holder, and close the fuse holder.  
The spare fuse is on the battery cover.

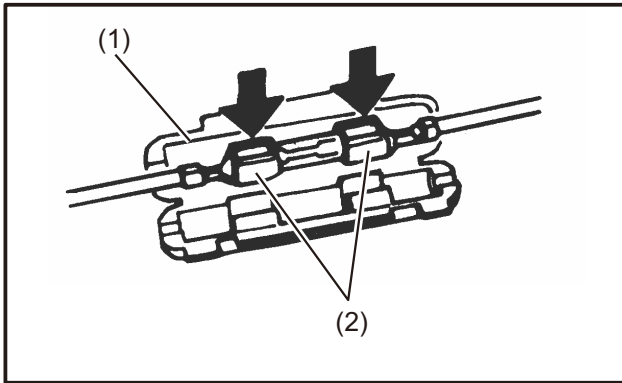

(1) Fuse holder      (2) Clip

**CAUTION:**

- Do not pry the clips open to get a fuse out; you could bend them and cause poor contact with the new fuse. A loose fuse could cause damage to the electrical system and even start a fire.
- After replacing the fuse, be sure return the fuse holder to its original location.

**Spark arrester cleaning**

Be sure the exhaust pipe and muffler are cool before cleaning the spark arrester.

1. Remove the bolt.

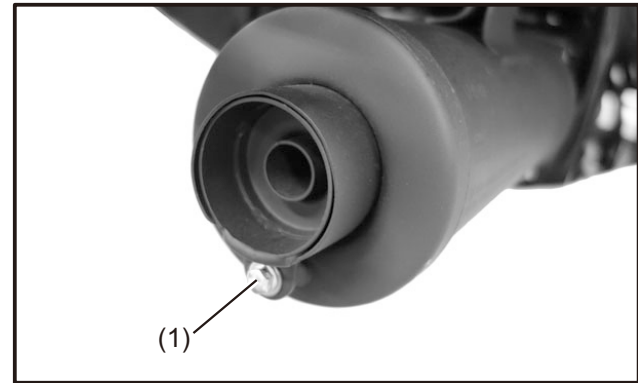

(1) Bolt

2. Remove the tailpipe by pulling it out of the muffler.
3. Tap the tailpipe lightly, then use a wire brush to remove any carbon deposits from the spark arrester portion of the tailpipe.

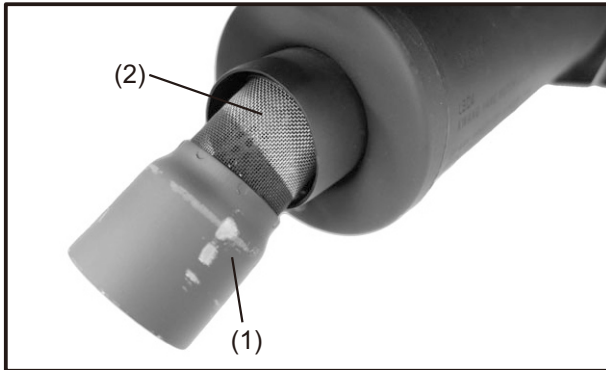

(1) Tailpipe      (2) Spark arrester

4. Insert the tailpipe into the muffler and align the screw holes.
5. Install the bolt and tighten it.

## **WARNING**

### **POTENTIAL HAZARD**

**Improper cleaning of the spark arrester.**

### **WHAT CAN HAPPEN**

**Could injure the eyes.**

**Could cause burns.**

**Could cause carbon monoxide poisoning, possibly leading to death.**

**Could start a fire.**

### **HOW TO AVOID THE HAZARD**

**When cleaning the spark arrester:**

**Always let the exhaust system cool prior to touching exhaust components.**

**Do not start the engine when cleaning the exhaust system.**



## Troubleshooting

Although KYMCO machines receive a rigid inspection before shipment from the factory, trouble may occur during operation. Any systems can cause poor starting and loss of power. The troubleshooting chart describes a quick, easy procedure for making checks. If your machine requires any repair, take it to a KYMCO dealer.

The skilled technicians at a KYMCO dealership have the tools, experience, and know-how to properly service your machine. Imitation parts may look like KYMCO parts, but they are often inferior. Consequently, they have a shorter service life and can lead to expensive repair bills.

## WARNING

### POTENTIAL HAZARD

**Checking the fuel system while smoking or near an open flame.**

### WHAT CAN HAPPEN

**Fuel can ignite or explode, causing severe injury or property damage.**

### HOW TO AVOID THE HAZARD

**Do not smoke when checking the fuel system. Make sure there are no open flames or sparks in the area, including pilot lights from water heaters or furnaces.**

## Troubleshooting chart

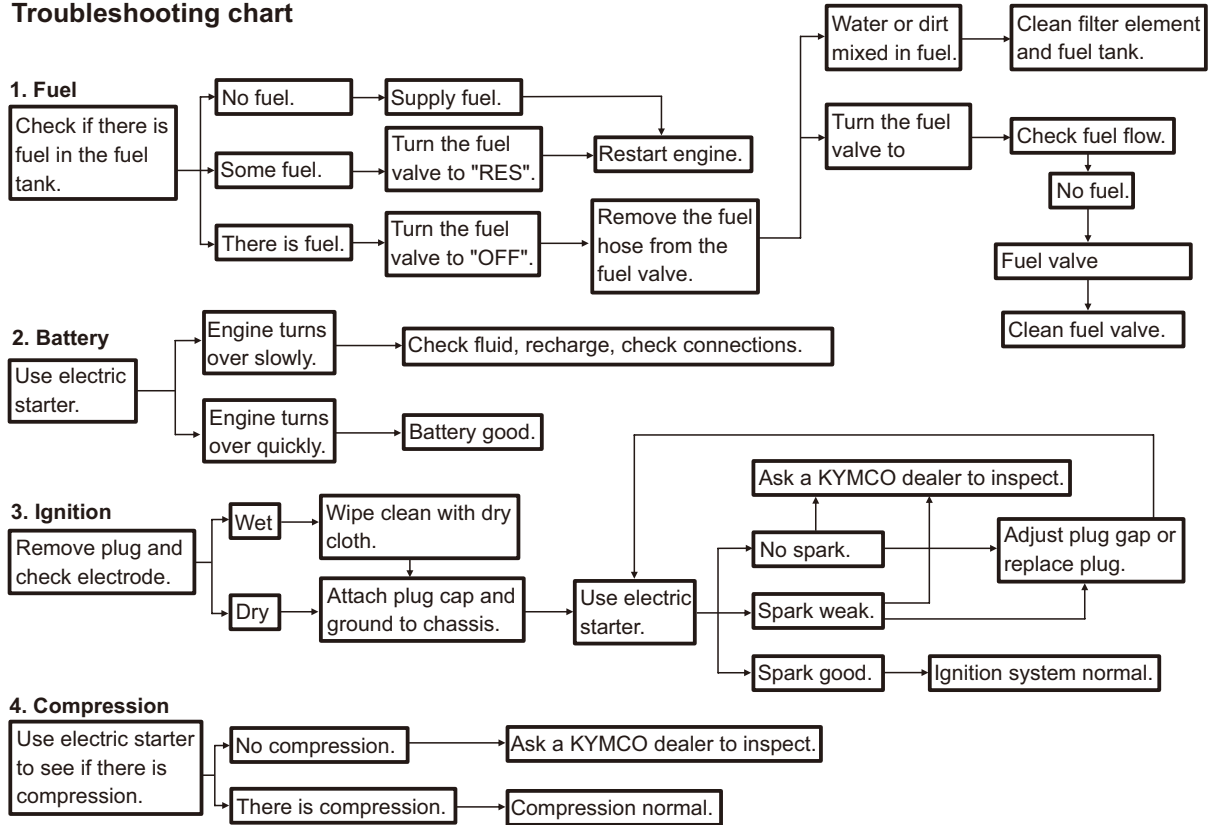

## CLEANING AND STORAGE

### A. CLEANING

Frequent, thorough cleaning of your machine will not only enhance its appearance but will improve its general performance and extend the useful life of many components.

1. Before cleaning the machine:
  - A. Block off the end of the exhaust pipe to prevent water entry. A plastic bag and strong rubber band may be used.
  - B. Make sure the spark plug and all filler caps are properly installed.
2. If the engine case is excessively greasy, apply degreaser with a paint brush. Do not apply degreaser to the chain, sprockets or wheel axles.
3. Rinse the dirt and degreaser off with a garden hose. Use only enough pressure to do the job.

### CAUTION:

**Excessive water pressure may cause water seepage and deterioration of wheel bearings, brakes, transmission seals and electrical devices. Many expensive repair bills have resulted from improper high pressure detergent applications such as those available in coin-operated car washers.**

4. Once the majority of the dirt has been hosed off, wash all surfaces with warm water and mild, detergent-type soap. An old toothbrush or bottle brush is handy for hard-to-get-at places.
5. Rinse the machine off immediately with clean water and dry all surfaces with a chamois, clean towel or soft absorbent cloth.
6. Dry the chain and lubricate it to prevent rust.

7. Clean the seat with a vinyl upholstery cleaner to keep the cover pliable and glossy.
8. Automotive type wax may be applied to all painted and chrome plated surfaces. Avoid combination cleaner-waxes. Many contain abrasives which may mar the paint or protective finish.  
When finished, start the engine and let it idle for several minutes.

 **WARNING**

**POTENTIAL HAZARD**

**Operation with wet brakes after washing.**

**WHAT CAN HAPPEN**

**Wet brakes may have reduced stopping ability, increasing the chance of an accident.**

**HOW TO AVOID THE HAZARD**

**Test the brakes after washing. Apply the brakes several times at slow speeds to let friction dry out the linings.**

## **B. STORAGE**

Before storing your ATV for an extended time, be sure you thoroughly check the vehicle for needed repairs and have them corrected. Otherwise, the repairs may be forgotten by the time you remove the vehicle from storage.

In addition, extended storage requires that you take the following steps to reduce the effects of deterioration from non-use of the vehicle:

1. Change the engine oil.
2. Drain the fuel tank and carburetor. Be sure to drain the fuel in a well-ventilated area, not in a garage.

### **WARNING**

#### **POTENTIAL HAZARD**

**Refueling this ATV or handling fuel improperly.**

#### **WHAT CAN HAPPEN**

**The fuel could explode or ignite.**

#### **HOW TO AVOID THE HAZARD**

**Always refuel this ATV and handle fuel in a well-ventilated area with the engine off. Do not smoke or allow flames or sparks in the area where fuel is handled.**

**Do not overfill the tank. Be careful not to spill fuel when refueling. After refueling, make sure the fuel fill cap is closed properly and securely.**

**If any fuel is spilled, make sure the area is dry before starting the engine.**

 **WARNING**

**POTENTIAL HAZARD**

**Prolonged contact of fuel with the skin.  
Breathing fuel vapor.**

**WHAT CAN HAPPEN**

**The fuel can cause skin irritation.  
Fuel vapor could cause lung damage.**

**HOW TO AVOID THE HAZARD**

**Avoid repeated or prolonged contact of fuel  
with the skin or breathing of fuel vapor.**

**KEEP OUT OF REACH OF CHILDREN.**

3. Remove the spark plug and pour one tablespoon (15 - 20 cc) of clean engine oil into the cylinder. Operate the starter for a few seconds to distribute the oil, then reinstall the spark plug, (Make sure the engine stop switch is OFF (  ) before pressing the starter button.)

4. Remove the battery and store it in an area protected from freezing temperatures and direct sunlight and out of the reach of children, slow charge the battery once a month.

 **WARNING**

**POTENTIAL HAZARD**

**Allowing open flames or sparks near the  
battery.**

**WHAT CAN HAPPEN**

**Gases may explode and possibly cause  
injury.**

**HOW TO AVOID THE HAZARD**

**Do not allow open flames or sparks near the  
battery.**

5. Wash and dry the ATV, and wax all painted surfaces.
6. Inflate the tires to their recommended pressures.
7. Place the ATV on blocks to raise all four tires off the ground.

## SPECIFICATIONS

Model	Mongoose 70s
Dimension: Overall length Overall width Overall height Seat height Wheel base Minimum ground clearance	1460 mm (57.87 in) 870 mm (34.25 in) 900 mm (35.43 in) 650 mm (25.59 in) 940 mm (37.00 in) 90 mm (3.54 in)
Basic weight: With oil and full fuel tank	110 kg (242.5 lbs)
Engine: Type Cylinder arrangement: Displacement Bore x stroke Compression ratio Starting system Lubrication system:	Air cooled 4-stroke, OHC Single cylinder 69.4 cm <sup>3</sup> (4.16 cu-in) 47X40 mm (1.88X1.6 in) 7.9:1 Electric starter and kick starter Wet sump

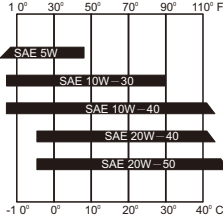
Model	Mongoose 70s
<p>Engine oil/transmission oil: Type Recommended engine oil classification:</p> <p>Recommended transmission Oil classification:</p> <p>Quantity Engine oil: Periodic oil change Total amount Transmission oil: Periodic oil change Total amount</p>	 <p>The chart shows recommended SAE oil grades for the Mongoose 70s. The x-axis represents temperature in degrees Fahrenheit (1, 30, 50, 70, 90, 110) and degrees Celsius (-1, 0, 10, 20, 30, 40). The recommended grades are: SAE 5W (from -1°C to 30°C), SAE 10W-30 (from 0°C to 70°C), SAE 10W-40 (from 0°C to 90°C), SAE 20W-40 (from 10°C to 110°C), and SAE 20W-50 (from 10°C to 40°C).</p> <p>API Service SG type or higher</p> <p>SEA#90</p> <p>0.7 L (0.62 Imp qt, 0.74 US qt) 0.8 L (0.7 Imp qt, 0.84 US qt)</p> <p>0.10 L (0.09 Imp qt, 0.11 US qt) 0.11 L (0.10 Imp qt, 0.12 US qt)</p>



Model	Mongoose 70s
Air filter: for engine for V-belt compartment	Wet type element Dry type element
Fuel: Type Tank capacity Reserve amount	UNLEADED FUEL 5.3 L (1.11 Imp gal, 1.38 US gal) 1.2 L (0.25 Imp gal, 0.31 US gal)
Carburetor: Type	PTE
Spark plug: Type Gap	NGK CR7HSA 0.6 ~ 0.7 mm (0.024 ~ 0.028 in)
Clutch: Type	Dry, centrifugal automatic
Brake: Front brake type Operation Rear brake type Operation	Drum brake Right hand operation Disk brake Left hand operation

Model	Mongoose 70s
Suspension: Front Rear	Swing axle Swing arm
Shock absorber: Front Rear	Coil spring/Oil damper Coil spring/Oil damper
Electrical: Ignition system Generator system Battery type	C.D.I. C.D.I. Magneto 12V, 4AH
Tire: Type Size: Front Rear	Tubeless 16X8-7 16X8-7
Bulb voltage, wattage*quantity: Taillight/Brake light	12V5W/12V21W X1

## NOISE REGULATION

### **TAMPERING WITH NOISE CONTROL SYSTEM PROHIBITED:**

Federal law prohibits the following acts or the causing thereof: (1) The removal or rendering inoperative by any person other than for purposes of maintenance, repair, or replacement of any device or element of design incorporated into any new vehicle for the purpose of noise control prior to its sale or delivery to the ultimate purchaser or while it is in use or (2) the use of the vehicle after such device or element of design has been removed or rendered inoperative by any person.

"AMONG THOSE ACTS PRESUMED TO CONSTITUTE TAMPERING ARE THE ACTS LISTED BELOW".

These acts include tampering with the following systems; i.e., Modification, removal, etc.

Exhaust system	Muffler Exhaust pipe Silencer
Intake system	Air cleaner case Air cleaner element Intake duct

## MAINTENANCE RECORD

Copies of work orders and/or receipts for parts you purchase and install will be required to document maintenance done in accordance with the warranty. The chart below is printed only as a reminder to you that the maintenance work is required. It is not acceptable proof of maintenance work.

MAINTENANCE INTERVAL	DATE OF SERVICE	MILEAGE	SERVICING DEALER NAME AND ADDRESS	REMARKS
1Month				
3Months				
6Months				
12Months				
18Months				
24Months				
30Months				
36Months				
42Months				
48Months				
54Months				
60Months				

## INDEX

	Page		Page
<b>A</b>		<b>D</b>	
Accessories.....	49, 55	Drive chain cleaning and lubrication.....	117
AGE RECOMMENDATION.....	A	Drive chain slack adjustment.....	115
Air filter cleaning .....	105	Drive chain slack check.....	115
		During operation.....	63
<b>B</b>		<b>E</b>	
Brake fluid inspection.....	113	Engine break-in.....	46
Brake lever lubrication.....	118	Engine and transmission oil.....	39
Battery.....	120	Engine oil.....	97
		Engine stop switch.....	22
<b>C</b>		Exhaust system.....	69
Cable inspection and lubrication.....	117		
Chain.....	40		
CLEANING.....	128		
CLIMBING UPHILL.....	78		
CONTENTS.....	E		
CONTROL FUNCTIONS.....	21		
CROSSING A SLOPE.....	86		
CROSSING THROUGH			
SHALLOW WATER.....	89		

(Cont'd)

	Page		Page
<b>F</b>		<b>I</b>	
Fittings and fasteners.....	40	Idle speed adjustment.....	108
Flag pole bracket.....	34	Ignition switch.....	21
Frame and engine serial number.....	17	IMPORTANT NOTICES.....	A
Front brake.....	28	<b>K</b>	
Front brake lever free play adjustment.....	111	Key identification number.....	16
Front brake shoe inspection.....	110	Kick starter.....	24
Fuel.....	37	Knuckle shaft and rear fork	
Fuse replacement.....	122	Shaft lubrication.....	118
Fuel tank cap.....	30	<b>L</b>	
Fuel valve.....	31	Lights.....	40
<b>H</b>			
Handlebar switches.....	22		
Headlight switch.....	23		

(Cont'd)

	Page
<b>N</b>	
No Modifications.....	56
<b>O</b>	
OPERATION.....	44
<b>P</b>	
PARKING.....	47, 90
Parking brake.....	29
Parking on a slope.....	48
Parts location.....	18
PERIODIC MAINTENANCE/ LUBRICATION.....	95
PERIODIC MAINTENANCE AND ADJUSTMENT.....	93
PREFACE.....	D
PRE-OPERATION CHECKS.....	35, 53

	Page
<b>R</b>	
Rear brake.....	28
Rear brake pads inspection.....	110
Remote engine stop switch.....	25
RIDING DOWNHILL.....	84
RIDING OVER ROUGH TERRAIN.....	88
Riding Your ATV.....	50
<b>S</b>	
SAFETY INFORMATION.....	5
Seat.....	33
SLIDING AND SKIDDING.....	76
Spark arrester cleaning.....	124
Spark plug inspection.....	104
SPECIAL MESSAGES.....	C
SPECIFICATIONS.....	132
Speed limiter.....	27, 64
Starter button .....	23
Starting engine.....	44
STORAGE.....	130
Storage compartment.....	34
Switches.....	40

(Cont'd)

## Page

### T

Throttle lever.....	26, 40
Throttle lever adjustment.....	109
Tires.....	41
Tire wear limit.....	43
Tool kit.....	93
Transmission oil .....	101
Troubleshooting .....	126
Troubleshooting chart .....	127
TURNING YOUR ATV.....	74

### V

Valve clearance adjustment.....	107
---------------------------------	-----

### W

Warning information.....	3
Wheel installation.....	119
Wheel removal.....	119
Weight limits.....	54