



KWANG YANG MOTOR CO.,LTD.



Owner's Manual

IMPORTANT NOTICES

READ THIS MANUAL CAREFULLY

Your Owner's Manual contains important information on safety, operation, and maintenance. Anyone who operates this ATV should carefully read and understand the contents of this manual before riding the vehicle.

AGE RECOMMENDATION

The minimum recommended age for this ATV model is 16. Children under age 16 should never operate this vehicle.

RIDER TRAINING

Anyone who operates this vehicle should get proper instruction.

USE ATV

Please check your local riding laws and regulations before operating this machine.

SPECIAL MESSAGES

KYMCO provides many important safety messages both in this manual and on the vehicle. For your safety and the safety of others, pay special attention to all warnings preceded by this alert symbol . Failure to follow the warnings contained in this manual can result in SERIOUS INJURY or DEATH.



Indicates a strong possibility that serious injury or death may result if instructions are not followed.

CAUTION

Indicates a possibility that equipment or property damage could result if instructions are not followed.

Note:

Gives helpful information

The Owner's Manual should be considered a permanent part of your ATV. It should remain with the vehicle at all times and stay with the ATV if it is sold.

PREFACE

Congratulations on your purchase of the KYMCO ATV. KYMCO take pride in a worldwide reputation for quality-in research, design, production and service.

For replacement parts and accessories, we recommend genuine KYMCO products. They've been specially designed for your vehicle and manufactured to meet KYMCO's demanding standards.

This manual will provide you with a good basic understanding of the features and operation of this machine. This manual includes important safety information. It provides information about special techniques and skills necessary to ride your machine. It also includes basic maintenance and inspection procedures. If you have any questions regarding the operation or maintenance of your machine, please consult a KYMCO dealer.

We wish you many years of safe and enjoyable riding.

While reading this manual, remember:



Indicates a strong possibility that serious injury or death may result if instructions are not followed.

All information in this publication is based on the latest product information available at the time of approval for printing. KWANG YANG MOTOR CO.,LTD Reserves the right to make changes at any time without notice and without incurring any obligation.

CONTENTS

	Page		Page
LOCATION OF THE WARNING AND SPECIFICATION LABELS.....	1	CONTROL FUNCTIONS.....	17
		IGNITION SWITCH.....	17
		INSTRUMENTS AND INDICATOR.....	18
		Multi-function display.....	20
SAFETY INFORMATION.....	4	LEFT HANDLEBAR SWITCHES.....	27
		Horn button.....	27
		Turn signal switch.....	27
		Headlight dimmer switch.....	28
		Hazard switch.....	29
		Start switch.....	30
DESCRIPTION AND MACHINE IDENTIFICATION.....	9	RIGHT HANDLEBAR SWITCH	
IDENTIFICATION NUMBER		31
RECORDS.....	9	2WD/4WD select switch	31
KEY IDENTIFICATION NUMBER.....	9	TO JUMP START YOUR VEHICLE	32
FRAME SERIAL NUMBER.....	10	THROTTLE LEVER.....	33
ENGINE SERIAL NUMBER.....	11	SPEED LIMITER.....	34
PARTS LOCATION.....	12		

(Cont'd)

	Page
FRONT BRAKE LEVER.....	35
REAR BRAKE LEVER.....	35
BRAKE PEDAL.....	35
PARKING BRAKE.....	36
LOCKING STEERING.....	37
DRIVE SELECT LEVER.....	38
FUEL TANK	39
FUEL SYSTEM.....	39
SPARK PLUG INSPECTION.....	41
BATTERY INSPECTION.....	42
SEAT.....	43
FLAG POLE BRACKET.....	44
TRAILER HITCH.....	44
OWNER'S MANUAL STORAGE COMPARTMENT.....	45
ACCESSORY SOCKET.....	46

	Page
PRE-OPERATION CHECKS.....	47
DRIVE SELECT LEVER	48
Drive select lever adjustment.....	50
FRONT AND REAR BRAKES.....	52
FUEL.....	53
DRIVE SHAFT BOOTS.....	54
ENGINE OIL	55
FINAL GEAR OIL.....	56
DIFFERENTIAL GEAR OIL	56
THROTTLE LEVER.....	57
FITTINGS AND FASTENERS.....	57
LIGHTS.....	57
SWITCHES.....	57
TIRES.....	58
How to measure tire pressure	59
Tire wear limit	60
COOLANT.....	60

(Cont'd)

	Page		Page
OPERATION.....	62	RIDING YOUR ATV	75
STARTING A COLD ENGINE.....	62	GETTING TO KNOW YOUR ATV	76
STARTING A WARM ENGINE.....	66	RIDE WITH CARE AND GOOD	
WARMING UP.....	66	JUDGEMENT.....	77
DRIVE SELECT LEVER OPERATION		APPAREL.....	80
AND REVERSE DRIVING.....	67	PRE-OPERATION CHECKS.....	82
ENGINE BREAK-IN.....	69	LOADING AND ACCESSORIES.....	84
PARKING.....	70	Loading and operational guidelines...84	
Parking on a slope.....	71	Accessories.....	85
ACCESSORIES	72	MODIFICATIONS.....	86
LOADING	73	No modifications.....	86
		DURING OPERATION.....	87
		EXHAUST SYSTEM.....	89
		PRACTICING.....	90
		TURNING YOUR ATV	91
		CLIMBING UP SLOPE.....	92
		RIDING DOWN SLOPE.....	98
		PARKING.....	99
		WHAT TO DO IF	100
		WHAT TO DO	100

(Cont'd)

	Page
PERIODIC MAINTENANCE AND ADJUSTMENT.....	101
TOOL KIT/	
TOOLKIT COMPARTMENT.....	101
PERIODIC MAINTENANCE/ LUBRICATION.....	103
ENGINE OIL	106
FINAL GEAR OIL.....	113
DIFFERENTIAL GEAR OIL ..	115
SPARK PLUG INSPECTION.....	117
SPARK ARRESTER.....	118
AIR FILTER CLEANING.....	120
AIR CLEANER HOUSING DRAIN TUBE.....	123
IDLE SPEED INSPECTION	124
THROTTLE LEVER ADJUSTMENT....	125
VALVE CLEARANCE ADJUSTMENT..	126
FRONT BRAKE PADS INSPECTION...	126
REAR BRAKE PADS INSPECTION.....	127

	Page
BRAKE FLUID INSPECTION.....	127
COOLING SYSTEM INSPECTION.....	129
Engine overheating.....	131
WHEEL REMOVAL.....	132
WHEEL INSTALLATION.....	132
BATTERY.....	134
Battery remove.....	135
Battery installation.....	135
FUSE REPLACEMENT.....	136
HEADLIGHT BEAM ADJUSTMENT....	137
DRIVE SHAFT BOOTS.....	137
CABLE INSPECTION AND LUBRICATION.....	138
TROUBLESHOOTING	139
Troubleshooting chart.....	140

(Cont'd)

	Page
CLEANING AND STORAGE.....	141
A. CLEANING	141
B. STORAGE	143
 SPECIFICATIONS.....	 145
 NOISE REGULATION.....	 149
 MAINTENANCE RECORD.....	 150

LOCATION OF THE WARNING AND SPECIFICATION LABELS

WARNING INFORMATION

Anyone who rides the vehicle should read and understand this information before riding. They contain important information for safe and proper operation of your ATV.

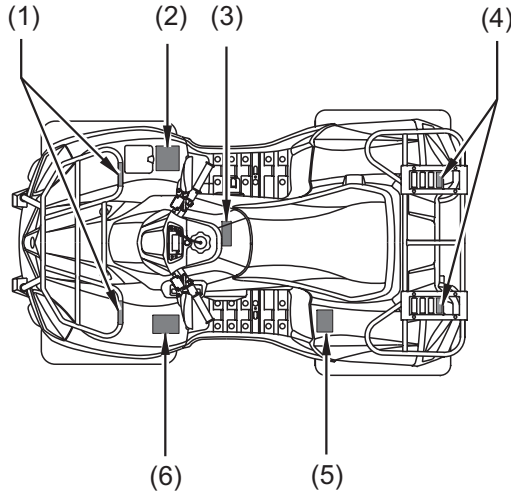

The labels should be considered as permanent parts of the vehicle. If a label comes off or becomes hard to read, contact your KYMCO dealer for replacements.



(1)

 WARNING	
	Never carry passenger on This carrier. Maximum load : 45 Kg (100 lbs)

(2)

 WARNING

Operating this ATV if you are under the age of 16 increases your chances of severe injury or death.
NEVER operate this ATV if you are under the age of 16.

(3)

CAUTION
Before shifting, you must stop the machine and return the throttle lever to its closed position until the engine speed to the specified idling speed. Otherwise, the transmission may be damaged.

(4)

 WARNING	
	Never carry passenger on This carrier. Maximum load : 85 Kg (187 lbs)

(5)

 **WARNING**

IMPROPER TIRE PRESSURE OR OVERLOADING CAN CAUSE LOSS OF CONTROL. LOSS OF CONTROL CAN RESULT IN SEVERE INJURY OR DEATH.

OPERATING TIRE PRESSURE: Set with tires cold

- **Recommended:**
 - FRONT: $35 \pm 3 \text{ kpa}, (0.35 \pm 0.03 \text{ kgf/cm}^2), 5.0 \pm 0.4 \text{ psi}$
 - REAR : $32 \pm 3 \text{ kpa}, (0.32 \pm 0.03 \text{ kgf/cm}^2), 4.5 \pm 0.4 \text{ psi}$
- **Never set tire pressure over the recommended.**

87505-LFE9-E01

(7)

 **WARNING**

Exceeding vehicle towing limit could lead to an accident. Reduce speed when towing a trailer. Read owner's manual for details.

MAXIMUM TOWING CAPACITY: 150kg (300lbs)

TONGUE WEIGHT: 16kg (35 lbs)

(6)

 **WARNING**

Improper ATV use can result in SEVERE INJURY or DEATH.



ALWAYS USE AN APPROVED HELMET AND PROTECTIVE GEAR



NEVER USE WITH DRUGS OR ALCOHOL

NEVER operate :

- **Without proper training or instruction.**
- **At speeds too fast for your skills or the conditions.**
- **Do not operate the vehicle after consuming ALCOHOL OR DRUGS.**

ALWAYS :

- **Use proper riding techniques to avoid vehicle overturns on hills and rough terrain and in turns.**
- **For your safety, wear gear to include helmet gloves and foot protection.**
- **Gasoline is flammable shut off engine, avoid sparks and open flame when refueling.**

LOCATE AND READ OPERATOR'S MANUAL. FOLLOW ALL INSTRUCTIONS AND WARNINGS



SAFETY INFORMATION

AN ATV IS NOT A TOY AND CAN BE HAZARDOUS TO OPERATE. An ATV handles differently from other vehicles including motorcycles and cars. A collision can occur quickly, even during routine maneuvers, if you fail to take proper pre-cautions.

SEVERE INJURY OR DEATH can result if you do not follow these instructions:

- Read this manual and all labels carefully and follow the operating procedures described.
- Never operate an ATV without proper training or instruction.
Beginners should receive training from a certified instructor.
- Always follow the age recommendation:
 - A child under 16 years old should never operate an ATV with engine size greater than 90cc.
- Never allow a child under age 16 to operate an ATV without adult supervision, and never allow continued use of an ATV by a child if he or she does not have the abilities to operate it safely.
- Never operate an ATV without wearing an approved motorcycle helmet that fits properly. You should also wear eye protection (goggles or face shield), gloves, boots, long-sleeved shirt or jacket, and long pants.

- Never consume alcohol or drugs before or while operating this ATV.
- Never operate at speeds too fast for your skills or the conditions. Always go at a speed that is proper for the terrain, visibility and operating conditions, and your experience.
- Never attempt wheel, jump, or other stunt.
- Always inspect your ATV each time you use it to make sure it is in safe operating condition. Always follow the inspection and maintenance procedures and schedules described in this manual.
- Always keep both hands on the handlebars and both feet on the footboards of the ATV during operation.
- Always go slowly and be extra careful when operating on unfamiliar terrain. Always be alert to changing terrain conditions when operating the ATV.
- Never operate on excessively rough, slippery or loose terrain.
- Always follow proper procedures for turning as described in this manual. Practice turning at low speeds before attempting to turn at faster speeds. Do not turn at excessive speed.
- Never operate the ATV on hills.
- Always follow proper procedures for climbing slopes as described in this manual. Check the terrain carefully before you start up any slope. Shift your weight forward. Never open the throttle suddenly. Never go over the top of a slope at high speed.

- Always follow proper procedures for going down slopes and for braking on slopes as described in this manual. Check the terrain carefully before you start down any slope. Shift your weight backward. Never go down a slope at high speed. Avoid going down slope at an angle that would cause the vehicle to lean sharply to one side. Go straight down the slope where possible.
- Never attempt to turn the ATV around on any slope until you have mastered the turning technique described in this manual on level ground. Avoid crossing the side of a steep slope if possible.
- Always check for obstacles before operating in a new area. Never attempt to operate over large obstacles, such as large rocks or fallen trees. Always follow proper procedures when operating over obstacles as described in this manual.
- Always be careful when skidding or sliding. Learn to safely control skidding or sliding by practicing at low speeds and on level, smooth terrain. On extremely slippery surfaces, such as ice, go slowly and be very cautious in order to reduce the chance of skidding or sliding out of control.
- Never operate an ATV in fast flowing water or in water deeper than that recommended in this manual. Remember that wet brakes may have reduced stopping ability. Test your brakes after leaving water. If necessary, apply them several times to let friction dry out the linings.
- Always use the size and type tires specified in this manual. Always maintain proper tire pressure as described in this manual.
- Never modify an ATV through improper installation or use of accessories.
- Never exceed the stated load capacity for an ATV. Cargo should be properly distributed and securely attached. Reduce speed and follow instructions in this manual for carrying cargo. Allow greater distance for braking.



WARNING

POTENTIAL HAZARD

Improper handling of gasoline.

WHAT CAN HAPPEN

Gasoline can catch fire and you could be burned.

HOW TO AVOID THE HAZARD

Always turn off the engine when refueling.

Do not refuel right after the engine has been running and is still very hot.

Do not spill gasoline on the engine or exhaust pipe/muffler when refueling.

Never refuel while smoking, or while in the vicinity of sparks, open flames, or other sources of ignition such as the pilot lights of water heaters and clothes dryers.

When transporting the machine in another vehicle, be sure it is kept upright and that the fuel cock is in the "OFF" position.

Otherwise, fuel may leak out of the carburetor or fuel tank.

WHAT CAN HAPPEN

Gasoline is poisonous and can cause injuries.

HOW TO AVOID THE HAZARD

If you should swallow some gasoline or inhale a lot of gasoline vapor, or get some gasoline in your eyes, see your doctor immediately.

If gasoline spills on your skin, wash with soap and water. If gasoline spills on your clothing, change your clothes.

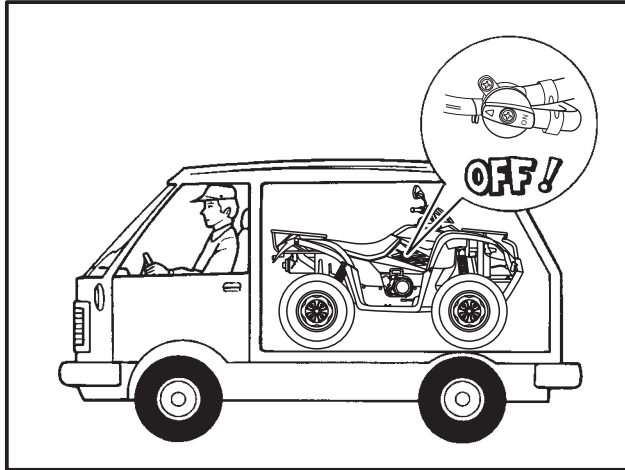

⚠ WARNING

POTENTIAL HAZARD

Starting or running the engine in a closed area.

WHAT CAN HAPPEN

Exhaust fumes are poisonous and may cause loss of consciousness and death within a short time.

HOW TO AVOID THE HAZARD

Always operate your machine in an area with adequate ventilation.

DESCRIPTION AND MACHINE IDENTIFICATION

IDENTIFICATION NUMBER RECORDS

Record the keys identification number, frame serial number and engine serial number information for assistance when order replacement parts.

IGNITION SWITCH KEY NO.

STEERING LOCK KEY NO.

FRAME NO.

ENGINE NO.

KEYS IDENTIFICATION NUMBER

The keys identification number is stamped on the hang tag as shown in the following illustration.

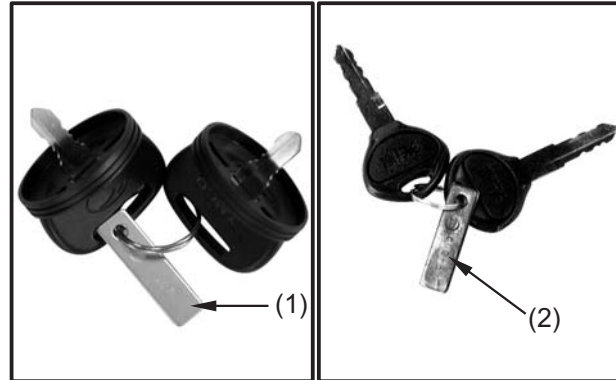

(1) Ignition switch key identification number

(2) Steering lock key identification number

FRAME SERIAL NUMBER

The frame serial number is stamped on the rear of the frame.



(1) Frame serial number

ENGINE SERIAL NUMBER

The engine serial number is stamped on the left crankcase.

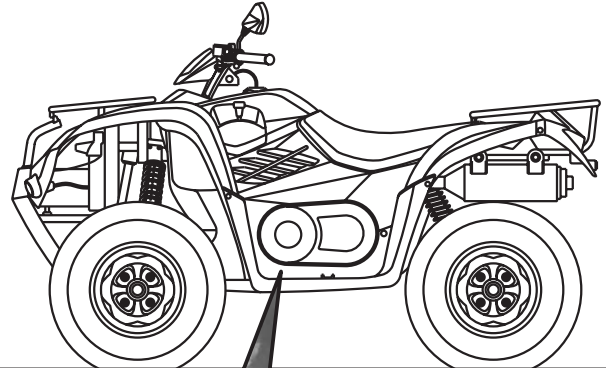

(1) Engine serial number

PARTS LOCATION

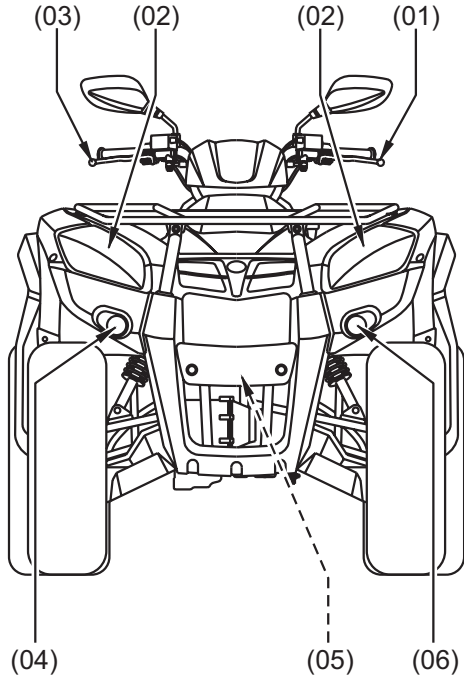

- (01) Rear brake lever
- (02) Headlights/Position lights
- (03) Front brake lever/Front parking brake
- (04) Right front turn signal light
- (05) Steering handlebar lock
- (06) Left front turn signal light
- (A) ATV Winch(LDA0AE version only)





- (07) Right rear turn signal light
- (08) Taillights/Brake lights
- (09) 2WD/4WD select switch and differential lock lever
- (10) Instrument and indicators
- (11) Headlight dimmer switch
 - Starter button
 - Hazard switch
 - Turn signal switch
 - Horn switch
- (12) Left rear turn signal light
- (13) Spark arrester
- (14) Trailer hitch(LDA0AE /LDAOAD(FR)version only)
- (15) License light
- (16) Throttle lever

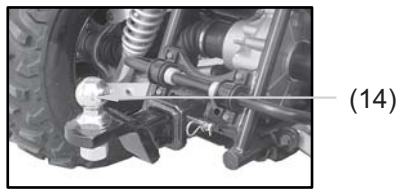



- (17) Reservoir water tank
- (18) Front brake fluid reservoir
- (19) Right rearview mirror
- (20) Seat
- (21) Brake pedal fluid reservoir
- (22) Seat lock lever
- (23) Oil level inspection window
- (24) Tool storage
- (25) Left rearview mirror

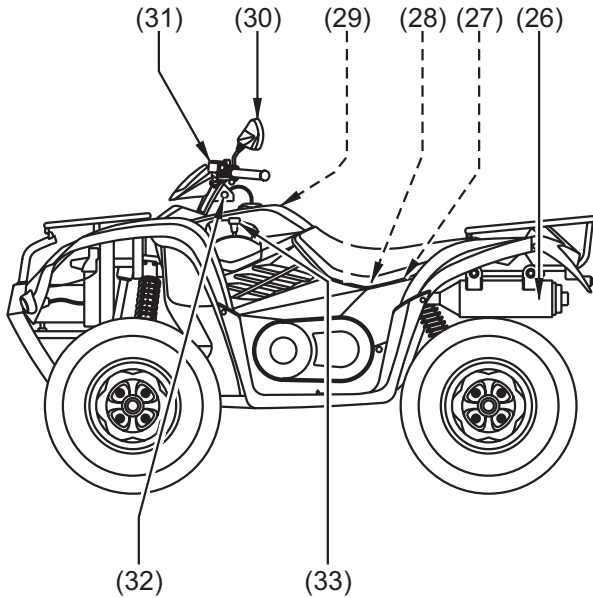

- (26) Exhaust system
- (27) Battery/Fuse
- (28) Tool kit
- (29) Fuel pump
- (30) Left rearview mirror
- (31) Rear brake fluid reservoir
- (32) Accessory socket seat
- (33) Drive select lever

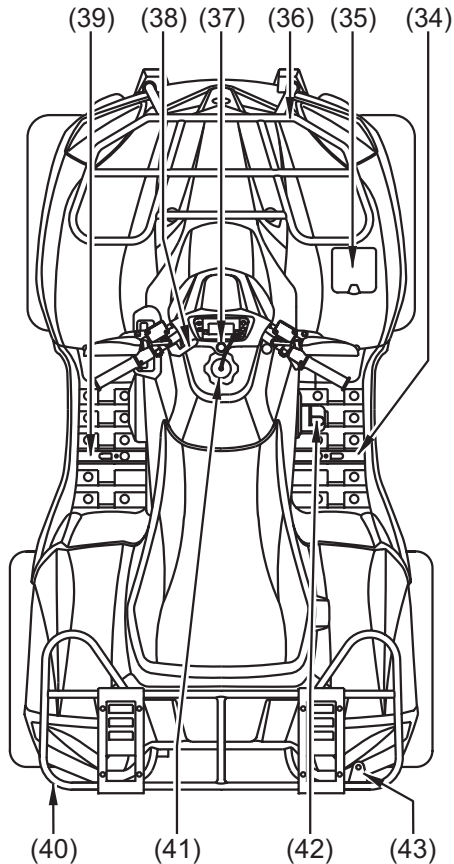

- (34) Right footpeg
- (35) Owner's manual storage
- (36) Front cargo rack
- (37) Ignition switch
- (38) Rear parking brake lever
- (39) Left footpeg
- (40) Rear cargo rack
- (41) Fuel fill cap
- (42) Rear brake pedal
- (43) Flag pole bracket

NOTE:

The machine you have purchased may differ slightly from those shown in the figures of this manual.

CONTROL FUNCTIONS

IGNITION SWITCH

Functions of the respective switch positions are as follows:

OFF:

All electrical circuits are switched off except hazard light. The key can be removed in this position.

ON :

All electrical circuits are switched on.
The engine can be started.
The key can not be removed.

" ":

The ignition switch is ON while the position light and taillight will light.
All electrical circuits are switched on.
The engine can be started.
The key can not be removed.

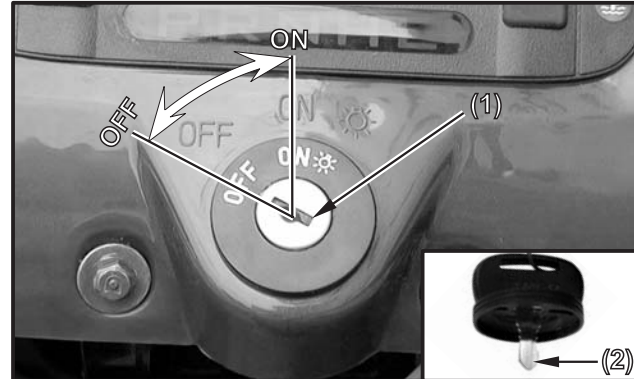

(1) Ignition switch

(2) Key

INSTRUMENTS AND INDICATOR

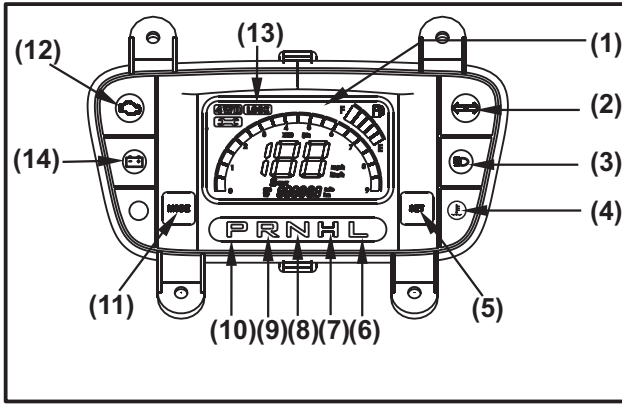

- (1) Multi-function display
- (2) Right turn signal indicator/Left turn signal indicator
- (3) High beam indicator
- (4) Coolant temperature warning indicator
- (5) Set button
- (6) Low-range indicator light "L"
- (7) High-range indicator light "H"
- (8) Neutral indicator light "N"
- (9) Reverse indicator light "N":
- (10) Park indicator light "P"
- (11) Mode button
- (12) EFI system indicator
- (13) Differential lock indicator
- (14) Battery low voltage indicator light

- (1) Multi-function display
The display includes the following functions:
Speedometer
Odometer/Tripmeter
Digital clock
4WD indicator
Fuel gauge
Engine tachometer
- (2) Right turn signal indicator/Left turn signal indicator
Flashes when the right turn signal operates.
- (3) High beam indicator
The ignition switch is at the "⚡" position, the high beam indicator will light when the headlight switch is selected to High beam (≡D).

- (4) Coolant temperature warning indicator
When the coolant temperature reaches a specified level, this indicator comes on to warn that the coolant temperature is too hot. If the indicator comes on during operation, stop the engine as soon as it is safe to do so and allow the engine to cool down for about 10 minutes.
- (5) Set button
This button is used to select ODO, TRIP A and TRIP B.
This button is also used to adjust the time and reset the tripmeter.
- (6) Low-range indicator light “L”
This indicator light comes on when the drive select lever is in the “L” position.
- (7) High-range indicator light “H”
This indicator light comes on when the drive select lever is in the “H” position.
- (8) Neutral indicator light “N”
This indicator light comes on when the drive select lever is in the “N” position.
- (9) Reverse indicator light “R”
This indicator light comes on when the drive select lever is in the “R” position.
- (10) Park indicator light “P”
This indicator light comes on when the drive select lever is in the “P” (park) position.
- (11) Mode button
This button is used to select km/h, mph, km and mile.
This button is also used to adjust the time and reset the trip meter.
- (12) EFI system indicator
Engine check lamp bright or flashes when the EFI system has fails.
- (13) Differential lock indicator
The front axle is equipped with a lockable differential that allows the operator to choose between an open differential or a closed differential in low traction situations. If the differential is in lock manner. The lock indicator will be activated.



Multi-function display

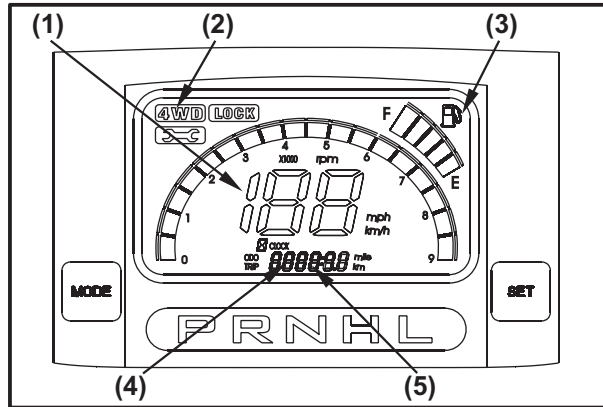

- (1) Speedometer
- (2) 4WD indicator
- (3) Fuel gauge
- (4) Odometer/Tripmeter
- (5) Digital clock

(1) Speedometer

Shows riding speed in km/h or mph.

Press and hold MODE button for more than 2 seconds to select mph or km/h.

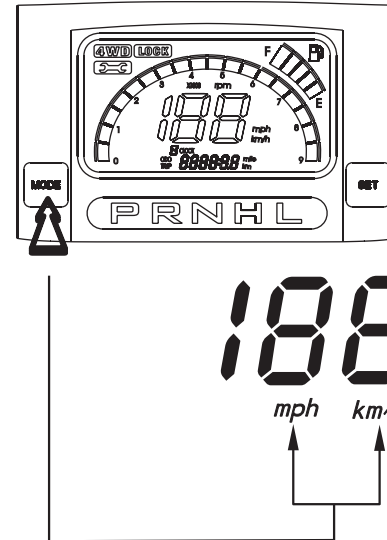

(2) 4WD indicator

Shows the drive mode is in the 4WD.
Shows the drive mode isn't in the 2WD.



(3) Fuel gauge

The fuel gauge shows the approximate fuel supply available in a graduated display. The normal operating fuel range is with the section between the segment F and segment E. When the segment E or the fuel indicator (3) flashes, fuel will be low and you should refill the tank as soon as possible.

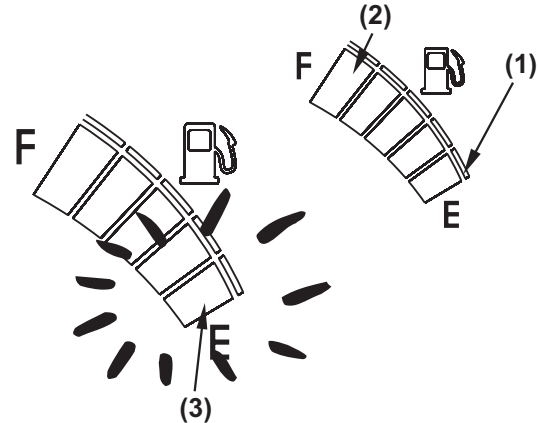

(1) Segment F
(2) Segment E

(3) Fuel indicator

(4) Odometer/Tripmeter

The odometer shows the total mileage in Km or in mph.

The tripmeter shows the trip distance in Km or in mph.

There is tripmeters.

Press and hold SET button for more than 2 seconds to select ODO, TRIP

Press and hold MODE button for more than 2 seconds to select mph or km.

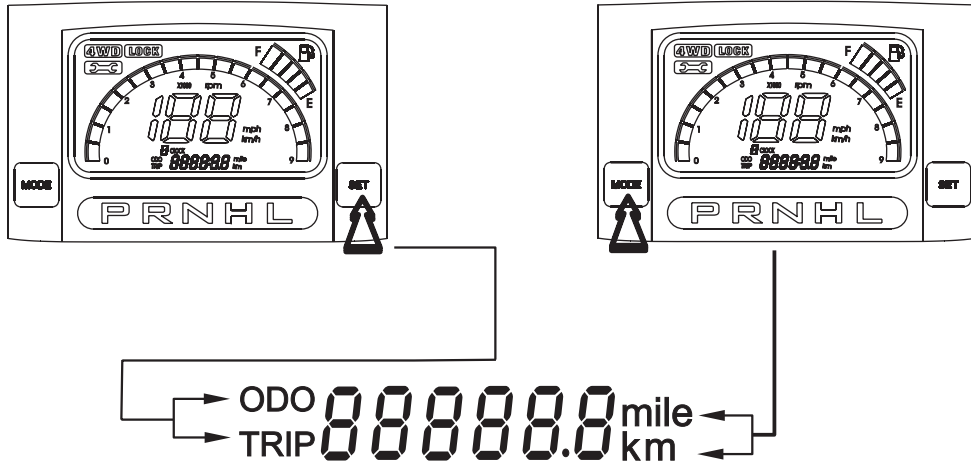

To reset tripmeter:

1. Press and hold SET button for more than 2 seconds to select tripmeter .

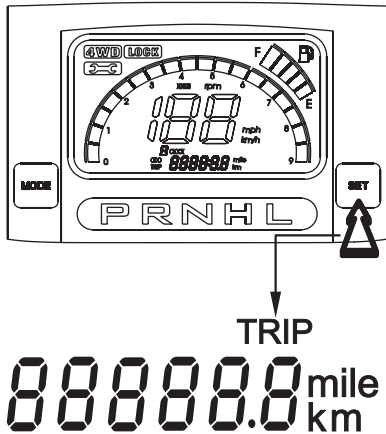

2. Press and hold both the MODE button and SET button in the same time until the tripmeter is reset.

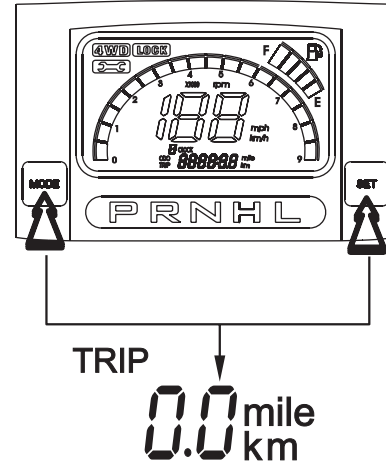

(5) Digital clock

Show the time (hours and minutes) while the ignition is ON.

To adjust the time manually, proceed as follows:

1. Turn the ignition switch ON.
2. Press and hold SET button for more than 2 seconds to select ODO mode.
3. Press and hold both the MODE button and SET button in the same time for more than 2 seconds. The clock will be set in the adjust mode with the hour display flashing.

NOTE:

Digital clock can be adjust in ODO mode only, never select TRIP when you want to adjust your digital clock.

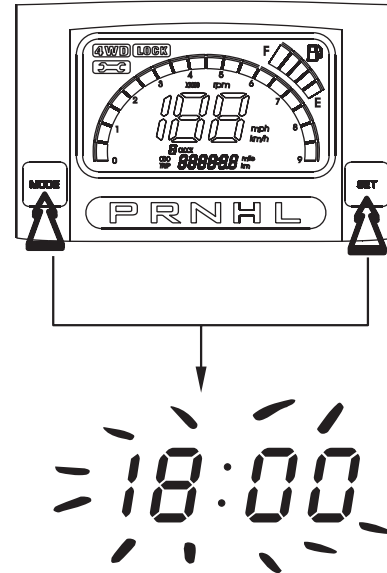

4. To set the hour, press the SET button until the desired hour.

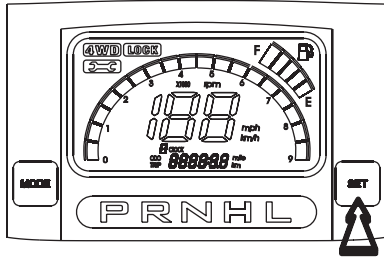

10:00

5. Press the MODE button, the minute display will start flashing.

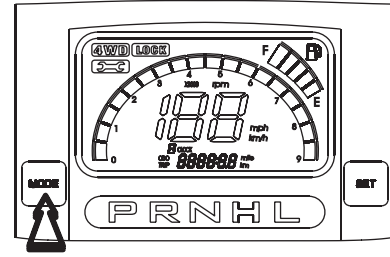

10:00

6. To set minute, press the SET button until the desired minute.

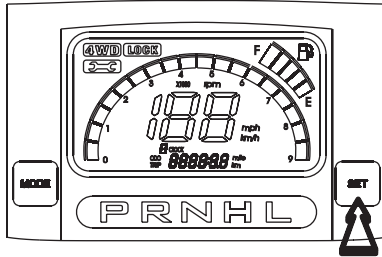

10:30

7. To end the adjustment, Press both the MODE button and SET button in the same time.

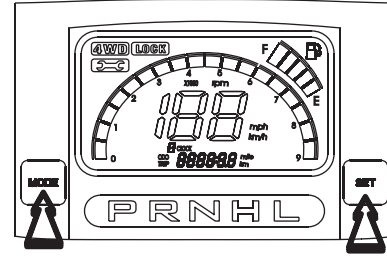

10:30

LEFT HANDLEBAR SWITCHES

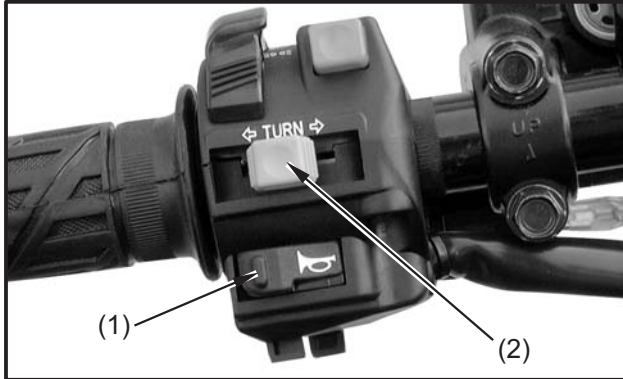

- (1) Horn button
- (2) Turn signal switch

Horn button

When the ignition switch is ON, push the horn button and it will sound.

Turn signal switch

Use the turn signal switch while turning to another direction or shifting to another lane. The turn signal light will flash when the switch is operated and ignition switch is ON.

"←" For turning to the "left".

"→" For turning to the "right".

The instrument turn signal indicator light will also flash when the switch is operated.

Push the switch and it will release.

CAUTION:

- The turn signal light will not release automatically. Be sure to reset it after use; otherwise it may affect the traffic safety.
- The turn signal switch does not work when the ignition switch is "OFF".



(1) Headlight dimmer switch

Headlight dimmer switch

Turn the switch to the "☰D" position to switch on the low beam.

Turn the switch to the "☰D" position to switch on the high beam.

Turn the switch to the "⊘" position to switch off the headlight.

NOTE:

- The headlight can be turned on only when the ignition switch is in the "⊘" position.
- Do not turn on the headlight when the engine is not running because it can drain the battery and without charging in this ATV's electrical system.



(1) Hazard switch

Hazard switch

When the hazard switch is pressed, the right and left turn signal lights flash together. The instrument turn signal indicator light will also flash when the switch is operated.

When the hazard switch is pressed again, the right and left turn signal lights go out together.

CAUTION:

- Turn on this switch when parking or there is a special condition.
- After the hazard switch is turned on, it will not reset automatically. Be sure to reset it after use to avoid affecting the traffic safety.
- When the signal lights are flashing, the hazard switch does not work.
- When the ignition switch is "OFF", the hazard light will still work.



(1) Start switch

Start switch "⚡"

The start switch is used for starting the engine. Pushing the switch in starts the engine.

CAUTION:

See starting instructions prior to starting engine (see page 62 for details).

RIGHT HANDLEBAR SWITCH

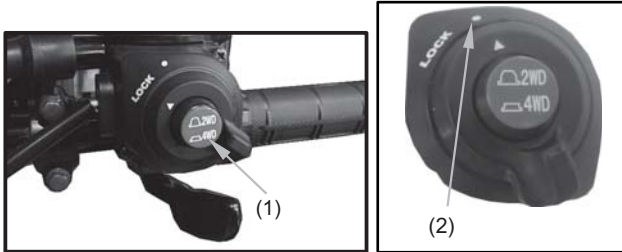

- (1) 2WD/4WD select switch
- (2) Differential lock switch

2WD mode → Without display

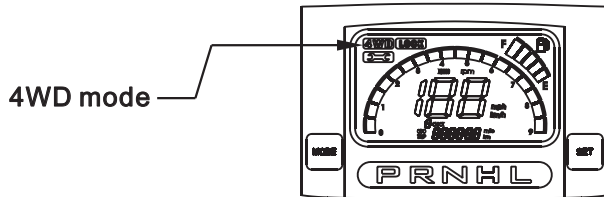

Multi-function display

2WD/4WD select switch

This ATV is equipped with a 2WD/4WD select switch, which permits a choice between the “2WD” and “4WD” drive modes. Select a drive mode that is suitable for your riding.

The 2WD/4WD select switch is located above the throttle lever. To select the drive mode, push the 2WD/4WD select switch to the desired position.

To check your present drive mode, look at the Multi-function display.

Differential lock switch

The Differential lock switch is located above the throttle lever.

The front axle is equipped with a lockable differential that allows the operator to choose between an open differential or a closed differential in low traction situations.

If the differential is in lock manner.

The lock indicator will be activated.

⚠ WARNING

NEVER EXCEED 10 MPH (16 KPH) WHEN DIFFERENTIAL IS LOCKED. LOSS OF CONTROL AND SEVERE INJURY OR DEATH MAY RESULT AT HIGH SPEEDS WHEN DIFFERENTIAL IS LOCKED.

87529-LFE9-M30

TO JUMP START YOUR VEHICLE

1. Remove the seat and locate the batteries.

Find the positive(+) and negative(-) terminals on each battery.

2. Check that the jumper cables do not have loose missing insulation. If they do, you could get a shock. The vehicles could be damaged, too. Before you connect the cables, here are some basic things you should know. Positive(+) will go to positive(+) and negative(-) will go to negative(-) or a metal engine part. Do not connect(+) to (-) or you will get a short that would damage the battery and maybe other parts, too.

3. Connect the red positive(+) cable to the positive(+) terminal of the vehicle with the dead battery. Use a remote positive(+) terminal if the vehicle has one.

4. Don't let the other end touch metal. Connect it to the positive(+) terminal of the good battery. Use a remote positive(+) terminal if the vehicle has one.

5. Now connect the black negative(-) cable to the good battery's negative(-) terminal. Don't let the other end touch anything until the next step. The other end of the negative cable **doesn't** go to the dead battery. It goes to a heavy unpainted metal part on the engine of the vehicle with the dead battery.

6. Now start the vehicle with the good battery and run the engine for a while.

7. Try to start the vehicle with the dead battery. If it won't start after a few tries, it probably needs service.

8. Remove the cables in reverse order to prevent electrical shorting. Take care that they don't touch each other or any other metal.

NOTE:

If the other system isn't a 12-volt system or with a negative ground, both vehicles can be damaged.

THROTTLE LEVER

It is operated by the thumb. Pressing the lever opens the throttle. When pressure is released, spring tension automatically closes the throttle. Regulate the speed of the machine by varying the throttle position.

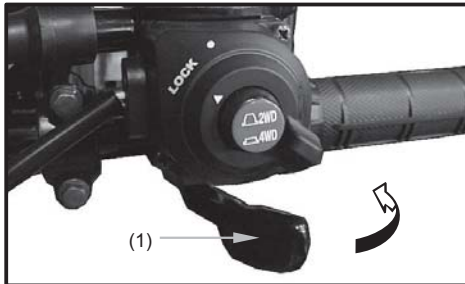

(1) Throttle lever

WARNING

POTENTIAL HAZARD

Malfunction of throttle.

WHAT CAN HAPPEN

The throttle could be hard to operate, making it difficult to speed up or slow down when you need to. This could cause an accident.

HOW TO AVOID THE HAZARD

Check the operation of the throttle lever before you start the engine. If it does not work smoothly, check for the cause.

Correct the problem before riding the ATV. Consult a KYMCO dealer if you can't find or solve the problem yourself.

SPEED LIMITER

The speed limiter keeps the throttle from fully opening, even when the throttle lever is pushed to the maximum. Screwing in the adjuster limits the maximum engine power available and decreases the maximum speed of the ATV.

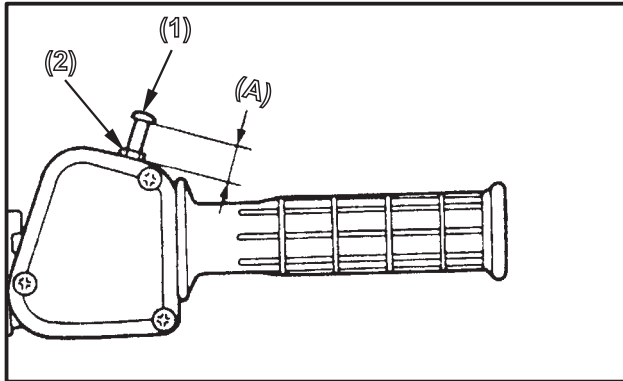

(1) Adjuster (2) Locknut (A) 13mm(0.52in)

WARNING

POTENTIAL HAZARD

Improper adjustment of the speed limiter and throttle.

WHAT CAN HAPPEN

The throttle cable could be damaged. Improper throttle operation could result. You could lose control, have an accident or be injured.

HOW TO AVOID THE HAZARD

Do not turn the speed adjuster out more than 13 mm (0.52 in). Always make sure the throttle lever free play is adjusted to 3~5 mm (0.12~0.2 in). See page 125.

FRONT BRAKE LEVER

The front brake lever is next to the right handgrip.

The front brakes are operated by squeezing the front brake lever.

REAR BRAKE LEVER

The rear brake is operated by squeezing the rear brake lever, near left handgrip.

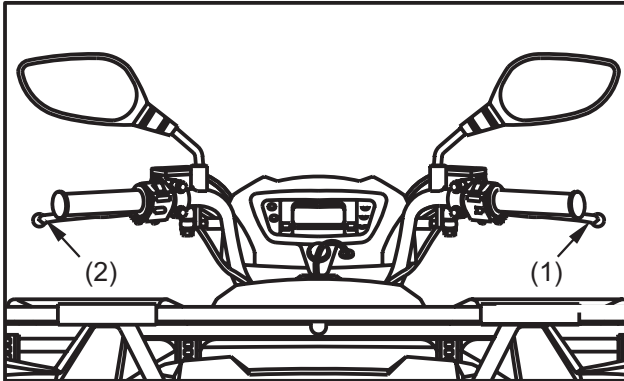

(1) Front brake lever

(2) Rear brake lever

BRAKE PEDAL

This ATV is equipped with a combined brake system. Operating the brake pedal applies the rear brake and a portion of the front brake.

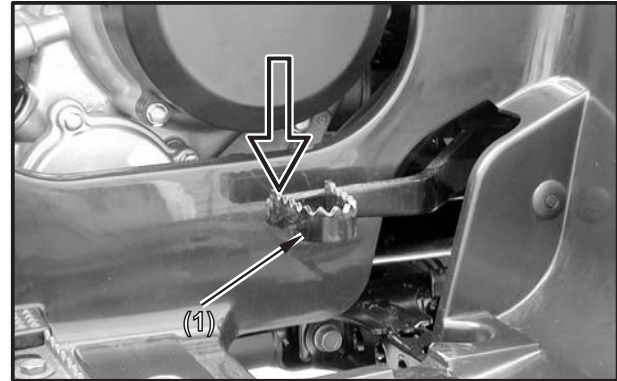

(1) Rear brake pedal

PARKING BRAKE

Front parking brake

To set the front parking brake, squeeze the front brake lever and lock it with the lock lever. Always set the parking brake when parking and before starting the engine.

To unlock the parking brake, squeeze the front brake lever until the lock lever releases.

Using the parking brake in freezing weather may cause the brakes to freeze in the locked position. (See page 70.)

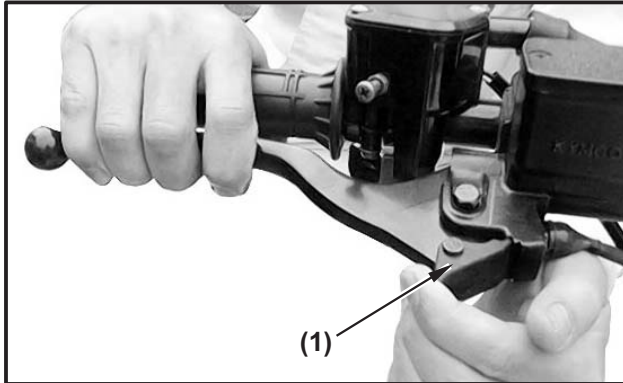

(1) Lock lever

Rear parking brake

To set the rear parking brake, move the lever to position (A).

Always set the parking brake when parking and before starting the engine.

To unlock the rear parking brake, move the lever to position (B).

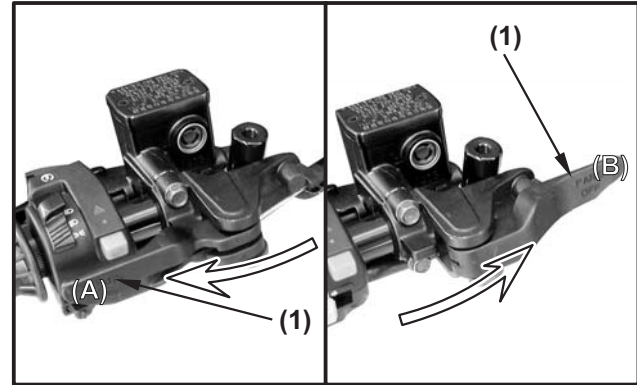

(1) Rear parking brake lever

⚠ WARNING

**Always release the parking brake before riding,
Otherwise will result the vehicle damage.**

⚠ WARNING

POTENTIAL HAZARD

Improper use of the parking brake.

WHAT CAN HAPPEN

The ATV could start moving unexpectedly if the parking brake is not applied before starting the engine. This could cause loss of control or a collision.

The brake could overheat if you ride the ATV without releasing the parking brake. You could lose braking performance which could cause an accident. You could also wear out the brakes prematurely.

HOW TO AVOID THE HAZARD

Always set the parking brake before starting the engine.

Always be sure you have released the parking brake before you begin to ride.

LOCKING STEERING

Turn the steering handlebar left to full and turn the key clockwise, the steering handlebar is locked.

The key can be taken out.

Turn the key counterclockwise, the steering handlebar is released automatically.

The key can be taken out.

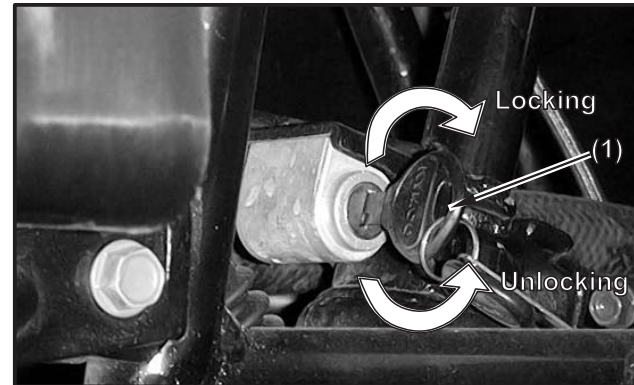

(1) Steering lock key



WARNING

POTENTIAL HAZARD

Improper use of the locking steering.

WHAT CAN HAPPEN

The ATV could cause loss of control or overturn.

HOW TO AVOID THE HAZARD

Always be sure you have released the locking steering handlebar and steering lock key is taken out before you begin to ride.

Never lock the steering handlebar, when the engine is starting.

DRIVE SELECT LEVER

The drive select lever is used to shift your ATV into the low, high, neutral, reverse and park positions. Refer to **page 50 ~ 51** for drive select lever adjustment and operation.

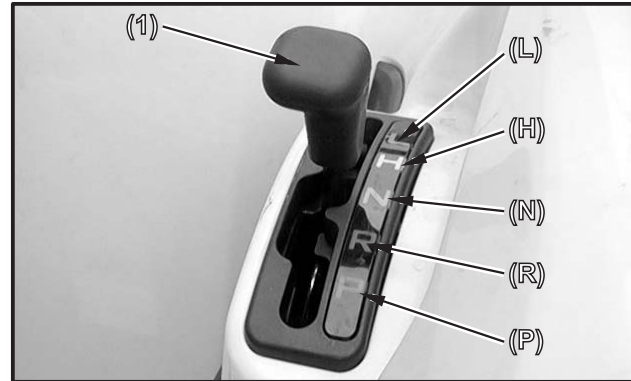

(1) Drive select lever

(N) Neutral

(L) Low

(R) Reverse

(H) High

(P) Park

NOTE:

Apply the rear brake and shift the shift lever into P position before turning off the engine when parking the vehicle on an incline if you park on an incline with shift lever in H, L or R position, vehicle weight will make it difficult to shift into neutral.

FUEL TANK CAP

After refueling, be sure to tighten the fuel tank cap until it clicks.

Insert the breather tube into the meter cover hole.

To refuel refer to **page 53**.

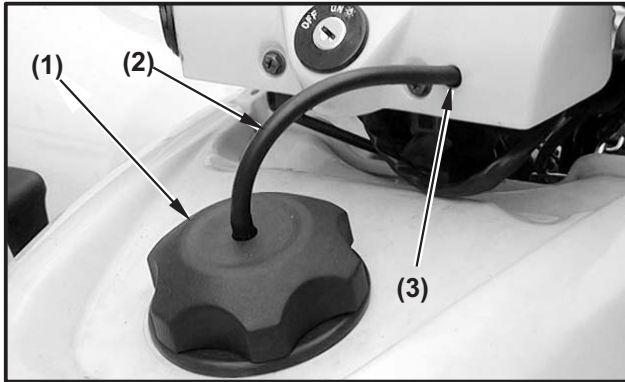

(1) Fuel tank cap

(2) Breather tube

(3) Meter cover hole

FUEL SYSTEM

Engine would not start acceleration

Intake air leak

Fuel contaminated/deteriorated

Pinched or clogged fuel hose

Faulty fuel pump

FUEL SYSTEM

Engine stall, hard to start, rough idling

Intake air leak

Fuel contaminated/deteriorated

Pinched or clogged fuel hose

Idle speed misadjustment

Fail to perform TPS/ISC reset

FUEL SYSTEM

Poor performance (drive ability) and poor fuel economy

Pinched or clogged fuel hose

faulty injector

SPARK PLUG INSPECTION

If the plug is oily or has carbon built up it, have it cleaned, preferably in a sand-blasting device, and then clean off any abrasive particles. The plug may also be to other suitable tool.

If the insulator is cracked, replace the plug.
Use the standard plug.

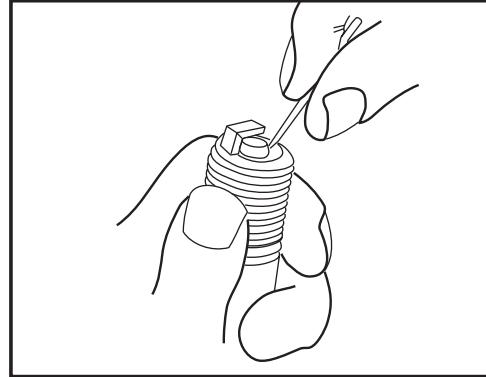

Battery Inspection

Checking the battery voltage if the cold engine start-ambient temperature below -18°C (0°F).

Refer to "starting a cold engine" for proper operation. (See page 62.)



SEAT

To remove the seat, pull the seat lock lever upward and pull up the seat at the rear.

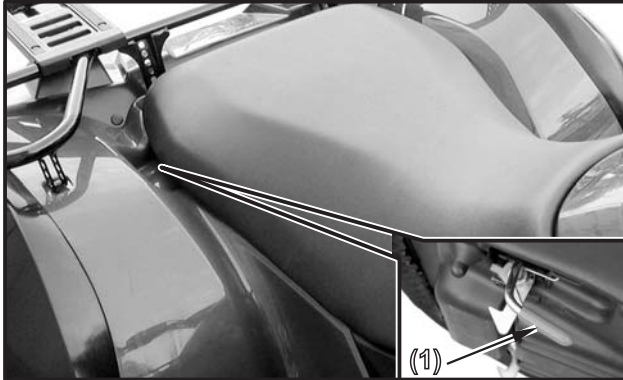

(1) Seat lock lever

To install the seat, align the tabs on the seat with the grommets on the frame and press the seat down until it locks.

NOTE:

Make sure that the seat is securely fitted.



FLAG POLE BRACKET

Flag poles are optional equipment available from your KYMCO dealer. To mount a flag pole in the bracket to make you more visible.

NOTE:

Flag poles are required in some riding areas. Check local regulations before riding.

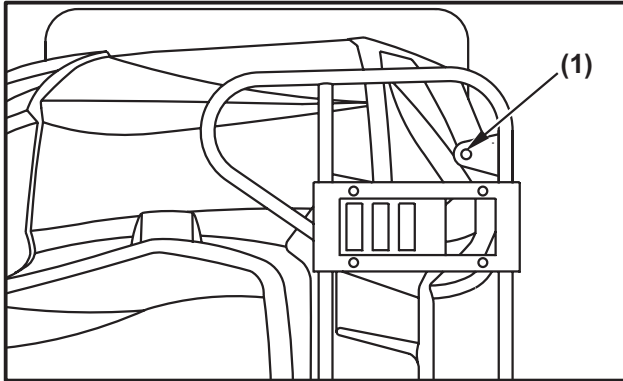

(1) Flag pole bracket

TRAILER HITCH

The trailer hitch is located on the rear axle housing. To use the hitch, you will need proper size ball as specified by the trailer manufacturer.

To attach the ball and properly hook up a trailer, follow the trailer manufacturer's instructions. For load limits and operational guidelines, see **page 84**.

(1) Trailer(LDA0AE/LDA0AD(FR) Version only)

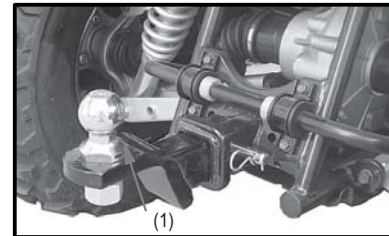

OWNER'S MANUAL STORAGE COMPARTMENT

Your ATV provides storage for the owner's manual so you'll have it with you for easy reference. Store your owner's manual (1) in the storage compartment (2) at the right side of the front fender.

To open the compartment, remove the lid (3). The owner's manual should be stored in the plastic bag.

Be careful not to flood this area when washing your ATV



- (1) Owner's manual
- (2) Storage compartment

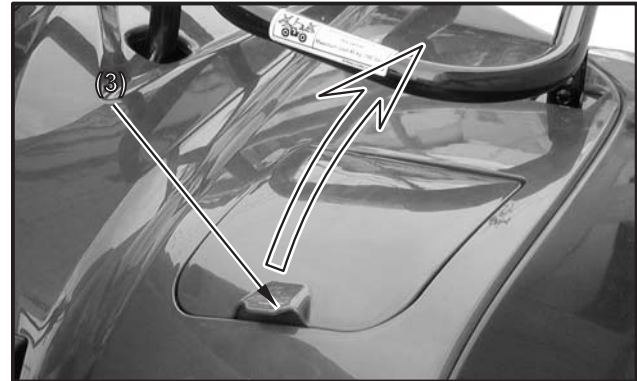

- (3) Lid

ACCESSORY SOCKET

The accessory socket (1) is attached to the left side of the meter cover. You can use the accessory socket to power a trouble light, spotlight, radio, or cell phone, etc.

CAUTION:

- Do not plug in any heat-generating accessory such as an automobile cigarette lighter because it can damage the socket.
- Be careful not to flood this accessory socket when washing your ATV.

To use the accessory socket:

1. Turn the ignition switch ON, then start the engine.
2. Turn the headlights OFF.
3. Open the accessory socket cap (2), and then insert the accessory power plug into the socket.

Be sure the engine is on and the headlights are turned off before using the accessory socket, otherwise you may drain the battery.

The accessory socket's rated capacity is DC 12V, 120 Watts (10A) or less. If you exceed this limit, you may blow a fuse.

When you are done using an accessory, unplug it, and cover the socket with the cap.



(1) Accessory socket

(2) Cap

PRE-OPERATION CHECKS

Before using this machine, check the following points:

ITEM	ROUTINE	PAGE
DRIVE SELECT LEVER	<ul style="list-style-type: none"> • Check the lever for proper operation. 	48 ~ 51
BRAKE	<ul style="list-style-type: none"> • Check operation, condition, and brake fluid level. • Fill with DOT 4 brake fluid if necessary. 	52, 126 ~ 128
FUEL	<ul style="list-style-type: none"> • Check fuel level. • Fill with fuel if necessary. 	53 ~ 54
ENGINE OIL, FINAL GEAR, DIFFERENTIAL GEAR OIL	<ul style="list-style-type: none"> • Check oil level. • Fill with oil if necessary. • Check for leakage 	55 ~ 56, 106 ~ 116
DRIVE SHAFT BOOTS	<ul style="list-style-type: none"> • Check for damage. 	54
THROTTLE	<ul style="list-style-type: none"> • Check for proper throttle cable operation. 	57
WHEELS AND TIRES	<ul style="list-style-type: none"> • Check tire pressure, wear and damage. 	58 ~ 60, 132 ~ 133
FITTINGS AND FASTENERS	<ul style="list-style-type: none"> • Check all fitting and fasteners. 	57
SWITCHES	<ul style="list-style-type: none"> • Check for proper function. 	57
LIGHTS	<ul style="list-style-type: none"> • Check for proper operation. 	57, 137
COOLANT	<ul style="list-style-type: none"> • Check coolant leakage. • Fill with coolant if necessary. 	60 ~ 61, 129 ~ 131



WARNING

POTENTIAL HAZARD

**Failure to inspect the ATV before operating.
Failure to properly maintain the ATV.**

WHAT CAN HAPPEN

**Increases the possibility of an accident or
equipment damage.**

HOW TO AVOID THE HAZARD

**Always inspect your ATV each time you use
it to make sure the ATV is in safe operating
condition.**

**Always follow the inspection and
maintenance procedures and schedules
described in the Owner's Manual.**

DRIVE SELECT LEVER

CAUTION:

**Before shifting, you must stop the machine
and return the throttle lever to its closed
position until the engine speed to the
specified idling speed. Otherwise, the
transmission may be damaged.**

Check operation of the lever before start the engine.

1. Make sure moving the shift lever into the "N" position of the shift guide.
2. Turn the ignition switch to "ON" and check the neutral indicator lamp comes on.
3. If the neutral indicator lamp does not come on, then see **page 50~51** for adjustment.

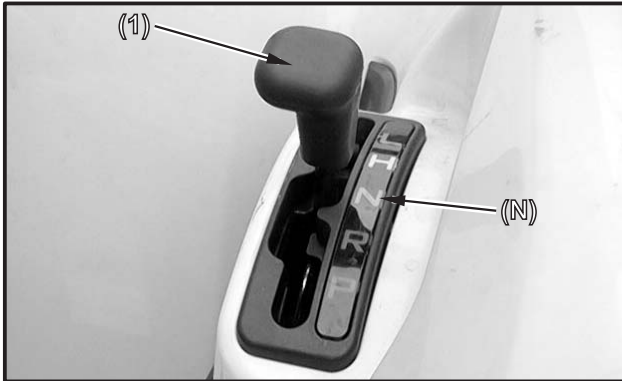

(1) Drive select lever

(N) Neutral

WARNING

POTENTIAL HAZARD

Operating with improperly adjusted drive select lever.

WHAT CAN HAPPEN

You may lose control of the gear shifting, which lead to accident.

HOW TO AVOID THE HAZARD

Make sure moving the shift lever into the "N" position and neutral indicator lamp comes on before start the engine.

Drive select lever adjustment

1. Turn the ignition switch is ON and make sure the engine stop.
2. Remove 3 fasteners (1), then remove the left side cover (2).

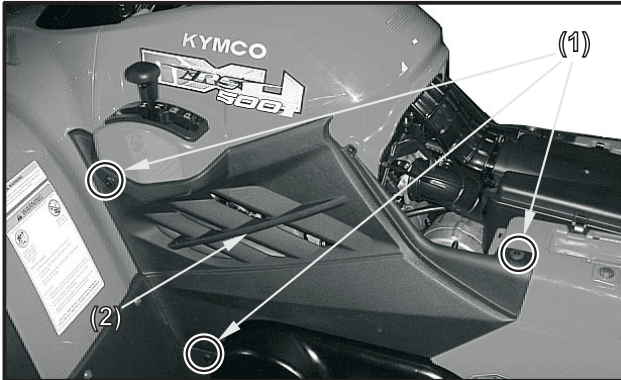

- (1) Fasteners
(2) Left side cover

3. Loosen the locknuts (3) of rod (4). Shift the gear to neutral by moving the shift lever and/or turn the rod. (The neutral indicator lamp comes on.)

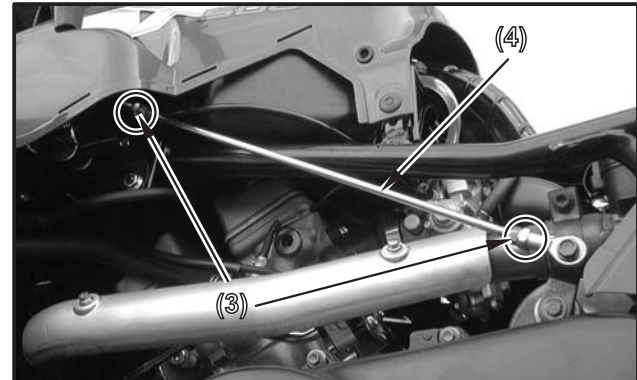

- (3) Lock nuts
(4) Rod

4. Turn the rod clockwise or counterclockwise until the drive select lever (5) into the "N" position of the shift guide and tighten the locknuts.

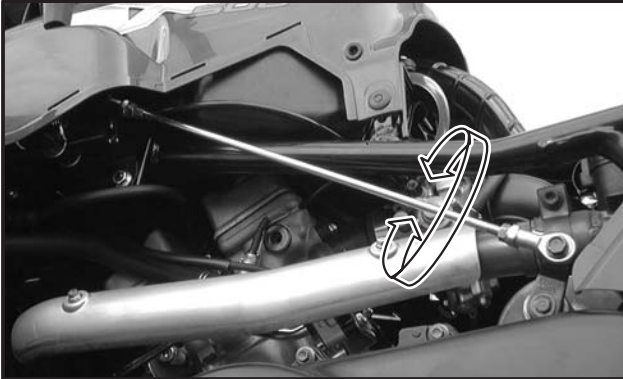

(5) Drive select lever
(N) Neutral

FRONT AND REAR BRAKES

1. Make sure there is no brake fluid leakage.
2. Check operation of the levers and pedal.
They should move smoothly and there should be a firm feeling when the brake is applied. If not, have the machine inspected by a KYMCO dealer.
3. Brake operation
Test the brakes at slow speed after starting out to make sure they are working properly. If the brakes do not provide proper braking performance, inspect the brakes for wear.
(See page 126~128.)

WARNING

POTENTIAL HAZARD

Riding with improperly operating brakes.

WHAT CAN HAPPEN

You could lose braking ability, which could lead to an accident.

HOW TO AVOID THE HAZARD

Always check the brakes at the start of every ride. Do not ride the ATV if you find any problem with the brakes. If a problem cannot be corrected by the adjustment procedures provided in this manual, have the ATV inspected by a KYMCO dealer.

FUEL

Fill the fuel tank when necessary and make sure there is sufficient gasoline in the tank.

Check for leaks.

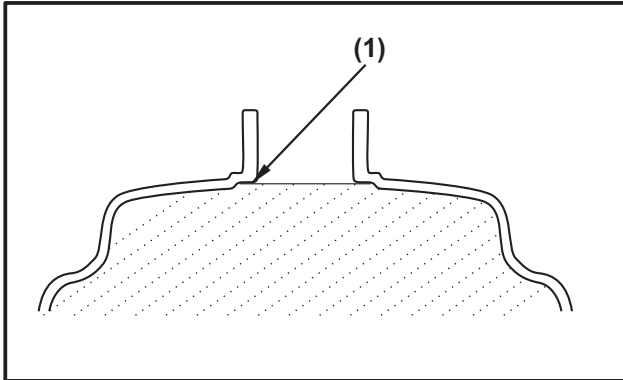

(1) Fuel neck

Recommended fuel:

UNLEADED FUEL

Fuel tank capacity:

Total: 16 L(3.36 Imp gal, 4.16 US gal)

Reserve : 2.3 L(0.48 Imp gal, 0.6 US gal)

Your KYMCO engine has been designed to use regular unleaded gasoline with a pump octane number of 86 or higher, or research octane number of 91 or higher. If knocking or pinging occurs, use a different brand of gasoline or premium unleaded fuel. Unleaded fuel will give you longer spark plug life and reduced maintenance cost.

Use unleaded fuel only because it produces fewer engine and spark plug deposits and extends the life of the exhaust system. Never use stale or contaminated gasoline or an oil/gasoline mixture.

Avoid getting dirt, dust or water in the fuel tank.

⚠ WARNING

POTENTIAL HAZARD

Improper care when refueling.

WHAT CAN HAPPEN

Fuel can spill, which can cause a fire and severe injury.

Fuel expands when it heats up. If the fuel tank is overfilled, fuel could spill out due to heat from the engine.

HOW TO AVOID THE HAZARD

Do not overfill the fuel tank. Be careful not to spill fuel, especially on the engine or exhaust pipe. Wipe up any spilled fuel immediately. Be sure the fuel tank cap is closed securely.

Do not refuel right after the engine has been running and is still very hot.

DRIVE SHAFT BOOTS

Check the rubber drive shaft boots for damage or leaking grease. If necessary, have your KYMCO dealer replace them.

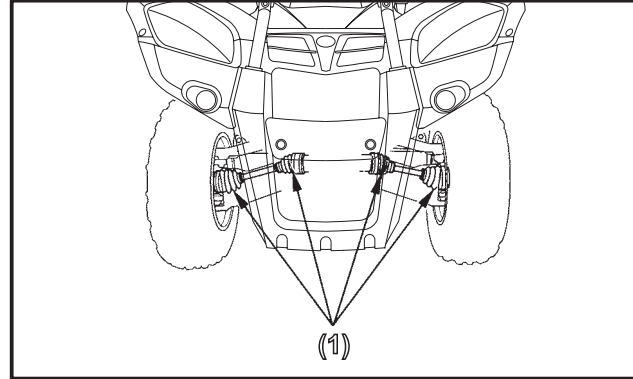

(1) Drive shaft boots

ENGINE OIL

Make sure the engine oil at the specified level.
Add oil as necessary. (See page 106~112.)
Check for leaks.

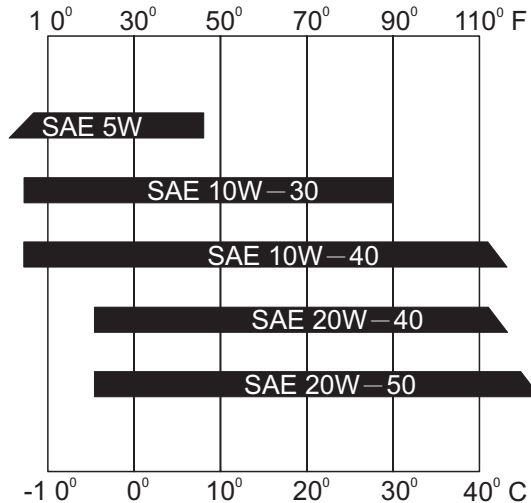

Recommended engine oil classification: API
Service SJ type or higher

CAUTION:

Be sure to use motor oils that do not contain anti-friction modifiers. Passenger car motor oils (often labeled "Energy Conserving") contain anti-friction additives which will cause starter clutch slippage, resulting in reduced component life and poor engine performance.

Oil quantity:

Engine oil:

Periodic oil change:

3 L (2.64 Imp qt, 3.18 US qt)

After draining and oil filter cartridge change:

3.2 L (2.82 Imp qt, 3.39 US qt)

Total amount:

3.6 L (3.17 Imp qt, 3.82 US qt)

REAR GEAR CASE OIL

Make sure the rear gear case oil at the specified level. Add oil as necessary. **(See page 113~114.)**

Check for leaks.

Recommended rear gear case oil:

Type: hypoid gear oil

Viscosity: SAE# 80

FRONT GEAR CASE OIL

Make sure the front gear case oil at the specified level. Add oil as necessary. **(See page 115~116.)**

Check for leaks.

Recommended final gear oil:

Type: hypoid gear oil

Viscosity: SAE #80

Oil quantity:

Rear gear case oil:

Periodic oil change:

0.23 L (0.20 Imp qt, 0.243 US qt)

Total amount:

0.25 L (0.22 Imp qt, 0.265 US qt)

Oil quantity:

Front gear case oil:

Periodic oil change:

0.25 L (0.22 Imp qt, 0.265 US qt)

Total amount:

0.27 L (0.238 Imp qt, 0.286 US qt)

THROTTLE LEVER

Check to see that the throttle lever operates correctly. It must open smoothly and spring back to idle position when released. Repair as necessary for proper operation.

FITTINGS AND FASTENERS

Always check the tightness of chassis fittings and fasteners before a ride. Take the machine to a KYMCO dealer or refer to the Service Manual for correct tightening torque.

LIGHTS

Check the headlight and taillight to make sure they are in working condition. Repair as necessary for proper operation.

SWITCHES

Check the operation of the headlight switch, engine stop switch and any other switches. Repair as necessary for proper operation.

TIRES



WARNING

POTENTIAL HAZARD

Operating this ATV with improper tires, or with improper or uneven tire pressure.

WHAT CAN HAPPEN

Use of improper tires on this ATV, or operation of this ATV with improper or uneven tire pressure, may cause loss of control, increasing your risk of accident.

HOW TO AVOID THE HAZARD

1. The tires listed below have been approved by Kwang Yang Motor Co., Ltd. for this model. Other tire combinations are not recommended.

	Size	Type
Front	25X8-12	Tubeless
Rear	25X10-12	Tubeless

2. The tires should be set to the recommended pressure:

• Recommended tire pressure

Front: 32~38 kpa (0.32~0.38 kgf/cm²,
4.6~5.4 psi)

Rear: 29~35 kpa (0.29~0.35 kgf/cm²,
4.1~4.9 psi)

- Check and adjust tire pressures when the tires are cold.
- Tire pressures must be equal on both sides.

3. Tire pressure below the minimum specified could cause the tire to dislodge from the rim under severe riding conditions.

The following are minimums:

Front: 32 kpa (0.32 kgf/cm², 4.6 psi)

Rear: 29 kpa (0.29 kgf/cm², 4.1 psi)

4. Higher pressures may cause the tire to burst. Inflate the tires very slowly and carefully. Fast inflation could cause the tire to burst.

Set pressure tires cold.

Set tire pressures to the following

M X U 500i IRS	Recommended pressure	Minimum	Maximum
Front	35 kpa (0.35 kgf/cm ² , 5.0 psi)	32 kpa (0.32 kgf/cm ² , 4.6 psi)	38 kpa (0.38 kgf/cm ² , 5.4 psi)
Rear	32 kpa (0.32 kgf/cm ² , 4.5 psi)	29 kpa (0.29 kgf/cm ² , 4.1 psi)	35 kpa (0.35 kgf/cm ² , 4.9 psi)

How to measure tire pressure

Use the low-pressure tire gauge. (Tool kit)

NOTE:

The low-pressure tire gauge is included as standard equipment. Make two measurements of the tire pressure and use the second reading. Dust or dirt in the gauge could cause the first reading to be incorrect.

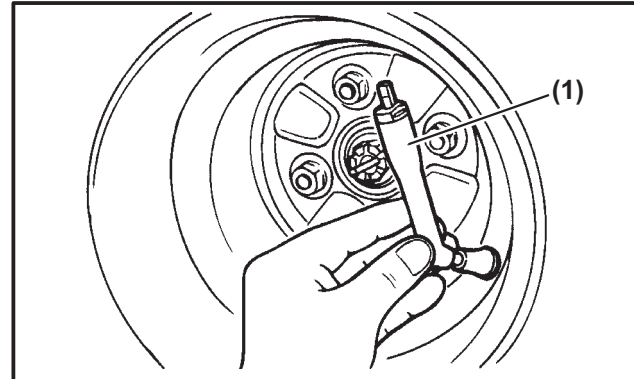

(1) Low-pressure tire gauge

Tire wear limit

When the tire groove decreases to 4 mm (0.16 in) due to wear, replace the tire.

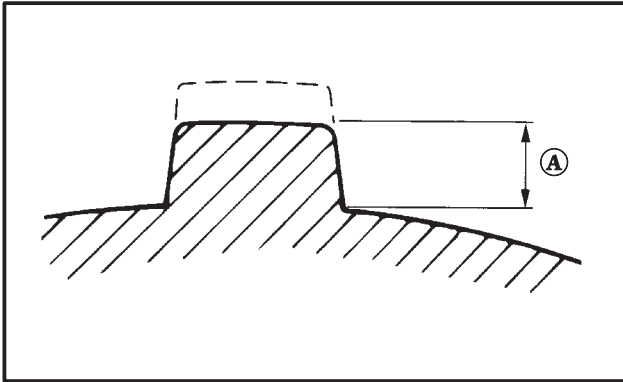

A. Standard: 4 mm (0.16 in)

COOLANT

Check the coolant level in the reservoir tank when the engine is cold. (The coolant level will vary with engine temperature.) The coolant level is satisfactory if it is between the "FULL" and "LOW" marks on the tank. If the coolant level is at or below the "LOW" level, add tap water (soft water) to bring the level up to "FULL". Change the coolant every two years. (See page 129~131 for details.)

CAUTION:

Hard water or salt water is harmful to the engine. You may use distilled water if you can not get soft water.

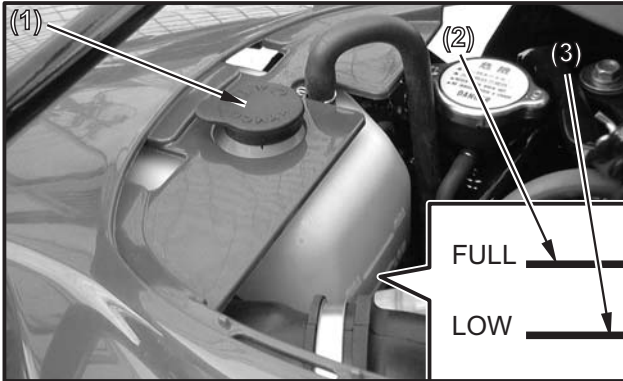

- (1) Coolant reservoir cap
- (2) Maximum level mark
- (3) Minimum level mark

WARNING

POTENTIAL HAZARD

Removing the radiator cap when the engine and radiator are still hot.

WHAT CAN HAPPEN

You could be burned by hot fluid and steam blown out under pressure.

HOW TO AVOID THE HAZARD

Wait for the engine to cool before removing the radiator cap. Always use a thick rag over the cap. Allow any remaining pressure to escape before completely removing the cap.

Should be serviced by your authorized KYMCO dealer when changing the coolant.

OPERATION

WARNING

POTENTIAL HAZARD

Operating ATV without being familiar with all controls.

WHAT CAN HAPPEN

Loss of control, which could cause an accident or injury.

HOW TO AVOID THE HAZARD

Read the Owner's Manual carefully. If there is a control or function you do not understand, ask your KYMCO dealer.

STARTING A COLD ENGINE

WARNING

POTENTIAL HAZARD

Freezing control cables in cold weather.

WHAT CAN HAPPEN

You could be unable to control the ATV, which could lead to an accident or collision.

HOW TO AVOID THE HAZARD

When riding in cold weather, always make sure all control cables work smoothly before you begin riding.

1. Set the parking brake and unlock the steering (take steering lock key out).
2. Turn the fuel valve to "ON".
3. Turn the ignition switch to "ON".
4. Shift the drive select lever into the neutral or park position.

5. Checking the battery voltage if the cold engine start-ambient temperature below -18°C (0°F).

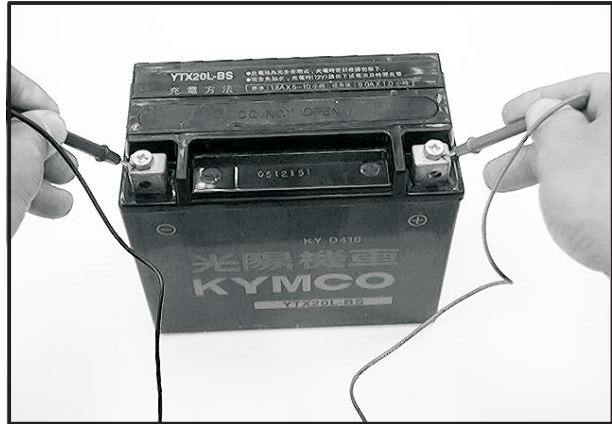

NOTE:

- The engine can be started in any gear if the brake lever is applied. However, it is recommended to shift into neutral or park before starting the engine.
- When the select lever is in the neutral or park position, if either indicator light does not come on, ask a KYMCO dealer to inspect its electric circuit.

6. Completely close the throttle lever and start the engine by pushing the start switch.

NOTE:

- If the engine fails to start, release the start switch, then push the start switch again. Each cranking should be as short as possible to preserve battery energy. Do not crank the engine more than 10 seconds on each attempt.
- If the battery is discharged, Changing new one to start the engine.
- Spark plug inspection

**WARNING**

To avoid damage from the vehicle's electronic fuel injection system, do not remove or install a battery wire when the ignition switch is at the "ON" position.

NOTE:

Do not allow water enter the right case.

CAUTION:

See the "engine break-in" section prior to operating engine for the first time.

STARTING A WARM ENGINE

To start a warm engine, refer to the "Starting a cold engine" section. The throttle should be opened slightly.

WARMING UP

To get maximum engine life, always warm up the engine before starting off. Never accelerate hard with a cold engine! To see whether or not the engine is warm, check if it responds to the throttle normally.

DRIVE SELECT LEVER OPERATION AND REVERSE DRIVING

CAUTION:

Before shifting, you must stop the machine and return the throttle lever to its closed position until the engine speed to the specified idling speed. Otherwise, the transmission may be damaged.

NOTE:

Apply the rear brake and shift the shift lever into P position before turning off the engine when parking the vehicle on an incline if you park on an incline with shift lever in H, L or R position, vehicle weight will make it difficult to shift into neutral.

Shifting: Neutral to high and high to low

1. Bring the ATV to a complete stop and return the throttle lever to the closed position.
2. Apply the brakes, then shift by moving the drive select lever along the shift guide.

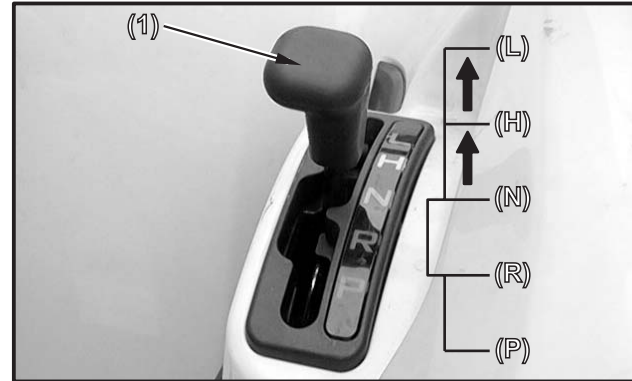

(1) Drive select lever

(H) High

(R) Reverse

(L) Low

(N) Neutral

(P) Park

NOTE:

Make sure that the drive select lever is completely shifted into position.

Shifting: neutral to reverse and reverse to park

1. Bring the machine to a complete stop and return the throttle lever to the closed position.
2. Apply the brake pedal.
3. Shift from neutral to reverse or from reverse to park and vice versa by moving the drive select lever along the shift guide.

NOTE:

When in reverse, the reverse indicator light should be on. If the light does not come on, ask a KYMCO dealer to inspect the machine.

4. Check behind for people or obstacles, then release the rear brake pedal.
5. Open the throttle lever gradually and continue to watch to the rear while backing.

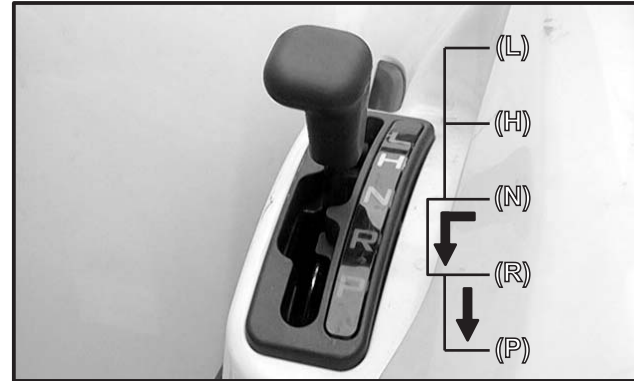

WARNING

POTENTIAL HAZARD

Improperly operation in reverse.

WHAT CAN HAPPEN

You could hit an obstacle or person behind you, resulting in serious injury.

HOW TO AVOID THE HAZARD

When you shift into reverse, make sure there are no obstacles or people behind you. When it is safe to proceed, go slowly.

ENGINE BREAK-IN

There is never a more important period in the life of your machine than the period between zero and 20 hours.

For this reason, we ask that you carefully read the following material. Because the engine is brand new, you must not put an excessive load on it for the first 20 hours, the various parts in the engine wear and polish themselves to the correct operating clearances.

During this period, prolonged full throttle operation or any condition which might result in excessive engine heating must be avoided.

However, momentary (2~3 seconds maximum) full throttle operation under load does not harm the engine.

Each full throttle acceleration sequence should be followed with a substantial rest period for the engine by cruising at lower r/min so the engine can rid itself of the temporary build up of heat.

If any abnormality is noticed during this period, consult a KYMCO dealer.

1. 0~10 hours:

Avoid continuous operation above half throttle. Allow a cooling off period of five to ten minutes after every hour of operation. Vary the speed of the machine from time to time. Do not operate it at full throttle position.

2. 10~20 hours:

Avoid prolonged operation above 3/4 throttle. Rev the machine freely through the gears but do not use full throttle at any time.

3. After break-in

Avoid prolonged full throttle operation. Vary speeds occasionally.

PARKING

When parking, stop the engine and shift into the park position. Turn the fuel valve to "OFF" and apply the parking brake.

The front brake lever has three locked position that allow it to be used as a parking brake.

To set the front parking brake, **see page 36**.

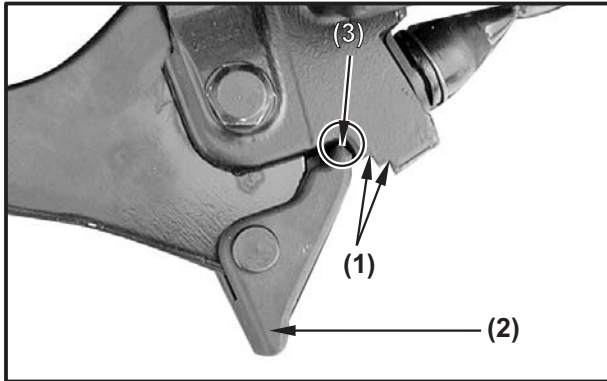

- (1) Locked position
- (2) Lock lever
- (3) Certainly locked position

To set the rear parking brake, **see page 36**.

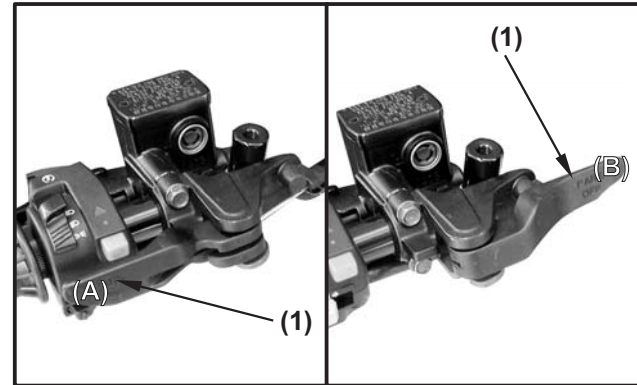

- (1) Rear parking brake lever
- (A) Lock position
- (B) Unlock position

Parking on a slope



WARNING

POTENTIAL HAZARD

Parking on a slope or other incline.

WHAT CAN HAPPEN

The ATV could roll out of control, increasing the chance of an accident.

HOW TO AVOID THE HAZARD

Avoid parking on slope or other inclines. If you must park on an incline, place the machine transversely across the incline, apply the parking brake, and block the front and rear wheels with rocks or other objects. Do not park the ATV at all on slope that are so steep you could not walk up them easily.

1. Bring the machine to a stop by applying the brakes.
2. Stop the engine.
3. With the brake applied, shift the drive select lever into the park position
4. Apply the parking brake.

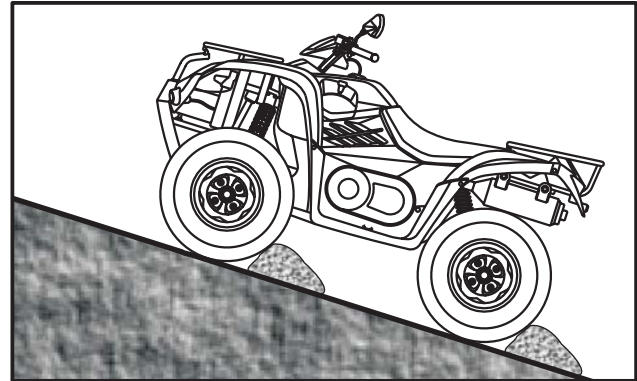

ACCESSORIES

Accessories can affect the handling and control of your ATV. Keep the following in mind when considering an accessory or operating an ATV which has accessories.

- Choose only accessories designed for your ATV. Your KYMCO dealer has a variety of genuine KYMCO accessories. Other accessories may also be available on the market. However, it is not possible for KYMCO to test all non-KYMCO accessories, nor have any control over the quality or suitability of them. Choose a genuine KYMCO accessory, or one that is equivalent in design and quality.
- Accessories should be rigidly and securely mounted. An accessory which can shift position or come off while you are riding could affect your ability to control the ATV.
- Do not mount an accessory where it could interfere with your ability your to control the ATV. Examples include (but are not limited to) a heavy or bulky object attached to the handlebars which could make steering difficult, an accessory that limits your ability to move around on the seat, or one that limits your view.
- Use extra caution when riding an ATV with accessories. The ATV may handle differently than it does without accessories.

LOADING

As originally equipped, this ATV can carry cargo or tow a trailer, you must use common sense and good judgment. Keep the following points in mind:

- Never exceed the weight limit shown. An overloaded ATV can be unstable.
- **Maximum load**
Rear cargo rack: 85 kg (187 lbs)
Front cargo rack: 45 kg (100 lbs)
- **Trailer:**
Maximum towing capacity: 150 kg (330 lbs)
Tongue weight: 16kg (35 lbs)

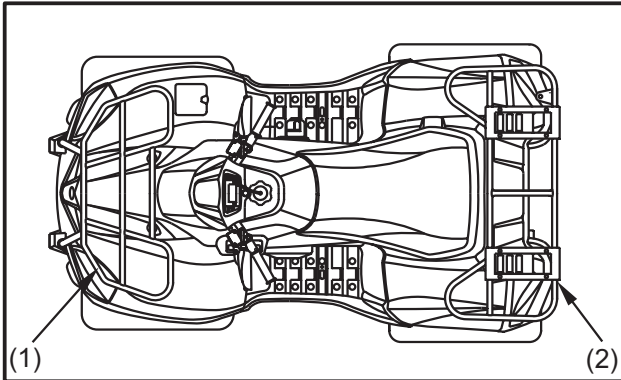

(1) Front cargo rack

(2) Rear cargo rack

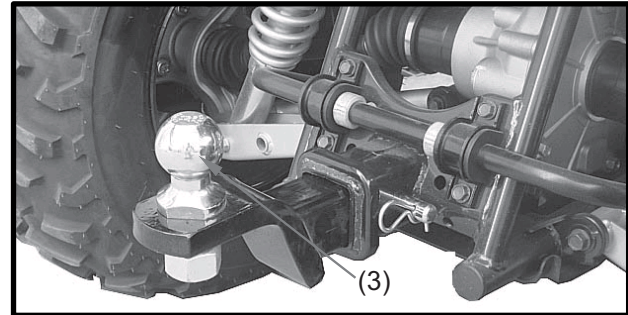

(3) Trailer (LDA0AE/LDA0AD(FR) Version only)

- Load cargo on the cargo racks as close to the center of the vehicle as possible. Put cargo at the rear of the front cargo rack and at the front of the rear cargo rack. Center the load from side to side.
- Tie down cargo securely to the carriers. Make sure cargo in the trailer cannot move around.
- A shifting load can cause an accident.
- Make sure the load does not interfere with controls or your ability to see where you are going.
- Ride more slowly than you would without a load. The more weight you carry, the slower you should go.
- Allow more braking distance. A heavier vehicle takes longer to stop.
- Avoid making sharp turns unless at very slow speeds.
- Avoid hills and rough terrain. Choose terrain carefully. Added weight affects the stability and handling of the ATV.
- Never carry passenger on the cargo racks.

 **WARNING**

POTENTIAL HAZARD

Overloading this ATV or carrying or towing cargo improperly.

WHAT CAN HAPPEN

Could cause changes in vehicle handling which could lead to an accident.

HOW TO AVOID THE HAZARD

Never exceed the stated load capacity for this ATV.

Cargo should be properly distributed and securely attached.

Reduce speed when carrying cargo or pulling a trailer. Allow greater distance for braking.

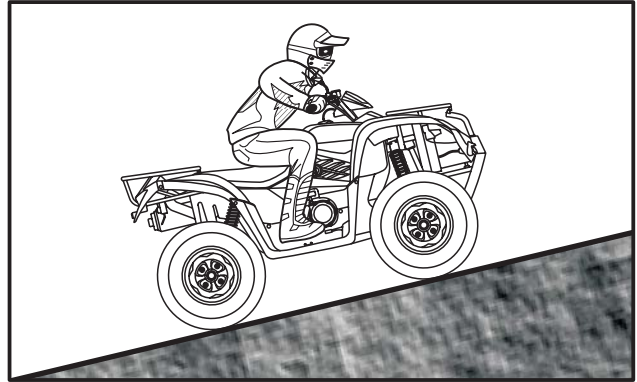
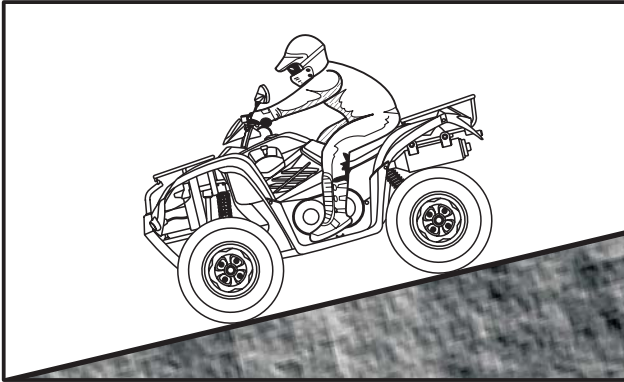

RIDING YOUR ATV

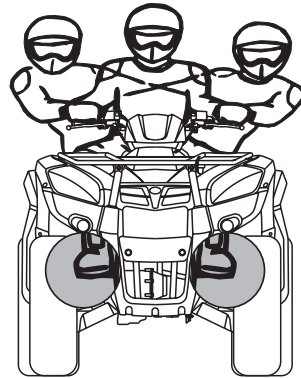



WARNING

Indicates a potential hazard that could result in serious injury or death.

GETTING TO KNOW YOUR ATV

This ATV is for recreation and utility use. This section, riding your ATV, provides general ATV riding instructions for recreational riding. The skills and techniques described in this section, however, are appropriate for all types of riding. Riding your ATV requires special skills acquired through practice over a period of time. Take the time to learn the basic techniques well before attempting more difficult maneuvers.

Riding your new ATV can be a very enjoyable activity, providing you with hours of pleasure. But it is essential to familiarize yourself with the operation of the ATV to achieve the skill necessary to enjoy riding safely.

Before you begin to ride, be sure you have read this Owner's manual completely and understand the operation of the controls. Pay particular attention to the safety information on **pages 4~8**. Please also read all caution and warning labels on your ATV.

RIDE WITH CARE AND GOOD JUDGEMENT

Get training if you are inexperienced.

Beginners and inexperienced riders should get proper instruction on how to operate this ATV.



WARNING

POTENTIAL HAZARD

Operating this ATV without proper instruction.

WHAT CAN HAPPEN

The risk of an accident is greatly increased if the operator does not know how to operate the ATV properly in different situations and on different types of terrain.

HOW TO AVOID THE HAZARD

Become familiar with this ATV at slow speeds first, even if you are an experienced operator.

Do not attempt to operate at maximum performance until you are totally familiar with the machine's handling and performance characteristics.

Riding your machine requires skills acquired through practice over a period of time.

Take the time to learn the basic techniques well before attempting more difficult maneuvers.

Not recommended for children under 16 year of age.



WARNING

POTENTIAL HAZARD

Failure to follow the age recommendations for this ATV.

WHAT CAN HAPPEN

Use by children of ATVs that are not recommended for their age can lead to severe injury or death of the child.

HOW TO AVOID THE HAZARD

A child under 16 should never operate an ATV with engine size greater than 90cc.

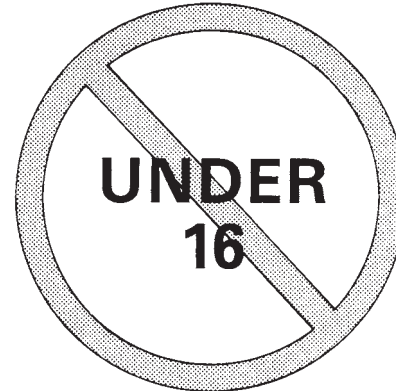

Never carry passenger on the cargo racks.

⚠ WARNING

POTENTIAL HAZARD

Carrying a passenger on the cargo racks.

WHAT CAN HAPPEN

Greatly reduces your ability to balance and control this ATV. Could cause an accident, resulting in harm to you and/or your passenger.

HOW TO AVOID THE HAZARD

Never carry a passenger on the cargo racks. The cargo racks is to allow the operator to carry cargo. It is not for carrying passengers.

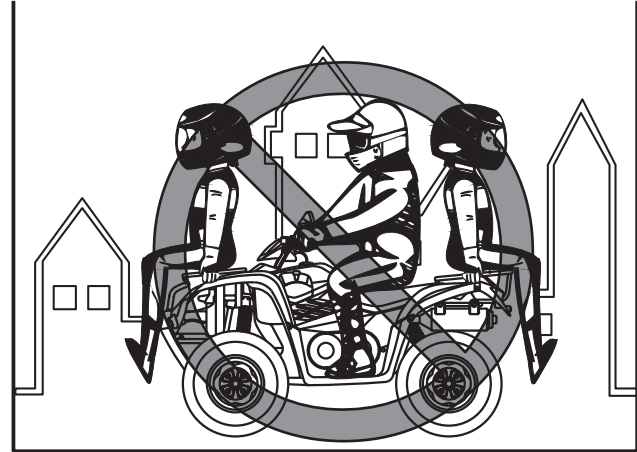

APPAREL



WARNING

POTENTIAL HAZARD

Operating this ATV without wearing an approved motorcycle helmet, eye protection and protective clothing.

WHAT CAN HAPPEN

Operating without an approved motorcycle helmet increases your chances of a severe head injury or death in the event of an accident.

Operating without eye protection can result in an accident and increases your chances of a severe injury in the event of an accident.

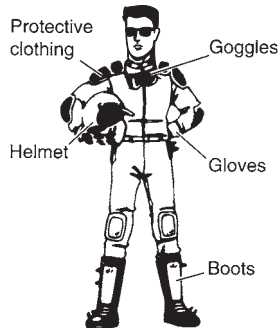

Operating without protective clothing increases your chances of severe injury in the event of an accident.

HOW TO AVOID THE HAZARD

Always wear an approved motorcycle helmet that fits properly.

You should also wear:

- eye protection (goggles or face shield)
- gloves
- boots
- long-sleeved shirt or jacket
- Long pants

Do not operate after consuming alcohol or drugs.

Operator's performance capability is reduced by the influence of alcohol or drugs.



⚠ WARNING

POTENTIAL HAZARD

Operating this ATV after consuming alcohol or drugs.

WHAT CAN HAPPEN

**Could seriously affect your judgment.
Could cause you to react more slowly.
Could affect your balance and perception.
Could result in an accident.**

HOW TO AVOID THE HAZARD

Never consume alcohol or drugs before or while driving this ATV.

PRE-OPERATION CHECKS

Always perform the pre-operation checks listed on **page 47** before riding for safety and proper care of the machine.



WARNING

POTENTIAL HAZARD

Failure to inspect the ATV before operating.
Failure to properly maintain the ATV.

WHAT CAN HAPPEN

Increases the possibility of an accident or equipment damage.

HOW TO AVOID THE HAZARD

Always inspect your ATV each time you use it to make sure the ATV is in safe operating condition.

Always follow the inspection and maintenance procedures and schedules described in the Owner's Manual.



WARNING

POTENTIAL HAZARD

Operating this ATV with improper tires, or with improper or uneven tire pressure.

WHAT CAN HAPPEN

Use of improper tires on this ATV, or operation of this ATV with improper or uneven tire pressure, may cause loss of control, increasing your risk of an accident.

HOW TO AVOID THE HAZARD

Always use the size and type tires specified in the Owner's Manual for this vehicle on pages 58~60.

Always maintain proper tire pressure as described in the Owner's Manual on page 58.

Do not operate at speeds too fast your skills or the conditions.

⚠ WARNING

POTENTIAL HAZARD

Operating this ATV at speeds too fast for your skills or the conditions.

WHAT CAN HAPPEN

Increases your chances of losing control of the ATV, which can result in an accident.

HOW TO AVOID THE HAZARD

Always go at a speed that is proper for the terrain, visibility and operating conditions, and your experience.

Speed limiter

For riders inexperienced with this model, this model is equipped with a speed limiter in the throttle lever housing. The speed limiter limits the power and top speed of the machine.

Turning the screw in decreases top speed, and turning it out increases top speed.

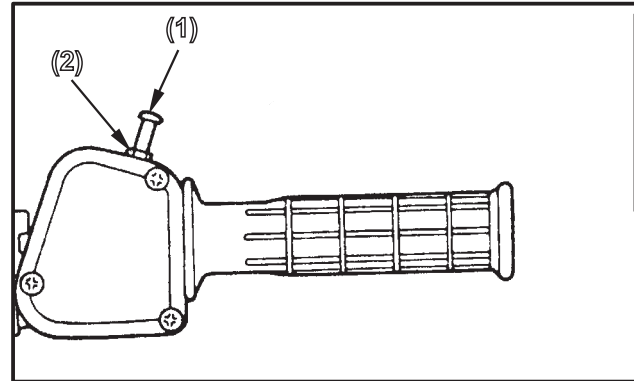

(1) Adjuster (2) Locknut

LOADING AND ACCESSORIES

Use extra caution when riding the machine with additional loads, such as accessories or cargo. The machine's handling may be adversely affected. Reduce your speed when adding additional loads.

MAXIMUM TOWING CAPACITY:

150 kg (330lbs)

TONGUE WEIGHT:

16 kg (35 lbs)

MAXIMUM LOADING LIMIT:

REAR CARGO RACK: 85 kg (187 lbs)

FRONT CARGO RACK: 45 kg (100 lbs)

Loading and operational guidelines

Carrying cargo will affect how your ATV handles and greatly reduce its ability in accelerating, braking and making turns and other maneuvers.

Be sure to observe the weight limits and follow these guidelines:

1. Do not tow another vehicle.
2. Make sure all cargo is secured before riding.
3. Allow extra room for starting, stopping and turning whenever you carry cargo or pull a trailer.
4. Avoid riding on steep slopes when carrying cargo or pulling a trailer.
5. Never cross a slope when towing a trailer.



WARNING

POTENTIAL HAZARD

Overloading this ATV or carrying or towing cargo improperly.

WHAT CAN HAPPEN

Could cause changes in vehicle handling, stability and braking which could lead to an accident.

HOW TO AVOID THE HAZARD

Never exceed the stated load capacity for this ATV.

Cargo should be properly distributed and securely attached.

Reduce speed when carrying cargo or pulling a trailer. Allow greater distance for braking.

Always follow the instructions in your Owner's Manual for carrying cargo or pulling a trailer.

Accessories

Genuine KYMCO accessories have been specifically designed for and tested on this vehicle. Because KYMCO cannot test all other accessories, you are personally responsible for properly selecting, installing, and using non-KYMCO accessories. Always follow the loading instructions above, plus the following:

1. Carefully inspect the accessory to make sure it does not block any lights, reduce ground clearance, or limit suspension travel, steering travel, or other controls.
2. Make sure the accessory does not interfere with your ability to shift body position on the seat or operate hand and foot controls.
3. Do not add electrical equipment that will exceed the vehicle's electrical system capacity. A blown fuse could cause a loss of lights or engine power.

MODIFICATIONS



WARNING

POTENTIAL HAZARD

Operating this ATV with improper modifications.

WHAT CAN HAPPEN

Improper installation of accessories or modification of this vehicle may cause changes in handling which in some situations could lead to an accident.

HOW TO AVOID THE HAZARD

Never modify this ATV through improper installation or use of accessories. All parts and accessories added to this vehicle should be genuine KYMCO or equivalent components designed for use on this ATV and should be installed and used according to instruction. If you have question, consult an authorized ATV dealer.

No modifications

Modifying this ATV or removing original equipment may render the vehicle unsafe or illegal. Spark arresters and mufflers are required in most areas. Don't modify your exhaust system or emission control system components. Remember, excessive noise bothers everyone and creates a bad image for ATV.

DURING OPERATION

Always keep your feet on the footboards during operation. Otherwise your feet may contact the rear wheels.

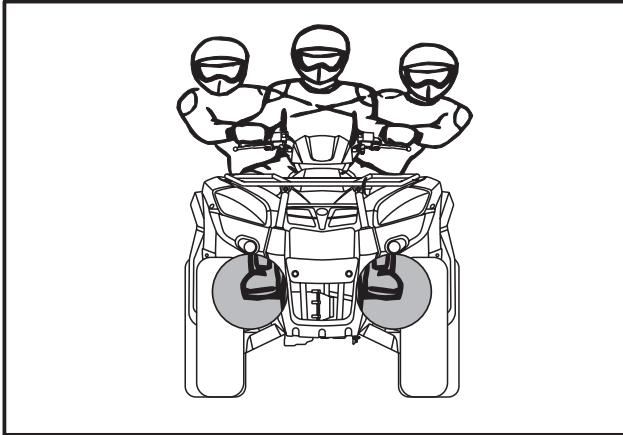

⚠ WARNING

POTENTIAL HAZARD

Removing hands from handlebars or feet from footboards during operation.

WHAT CAN HAPPEN

Removing even one hand or foot can reduce your ability to control the ATV or could cause you to lose your balance and fall a footpeg, your foot or leg may come into contact with the rear wheels, which could injure you or cause an accident.

HOW TO AVOID THE HAZARD

Always keep both hands on the handlebars and both feet on the footpegs of your ATV during operation.

Avoid wheelies and jumping. You may lose control of the machine or overturn.



WARNING

POTENTIAL HAZARD

Attempting wheelies, jumps, and other stunts.

WHAT CAN HAPPEN

Increases the chance of an accident, including an overturn.

HOW TO AVOID THE HAZARD

Never attempt stunts, such as wheelies or jumps. Don't try to show off.

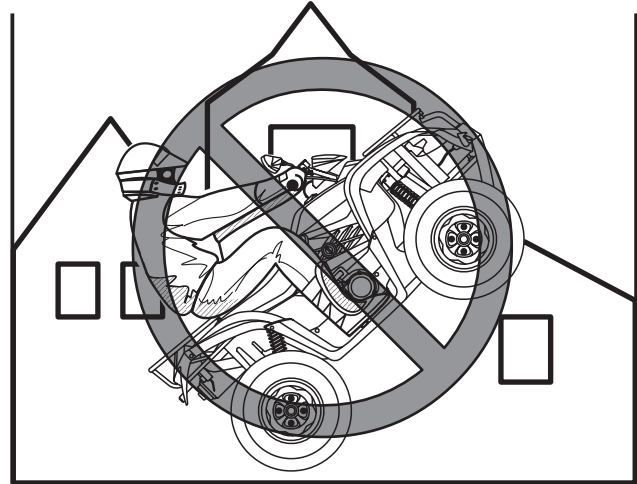

EXHAUST SYSTEM

The exhaust on the machine is very hot during and following operation. To prevent burns, avoid touching the exhaust system. Park the machine in a place where pedestrians or children are not likely to touch it.

⚠ WARNING

POTENTIAL HAZARD

Hot exhaust system

WHAT CAN HAPPEN

Someone touching the exhaust system during or after operation could be burned.

HOW TO AVOID THE HAZARD

Do not touch the hot exhaust system.

Do not park the machine in a place where others might be likely to touch it.

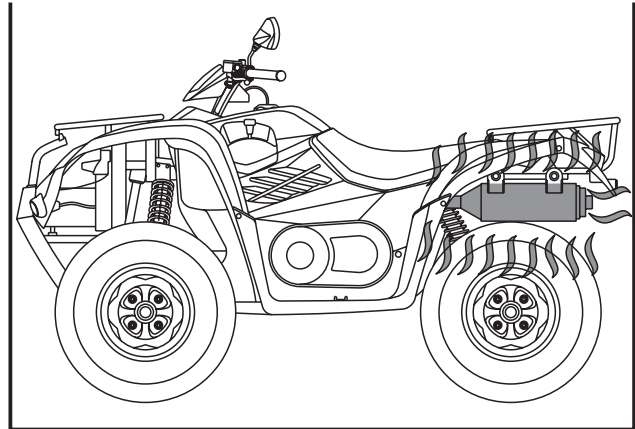

PRACTICING

Select a flat area to become familiar with your ATV. Make sure that this area is free of obstacles and other riders. You should practice control of the throttle, brakes, shifting before trying more difficult terrain.

Always avoid riding on rough surfaces: the ATV is designed for on-road use only, and handling maneuvers are more difficult to perform on rough surfaces.

Set the parking brake and follow the instruction on **page 62~66** to start the engine. Once it has warmed up you are ready to begin riding your ATV. Remember that the engine and exhaust pipe will be hot when riding and afterwards; do not allow skin or clothing to come in contact with these components.

With the engine idling, return the starter knob to the closed position and shift the drive select lever into the forward position. Then release the parking brake. Apply the throttle slowly and you will start to accelerate. If the throttle is applied too abruptly, the front wheels may lift off the ground resulting in a loss of directional control. Avoid higher speeds until you are thoroughly familiar with the operation of your ATV.

When slowing down or stopping, release the throttle and apply the brakes smoothly and evenly. Improper use of the brakes can cause the tires to lose traction, reducing control and increasing the possibility of an accident.

TURNING YOUR ATV

To achieve maximum traction while riding on-road, the two rear wheels are mounted solidly on one axle and turn together at the same speed. Therefore, unless the wheel on the inside of the turn is allowed to slip or lose some traction, the ATV will resist turning.

When approaching a corner or turn, close the throttle fully, and slow the ATV down by applying both front and rear brakes at the same time.

As you do so, put your weight on the footboard to the outside of the turn (opposite your desired direction) and lean your upper body into the turn. After completing the turn, open the throttle gradually to accelerate the ATV.

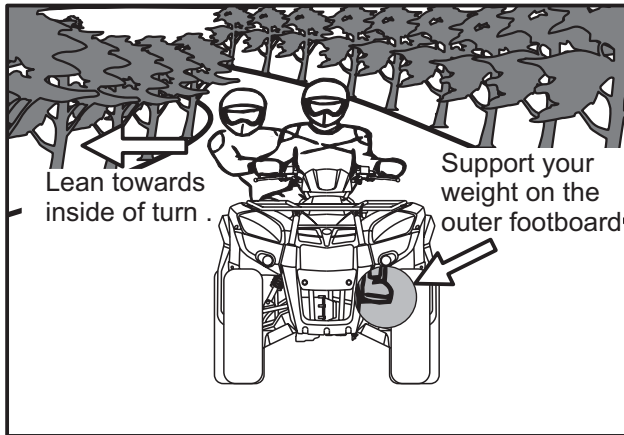

WARNING

POTENTIAL HAZARD

Turning improperly

WHAT CAN HAPPEN

ATV could go out of control, causing a collision or overturn.

HOW TO AVOID THE HAZARD

Always follow proper procedures for turning as described in this Owner's Manual.

Practice turning at low speeds before attempting to turn at faster speeds. Do not turn at speeds too fast for your skills or the conditions.

Do not turn at excessive speeds.

CLIMBING UP SLOPE

Use proper riding techniques to avoid vehicle overturns on slopes. Be sure that you can maneuver your ATV well on flat ground before attempting any incline and then practice riding first on gentle slopes. Try more difficult climbs only after you have developed your skill. In all cases avoid inclines with slippery or loose surfaces, or obstacles that might cause you to lose control.

WARNING

POTENTIAL HAZARD

Operating on excessively steep slopes.

WHAT CAN HAPPEN

The vehicle can overturn more easily on extremely steep slopes than on level surfaces or small slopes.

HOW TO AVOID THE HAZARD

**Never operate the ATV on slopes too steep for the ATV or for your abilities.
Practice on smaller slopes before attempting large slopes.**

It is important when climbing a slope to make sure that your weight is transferred forward on the ATV. This can be accomplished by leaning forward, steeper inclines and standing on the footboards and leaning forward over the handlebars.



WARNING

POTENTIAL HAZARD

Climbing slopes improperly

WHAT CAN HAPPEN

Could cause loss of control or cause the ATV to overturn.

HOW TO AVOID THE HAZARD

Always follow proper procedures for climbing slopes as described in this Owner's Manual.

Always check the terrain carefully before you start up any slope.

Never climb slopes with excessively slippery or loose surfaces.

Shift your weight forward.

Never open the throttle suddenly.

The ATV could flip over backwards.

Never go over the top of any slope at high speed.

An obstacle or a sharp drop could be on the other side of the slope.

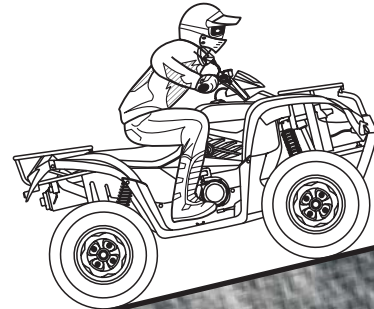

If you are climbing a slope and you find that you have not properly judged your ability to make it to the top, you should turn the ATV around while you still have forward motion (provided you have the room to do so) and go down the slope.



WARNING

POTENTIAL HAZARD

Improperly crossing slopes or turning on slopes.

WHAT CAN HAPPEN

Could cause loss of control or cause the ATV to overturn.

HOW TO AVOID THE HAZARD

Never attempt to turn the ATV around on any slope until you have mastered the turning technique as described in the Owner's Manual on level ground. Be very careful when turning on any slope. Avoid crossing the side of a steep slope if possible.

When crossing the side of a slope:

Always follow proper procedures as described in the Owner's Manual.

Avoid slopes with excessively slippery or loose surfaces.

Shift your weight to the up of slope side of the ATV.

OK



If your ATV has stalled or stopped and you believe you can continue up the slope, restart carefully to make sure you do not lift the front wheels which could cause you to lose control. If you are unable to continue up the slope, dismount the ATV on up slope side. Physically turn the ATV around and then descend the slope.

If you start to roll backwards, DO NOT apply either brake abruptly. If you are in 2WD, apply only the front brake. When this ATV is in 4WD, all wheels (front and rear) are interconnected by the drive train. This means that applying either the front brake or the rear brake will brake all wheels. When descending slope, using either brake lever or the brake pedal will brake the wheels on the downslope side. Avoid sudden application of either the front or rear brake because the wheels on the upslope side could come off the ground. The ATV could easily tip over backwards. Apply both the front and rear brakes gradually, or dismount the ATV immediately on the up of slope side..

WARNING

POTENTIAL HAZARD

Stalling, rolling backwards or improperly dismounting while climbing a slope.

WHAT CAN HAPPEN

Could result in ATV overturning.

HOW TO AVOID THE HAZARD

Maintain steady speed when climbing a slope.

If you lose all forward speed:

Keep weight up slope.

Apply the brakes.

Shift to the parking position “P” after you are stopped.

Lock parking brake.

If you begin rolling backwards:

Keep weight up slope.

2WD: Never apply the rear brake while rolling backwards.

Apply the front brake.

4WD: Apply both front and rear brakes gradually.

When fully stopped, shift to the parking position "P".

When fully stopped, apply front brake as well, and then lock parking brake.

Dismount on up slope side or to a side if pointed straight up slope. Turn the ATV around and remount, following the procedure described in the Owner's Manual.

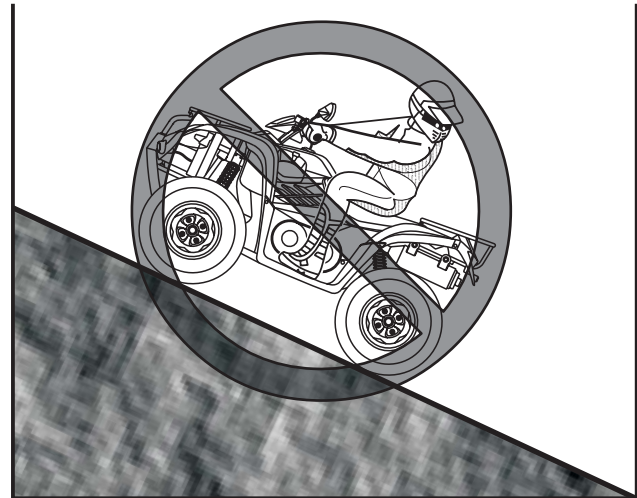

If the slope is not too steep and you have good footing, you may be able to walk the ATV back down the slope. Make sure your intended path is clear in case you lose control of the ATV. If you decide you can walk the ATV safely:

1. Stand with your body facing downslope, beside the vehicle so you can reach the front brake lever with your left hand.
2. Be sure your legs are clear of the wheels.
3. Check your footing.
4. Then slowly and carefully back the ATV down the slope using the front brake lever to control speed.
5. If you lose control of the ATV, for your safety, get away from the vehicle.

If the slope is too steep or too slippery, or if you have any doubt whether you can safely walk the ATV back down the slope, leave the vehicle where it is and get help. If possible, block the wheels so the vehicle won't roll backwards.

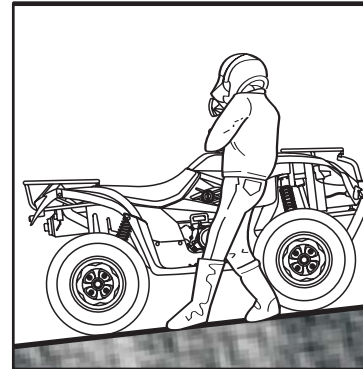
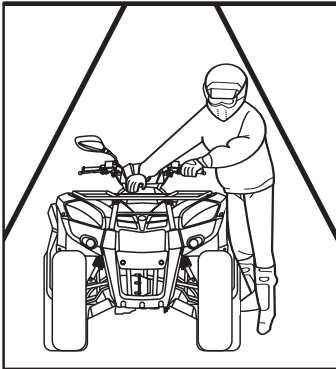

RIDING DOWN SLOPE

When riding your ATV down slope, shift your weight as far to the rear and up slope side of the ATV as possible. Move back on the seat and sit with your arms straight. Engine compression will do most of the braking for you. For maximum engine compression braking effect, select low range “L” and change to 4WD before beginning to descend the slope. Improper braking may cause a loss of traction.

Use caution while descending a slope with loose or slippery surfaces. Braking ability and traction may be adversely affected by these surfaces. Improper braking may also cause a loss of traction.

When this ATV is in 4WD, all wheels (front and rear) are interconnected by the drive train. This means that applying either the front brake or the rear brake will brake all wheels. When descending slope, using either brake lever or the brake pedal will brake the wheels on the downslope side. Avoid sudden application of either the front or rear brake because the wheels on the up of slope side could come off the ground. Apply both the front and rear brakes gradually.

Whenever possible, ride your ATV straight down slope. Avoid sharp angles which could allow the ATV to tip or roll over. Carefully choose your path and ride no faster than you will be able to react to obstacles which may appear.

WARNING

POTENTIAL HAZARD

Going down a slope improperly.

WHAT CAN HAPPEN

Could cause loss of control or cause the ATV to overturn.

HOW TO AVOID THE HAZARD

Always follow proper procedures for going down slopes as described in this Owner's Manual. Note: a special technique is required when braking as you go down a slope.

Always check the terrain carefully before you start down any slope.

Shift your weight backward.

Never go down a slope at high speed.

Avoid going down a slope at an angle that would cause the vehicle to lean sharply to one side. Go straight down the slope where possible.

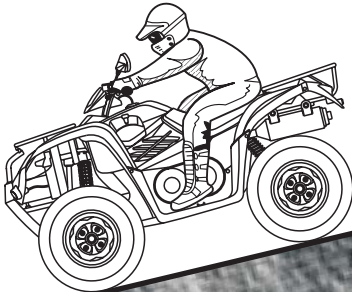

PARKING

Always choose a level place to park. After bringing your ATV to a stop, hold the brakes while you shift into park position. Then set the parking brake and turn the ignition switch OFF. If you're through riding for the day, also turn the fuel valve OFF.

WHAT TO DO IF

This section is designed to be a reference guide only. Be sure to read each section on riding techniques completely.

WHAT TO DO....

If your ATV doesn't turn when you want it to: Bring the ATV to a stop and practice the turning maneuvers again. Be sure you are putting your weight on the footboard to the outside of the turn. Position your weight over the front wheels for better control. **(See pages 91.)**

If your ATV can't make it up a slope you are trying to climb:

Turn the ATV around if you still have forward speed. If not, stop, dismount on the up slope side of the ATV and physically turn the ATV around. If the ATV starts to slip backwards **DO NOT USE THE REAR BRAKE** - the ATV may tip over on top of you. Dismount the ATV on the up slope side. **(See pages 91~97.)**

PERIODIC MAINTENANCE AND ADJUSTMENT

Periodic inspection, adjustment and lubrication will keep your machine in the safest and most efficient condition possible. Safety is an obligation of the machine owner. The most important points of machine inspection, adjustment and lubrication are explained on the following pages.

WARNING

POTENTIAL HAZARD

Servicing an engine while it is running.

WHAT CAN HAPPEN

Moving parts can catch clothing or parts of the body, causing injury.

Electrical components can cause shocks or can start fires.

HOW TO AVOID THE HAZARD

Turn off the engine when performing maintenance unless otherwise specified.

Have KYMCO dealer perform service if you are not familiar with machine service.

TOOL KIT/TOOL KIT COMPARTMENT

The tool kit is stored in the tool kit compartment under the seat.

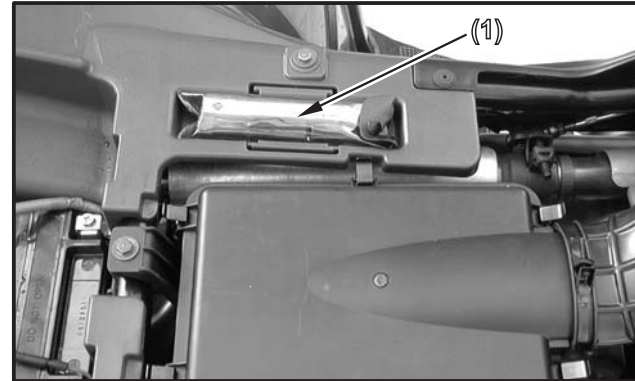

(1) Tool kit/Tool kit compartment

The tools in the kit are sufficient to perform routine maintenance and simple repairs. Any extensive work requiring additional tools should be performed by your authorized KYMCO dealer.

The tool kit includes the following items:

- (1) Air pressure gauge
- (2) Spark plug wrench(A)
- (3) 10/14 mm wrench
- (4) Standard/Phillips screwdriver
- (5) Screwdriver handle
- (6) Tool bag
- (7) Spark plug wrench(B)
- (8) Rear cushion adjuster ,



WARNING

POTENTIAL HAZARD

Operating this ATV with improper modifications.

WHAT CAN HAPPEN

Improper installation of accessories or modification of this vehicle may cause changes in handling which in some situation could lead to an accident.

HOW TO AVOID THE HAZARD

Never modify this ATV through improper installation or use of accessories. All parts and accessories added to this vehicle should be genuine KYMCO or equivalent components designed for use on this ATV and should be installed and used according to instructions. If you have questions, consult an authorized KYMCO dealer.

PERIODIC MAINTENANCE/LUBRICATION

ITEM	WHICHEVER COMES FIRST	ROUTINE			
			INITIAL	EVERY	
		mi	100	600	1200
		Km	150	1000	2000
		MONTH	1	6	12
Engine oil	•Replace (Warm engine before draining).		<input type="radio"/>	<input type="radio"/>	<input type="radio"/>
*Oil strainer	•Clean. •Replace if necessary.		<input type="radio"/>	<input type="radio"/>	<input type="radio"/>
Engine oil filter cartridge	•Replace		<input type="radio"/>	<input type="radio"/>	<input type="radio"/>
Final gear oil	•Check oil level/oil leakage •Replace every 12 months.		<input type="radio"/>		<input type="radio"/>
Differential gear oil	•Check oil level/oil leakage •Replace every 12 months.		<input type="radio"/>		<input type="radio"/>
Air filter element (for engine and *V-belt compartment)	•Clean. (More often in wet or dusty areas.) •Replace if necessary.			<input type="radio"/>	<input type="radio"/>
*Throttle body	•Check idle speed/starter operation. •Adjust if necessary.				<input type="radio"/>
*Cylinder head cover breather system	•Check breather hose for cracks or damage. •Replace if necessary.			<input type="radio"/>	<input type="radio"/>
Spark plug	•Check condition. •Adjust gap and clean. •Replace if necessary.		<input type="radio"/>	<input type="radio"/>	<input type="radio"/>
*Fuel line	•Check fuel hose for cracks or damage. •Replace if necessary.			<input type="radio"/>	<input type="radio"/>
*Valves	•Check valve clearance. •Adjust if necessary.		<input type="radio"/>	<input type="radio"/>	<input type="radio"/>

(Cont'd)

ITEM	WHICHEVER COMES FIRST ROUTINE	INITIAL		EVERY	
		mi	100	600	1200
		Km	150	1000	2000
		MONTH	1	6	12
*Brake	<ul style="list-style-type: none"> •Check operation and brake fluid. •Replace brake pad if necessary. 		<input type="radio"/>	<input type="radio"/>	<input type="radio"/>
*Coolant	<ul style="list-style-type: none"> •Check coolant leakage. •Replace if necessary. •Replace coolant every 24 months. 		<input type="radio"/>	<input type="radio"/>	<input type="radio"/>
*V-belt	<ul style="list-style-type: none"> •Check operation. •Replace if damage or excessive wear. 		<input type="radio"/>		<input type="radio"/>
*Exhaust system	<ul style="list-style-type: none"> •Check leakage. •Retighten if necessary. •Replace gasket if necessary. 			<input type="radio"/>	<input type="radio"/>
Spark arrester	<ul style="list-style-type: none"> •Clean 			<input type="radio"/>	<input type="radio"/>
*Wheels	<ul style="list-style-type: none"> •Check balance/damage/runout. •Replace if necessary. 		<input type="radio"/>	<input type="radio"/>	<input type="radio"/>
*Wheel bearings	<ul style="list-style-type: none"> •Check bearing assembly for looseness/damage. •Replace if damaged. 		<input type="radio"/>	<input type="radio"/>	<input type="radio"/>
*Steering system	<ul style="list-style-type: none"> •Check operation. •Replace if damaged. •Check toe-in. •Adjust if necessary. 		<input type="radio"/>	<input type="radio"/>	<input type="radio"/>
*Drive shaft boots	<ul style="list-style-type: none"> •Check operation. •Replace if damaged. 			<input type="radio"/>	<input type="radio"/>
*Suspension	<ul style="list-style-type: none"> •Check operation. •Correct if necessary. 			<input type="radio"/>	<input type="radio"/>

(Cont'd)

ITEM	WHICHEVER COMES FIRST ROUTINE	INITIAL		EVERY	
		mi	100	600	1200
		Km	150	1000	2000
		MONTH	1	6	12
*Knuckle shafts/ Steering shaft	•Lubricate every 6 months.			<input type="radio"/>	<input type="radio"/>
*Fittings and Fasteners	•Check all chassis fittings and fasteners. •Correct if necessary.		<input type="radio"/>	<input type="radio"/>	<input type="radio"/>

* : It is recommended that these items be serviced by a KYMCO dealer.

** : Lithium soap base grease.

ENGINE OIL

1. Engine oil level measurement

- A. Place the machine on a level place.
- B. Warm up the engine for several minutes and stop it.
- C. Check the oil level through the inspection window.
- D. The oil level should be between the maximum (H) and minimum (L) marks. If the level is low, add oil to raise it to the proper level.

NOTE:

Wait a few minutes until the oil level settles before checking.

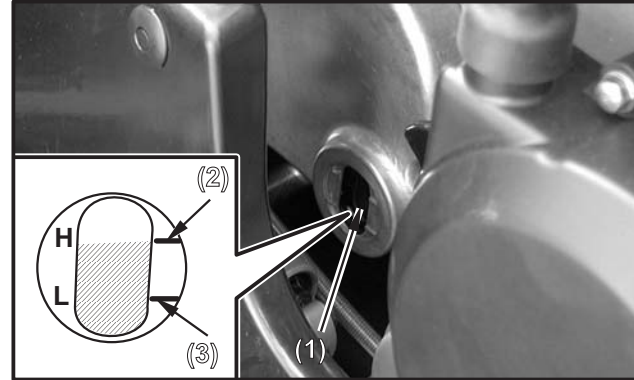

(1) Engine oil inspection window

(2) Maximum level mark (H)

(3) Minimum level mark (L)

2-1. Engine oil replacement and oil filter cleaning

- A. Place the machine on a level place.
- B. Warm up the engine for several minutes and stop it.
- C. Place a container under the engine.
- D. Remove the oil fill cap (1) and oil filter cap (2) to drain the oil.

CAUTION:

Be sure no foreign material enters the crankcase.

CAUTION:

When removing the oil filter cap, the compression spring, oil strainer and O-ring will fall out. Take care not to lose these parts.

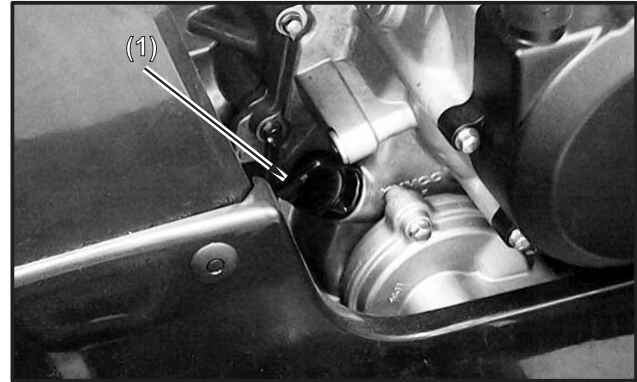

(1) Oil fill cap

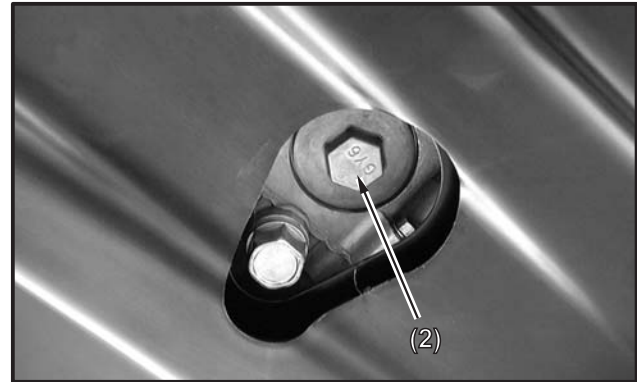

(2) Oil filter cap

- E. Clean the oil strainer with solvent.
- F. Inspect the O-ring and replace if damaged.
- G. Reinstall the O-ring, oil strainer, compression spring and oil filter cap. Tighten the oil filter cap to specification.

CAUTION:

Before reinstalling the drain plug, be sure to install the O-ring, compression spring and oil strainer.

Tightening torque:

Oil filter cap (engine):
14.7 N-m (1.5 kgf-m, 11 lbf-ft)

- H. Fill the engine with oil and install the oil fill cap.

Recommended oil: see **page 146**

Oil quantity:

Periodic oil change:

3 L (2.64 Imp qt, 3.18 US qt)

After draining and oil filter cartridge change:

3.2 L (2.82 Imp qt, 3.39 US qt)

Total amount:

3.6 L (3.17 Imp qt, 3.82 US qt)

CAUTION:

Be sure no foreign material enters the crankcase.

- I. Warm up the engine for several minutes at idle speed. Check for oil leakage while warming up.

CAUTION:

If oil leakage is found, stop the engine immediately and check for the cause.

2-2. Engine oil replacement (with or without oil filter cartridge replacement)

- A. Place the machine on a level place.
- B. Warm up the engine for several minutes and stop it.
- C. Place a container under the engine.
- D. Remove the oil fill cap (1) and drain plug/washer (2) to drain the oil.

CAUTION:

Be sure no foreign material enters the crankcase.

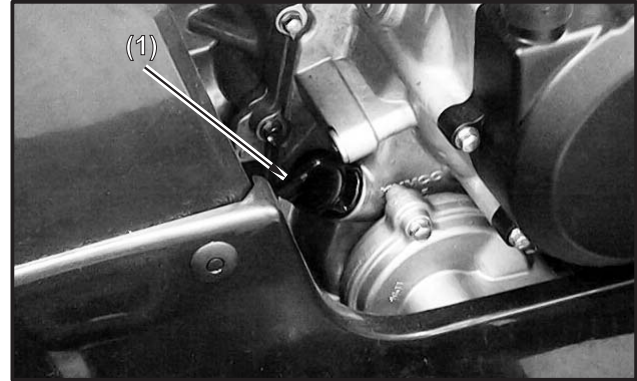

(1) Oil fill cap



(2) Drain plug/washer

NOTE:

Skip steps E to I if the oil filter cartridge is not being replaced.

E. Remove the three fasteners (3) and then remove right side cover (4).

F. Remove the oil filter cartridge (5) with an oil cartridge wrench.

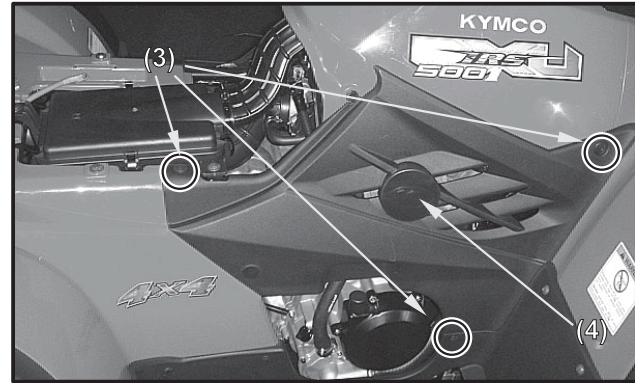

(3) Fasteners (4) Right side cover

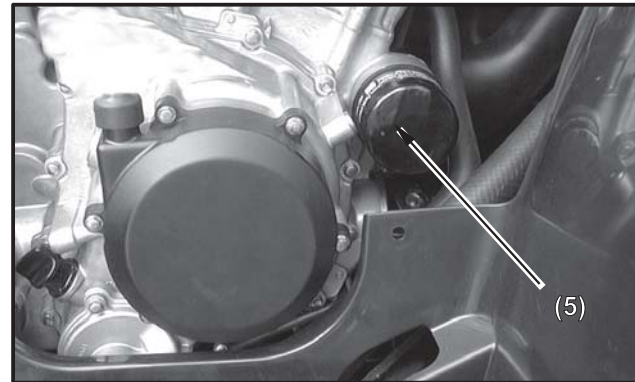

(5) Oil filter cartridge

G. Apply a light coat of clean engine oil to the O-ring (6) of the new oil filter cartridge.

NOTE:

An oil cartridge wrench is available at a nearby KYMCO dealer

NOTE:

Make sure the O-ring is seated properly.

H. Install the new oil filter cartridge with an oil cartridge wrench, and then tighten it to the specified torque.

Tightening torque:
Oil filter cartridge:
10 N-m (1 kgf-m, 7.2 lbf-ft)

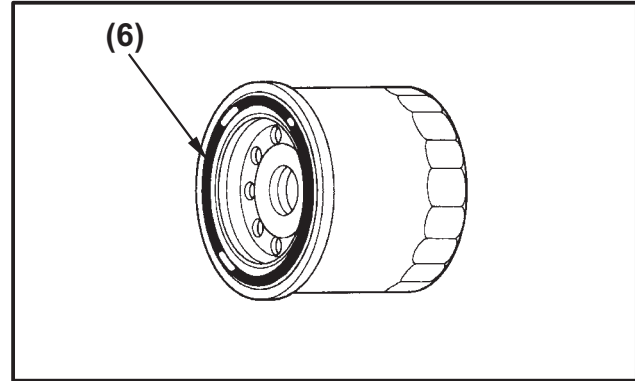

(5) O-ring

- I. Install right side cover.
- J. Reinstall the drain plug/washer and tighten the drain plug to the specified torque.

Tightening torque:
Drain plug (engine):
25 N-m (2.5 kgf-m, 18 lbf-ft)

- K. Add the specified amount of recommended engine oil, and then install the engine oil filler cap and tighten it.

Recommended oil: see **page 146**.

Oil quantity: see **page 146**.

CAUTION:

Be sure no foreign material enters the crankcase.

- L. Start the engine and warm it up for several minutes. While warming up, check for oil leakage. If oil leakage is found, turn the engine off immediately and check for the cause.
- M. Turn the engine off, and then check the oil level through the inspection window (7) and correct it if necessary.

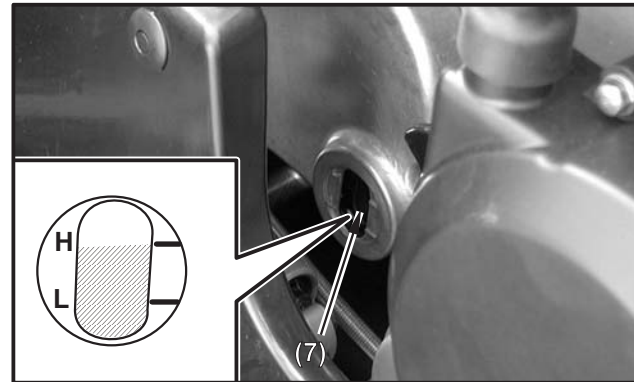

(7) Engine oil inspection window

Rear Gear Box Oil

Change the oil in the rear gear box case when specified by the Maintenance Schedule. Change the oil with the rear gear box warm, and the ATV on level ground to assure complete and rapid draining.

Rear gear box oil replacement

To drain the oil, first place an oil drain pan under the oil drain plug (1).

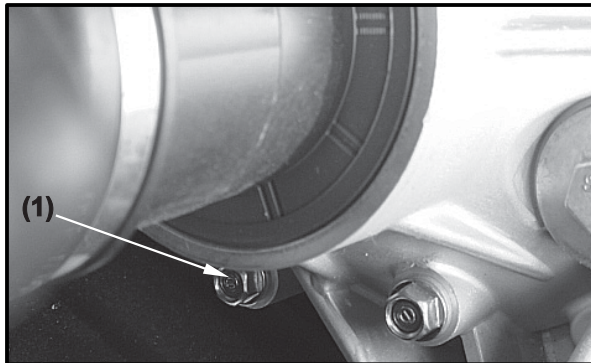

(1) Oil drain plug

3. Remove the oil filler cap (2), then remove the drain plug/washer.
4. After the oil has completely drained, reinstall the drain plug/washer.

Tightening torque
Drain plug: 20 N-m (2 kgf-m, 15 lbf-ft)

5. Fill the gear case with the recommended oil.

Recommended oil : SAE 80
Oil quantity :
Periodic oil change
0.23 L (0.20 Imp qt, 0.243 US qt)

Remove the oil level check bolt/washer (2).
Make sure the oil level reaches the oil level check hole.

6. Install the oil filler cap and oil level check bolt.

Tightening torque:
Oil filler cap: 14.7 N-m (1.5 kgf-m, 11 lbf-ft)
Oil level check bolt:
20 N-m (2 kgf-m, 15 lbf-ft)

7. Install the skid plate.

CAUTION:

Be sure no foreign material enters the gear case.

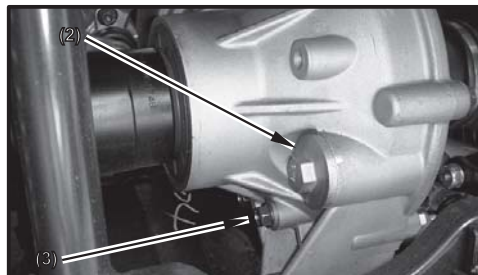

- (2) Oil filler cap
- (3) Oil level check bolt/washer

FRONT GEAR BOX OIL

Change the oil in the front gear box when specified by the Maintenance Schedule. Change the oil with the front gear box warm, and the ATV on level ground to assure complete and rapid draining.

Front gear box oil replacement

1. To drain the oil, first place an oil drain pan under the oil drain plug/washer (1).
2. Remove the oil filler bolt/washer (2).

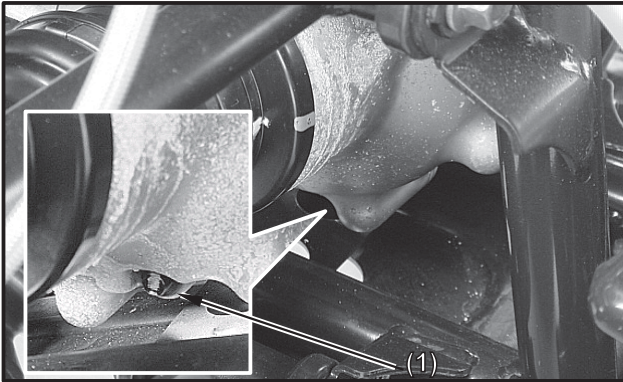

(1) Oil drain plug/washer

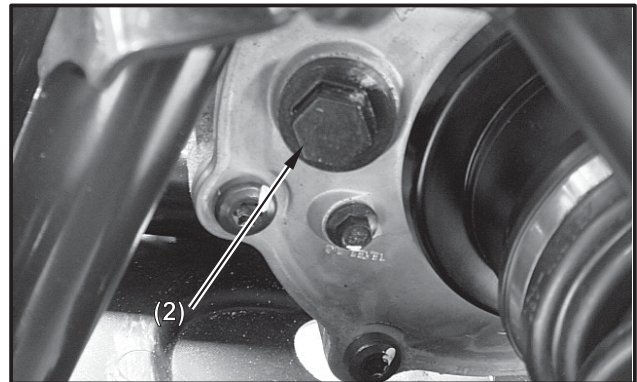

(2) Oil filler bolt/washer

3. Remove the drain plug.
4. After the oil has completely drained, reinstall the drain plug/washer.

Tightening torque

Drain plug: 32 N-m (3.2 kgf-m, 23 lbf-ft)

5. Fill the gear case with the recommended oil.

Recommended oil : SAE 80

Oil quantity :

Periodic oil change

0.25 L (0.22 Imp qt, 0.265 US qt)

Remove the oil level check bolt/washer
(3).

Make sure the oil level reaches the oil
level check hole.

6. Install the oil filler bolt/washer and oil
level check bolt/washer.

Tightening torque:

Oil filler bolt: 35 N-m (3.5 kgf-m, 25.5 lbf-ft)

Oil level check bolt:

10 N-m (1 kgf-m, 7.2 lbf-ft)

CAUTION:

Be sure no foreign material enters the gear case.

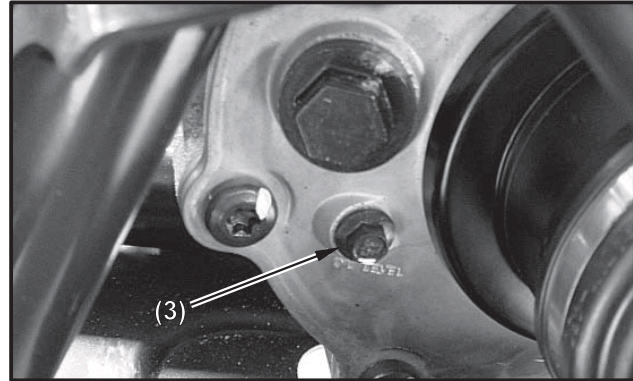

(3) Oil level check bolt

SPARK PLUG INSPECTION

The spark plug is an important engine component and is easy to inspect. The condition of the spark plug can indicate the condition of the engine.

For example, a very white center electrode porcelain color could indicate an intake air leak or carburetion problem for that cylinder. Do not attempt to diagnose such problems yourself. Instead, take the machine to a KYMCO dealer. You should periodically remove and inspect the spark plug because heat and deposits will cause the spark plug to slowly break down and erode. If electrode erosion becomes excessive, you should replace the spark plug with one of the proper type.

Standard spark plug (NGK): CR7E

Before installing the spark plug, measure the electrode gap with a feeler gauge and adjust to specification.

Spark plug gap:
0.6~0.7 mm (0.024~0.028 in)

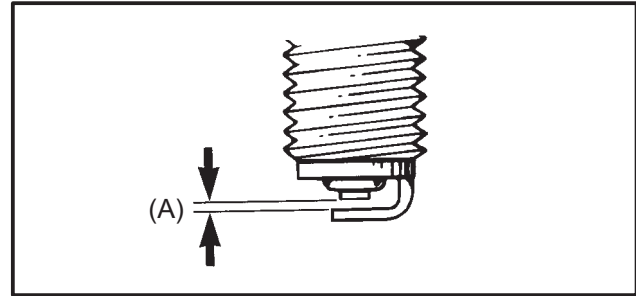

(A) Spark plug gap

When installing the spark plug, always clean the gasket surface and use a new gasket. Wipe off any grime from the threads and tighten to the specified torque.

Tightening torque:
Spark plug:
17.2 N-m (1.72 kgf-m, 13 lbf-ft)

SPARK ARRESTER

Be sure the exhaust pipe and muffler are cool before cleaning the spark arrester.

1. Remove the three bolts (1), the spark arrester (2) and the gasket (3) from the muffler.

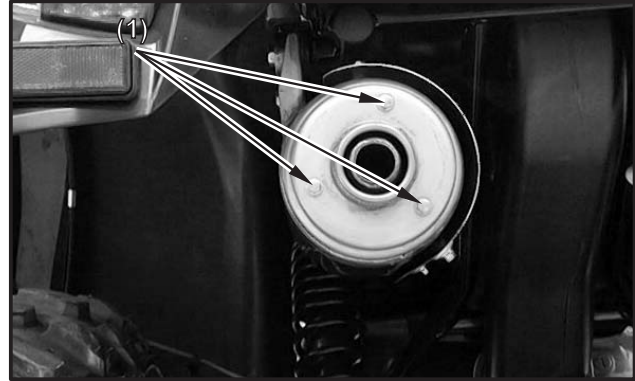

(1) Bolts

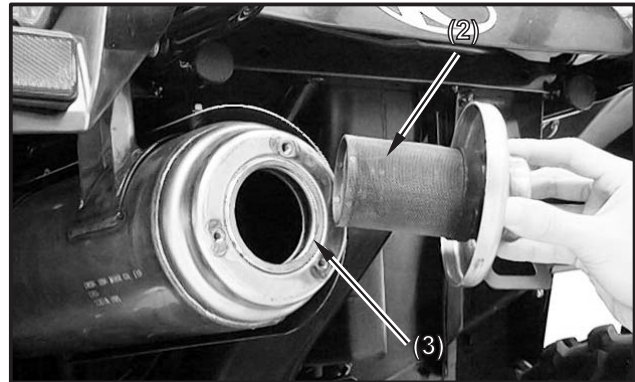

(2) Spark arrester (3) Gasket

2. Use a brush to remove carbon deposits from the spark arrester screen. Be careful to avoid damaging the spark arrester screen. The spark arrester must be free of breaks and holes. Replace, if necessary. Check the gasket. Replace, if necessary.
3. Install the spark arrester and the gasket in the muffler and tighten the three bolts securely.

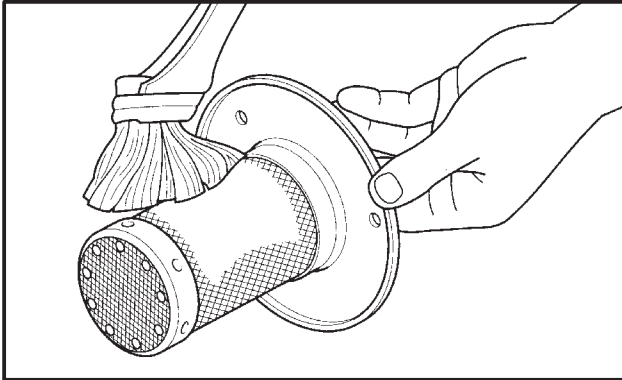

⚠ WARNING

POTENTIAL HAZARD

**Improper cleaning of the spark arrester.
Hot exhaust system.**

WHAT CAN HAPPEN

Could injure the eyes.

Could cause burns.

**Could cause carbon monoxide poisoning,
possibly leading to death.**

Could start a fire

HOW TO AVOID THE HAZARD

When cleaning the spark arrester:

**Always let the exhaust system cool prior to
touching exhaust components**

**Do not start the engine when cleaning the
exhaust system.**

AIR FILTER CLEANING

The air cleaner accumulates dust and must be cleaned periodically. If the ATV is ridden in dusty areas, the air cleaner must be cleaned at more frequent intervals than specified in the Maintenance Schedule. If the ATV is submerged in water, the air cleaner should be checked and water should be drained from the air cleaner housing before starting the engine.

To clean the air cleaner:

1. Remove the seat. **(See page 43.)**
2. Unlatch the six retainer clips (1) and remove the air cleaner housing cover (2).
3. Loosen the screw (3) and remove the air cleaner assembly (4) from the air cleaner housing.
4. Unscrew the clamp (5)

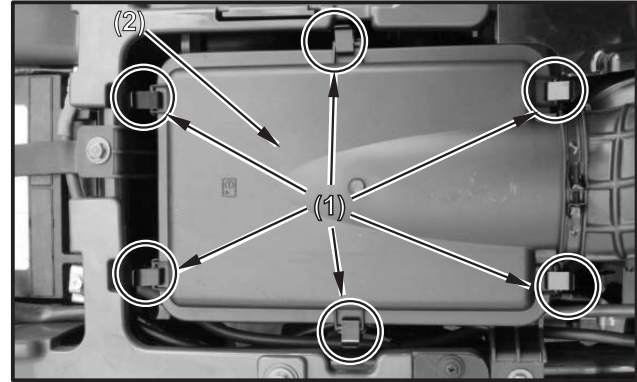

(1) Retainer clips (2) Air cleaner housing cover



(3) Screw (4) Air cleaner assembly (5) Clamp

5. Remove the outer air cleaner (7).
6. Remove the screw/washers (6) and remove the air cleaner assembly from the air cleaner holder (8).
7. Remove the inner air cleaner (9) and air cleaner screen (10) from the air cleaner guide (11).
8. Remove the air cleaner screen from the inner air cleaner.

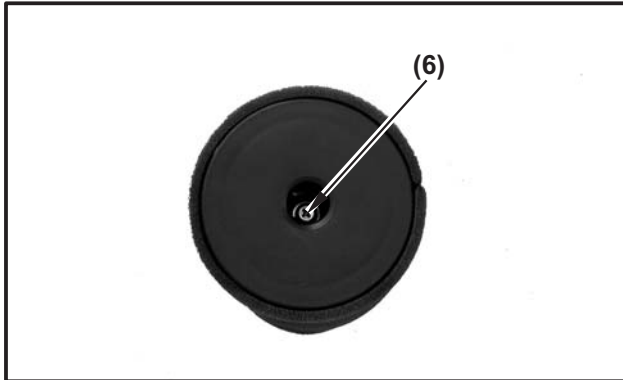

(6) Screw/washer

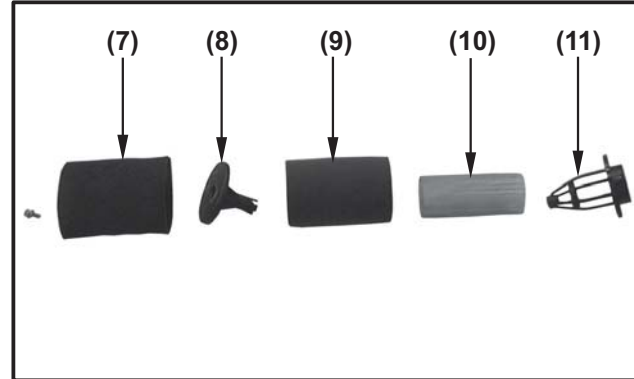

- (7) Outer air cleaner
- (8) Air cleaner holder
- (9) inner air cleaner
- (10) Air cleaner screen
- (11) Air cleaner guide

9. Gently wash the air cleaner in clean, non-flammable (high flash point) solvent such as kerosene —not gasoline. Allow the air cleaner to dry thoroughly before applying oil. A wet air cleaner will not fully absorb the oil.

 **WARNING**

POTENTIAL HAZARD

Using gasoline or low flash point solvents for cleaning ATV parts.

WHAT CAN HAPPEN

A fire or explosion could result.

HOW TO AVOID THE HAZARD

Use only a nonflammable or high flash point solvent to clean ATV parts.

10. Soak the air cleaner an equivalent (gear oil: SAE 80 - 90) until saturated, then squeeze out the excess oil.

NOTE:

The element should be wet but not dripping.

CAUTION:

Twisting the air cleaner when squeezing out excess oil could damage the air cleaner.

11. Reassemble by reversing the disassembly sequence.

AIR CLEANER HOUSING DRAIN TUBE

The air cleaner housing drain tube should be serviced in accordance with the Maintenance Schedule. (Riding through water may require more frequent inspection.) If deposits can be seen in the drain tube, the tube must be cleaned before starting the vehicle.

To clean the drain tube:

1. Remove the drain tube (1) by removing the clip (3).
2. Drain the deposits.
3. Reinstall the drain tube, securing it with the clip.



- (1) Drain tube
(2) Air cleaner housing
(3) Clip

IDLE SPEED INSPECTION

NOTE:

A diagnostic tachometer must be used for this procedure.

1. Remove the seat (**see page 43**).
2. Start the engine and warm it up for a few minutes at approximately 1,000 to 2,000 r/min. Occasionally rev the engine to 4,000 to 5,000 r/min. The engine is warm when it quickly responds to the throttle.
3. Connect the tachometer and check the idle to the specified idling speed.

Specified idle speed:

1,400~1,600 rpm/min

THROTTLE LEVER ADJUSTMENT

NOTE:

Adjust the engine idling speed before adjusting the throttle lever free play.

To adjust throttle free play:

1. Slide the rubber sleeve (1) back to expose the throttle cable adjuster (2).
2. Loosen the lock nut (3), then turn the adjuster to obtain the correct free play. (3~5 mm or 0.12~0.2 in)
3. Tighten the locknut and reinstall the sleeve.

Other checks:

Check the throttle cable for kinks and signs of wear that could cause stretching or failure.

Lubricate the throttle cable with a commercially available lubricant to prevent premature wear and corrosion.

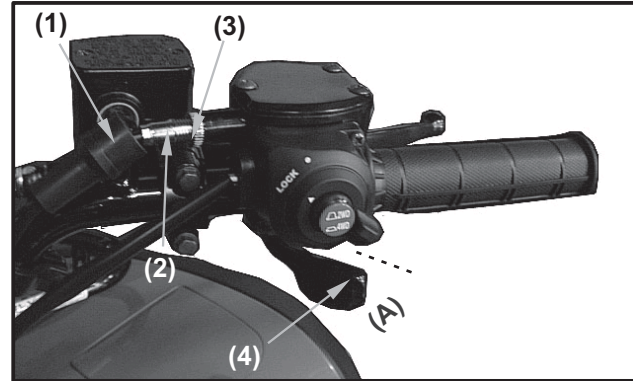

- (1) Rubber sleeve (2) Cable adjuster
(3) Locknut (4) Throttle lever
(A) 3~5 mm (0.12~0.2 in)

VALVE CLEARANCE ADJUSTMENT

The correct valve clearance changes with use, resulting in improper fuel/air supply or engine noise. To prevent this, the valve clearance must be adjusted regularly. This adjustment however, should be left to a professional KYMCO service technician.

FRONT BRAKE PADS INSPECTION

A wear indicator is provided on each brake. The indicators allows checking of brake pads wear. Check the position of the indicator. If the indicator reaches the wear limit line, ask a KYMCO dealer to replace the pads.

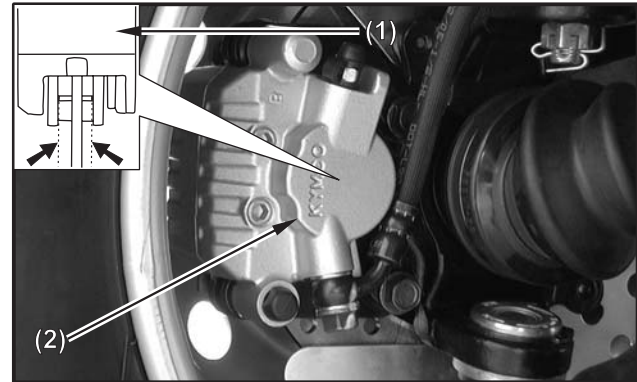

(1) Wear indicator

(2) Right/Left front brake

REAR BRAKE PADS INSPECTION

A wear indicator is provided on each brake. The indicators allows checking of brake pads wear. Check the position of the indicator. If the indicator reaches the wear limit line, ask a KYMCO dealer to replace the pads.

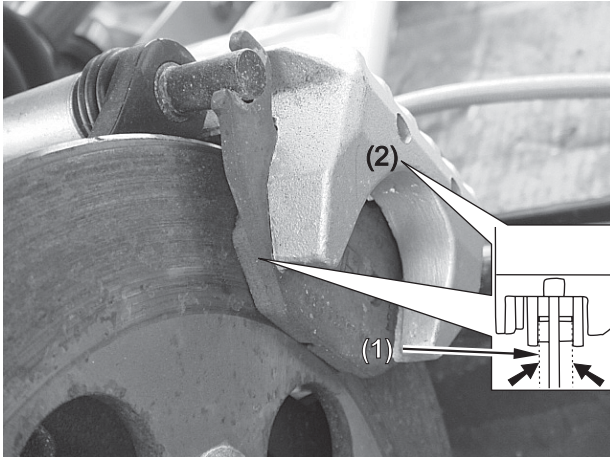

- (1) Wear indicator
- (2) Rear brakes

BRAKE FLUID INSPECTION

Check if the fluid level is below the lower level mark through the inspection window.

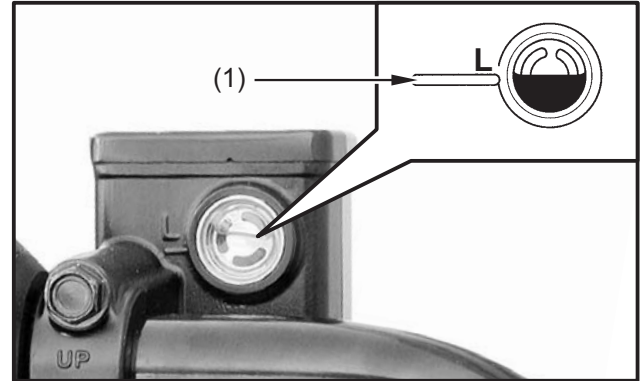

- (1) Lower level mark (Hand brake lever)

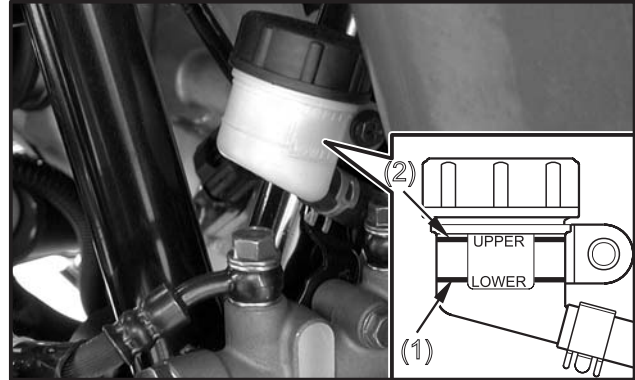

(1) Lower level mark (Foot brake pedal)

(2) Upper level mark (Foot brake pedal)

NOTE:

- As the brake pads wear, brake fluid level drops, automatically compensating for wear. There are no adjustments to perform, but fluid level and pad wear must be inspected periodically. The system must be inspected frequently to ensure there are no fluid leaks.
- If the brake lever travel become excessive and the brake pads are not worn beyond the recommended limit (**page 126~127**), There is probably air in the brake system and it must be bled. See your authorized KYMCO dealer for this service.

CAUTION:

- To prevent damage to the brake system, use only fluid from a sealed container. Never allow contaminants (dirt, water, etc.) to enter the brake fluid reservoir.
- Brake fluid can damage paint and plastic, so handle the fluid with care. When adding brake fluid, be sure the reservoir is horizontal before removing the cover to prevent accidental spilling.
- Use only DOT 4 brake fluid from a sealed container.

COOLING SYSTEM INSPECTION

1. Place the machine on the level ground. Remove the two fasteners (1) and then remove front cover (2).

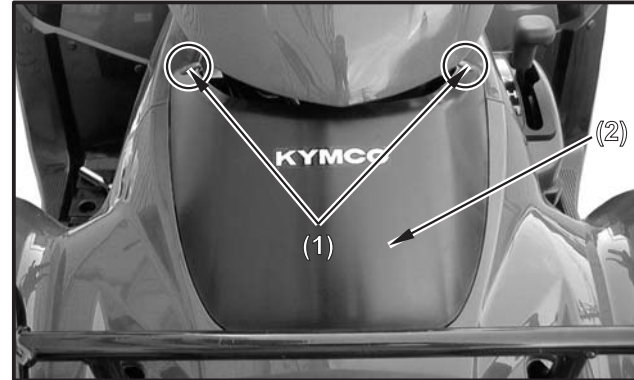

- (1) Fasteners
(2) Front cover

2. Check the coolant level in the coolant reservoir when the engine is cold as the coolant level will vary with engine temperature. The coolant level should be between the maximum and minimum marks.
3. If the level is low, remove the coolant reservoir cap, and then add coolant or distilled water to raise it to the specified level.
4. If your ATV overheats, see **page 131** for details.

CAUTION:

Hard water or salt water is harmful to the engine. You may use distilled water if you can not get soft water.

CAUTION:

Recommended Coolant Solution
Coolant Mixture Ratio:
Water 50%:Antifreeze 50%(1:1)

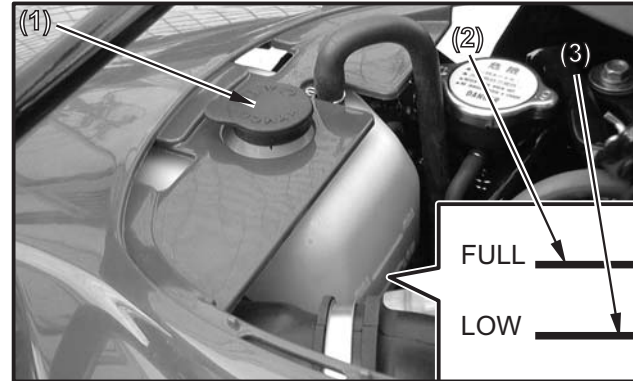

- (1) Coolant reservoir cap
- (2) Maximum level mark
- (3) Minimum level mark

NOTE:

1. If water is added, have a KYMCO dealer check the antifreeze content of the coolant as soon as possible.
2. The radiator fan operation is completely automatic. It is switched on or off according to the coolant temperature in the radiator.

Engine overheating

If your ATV overheats, wait until the engine has cooled.

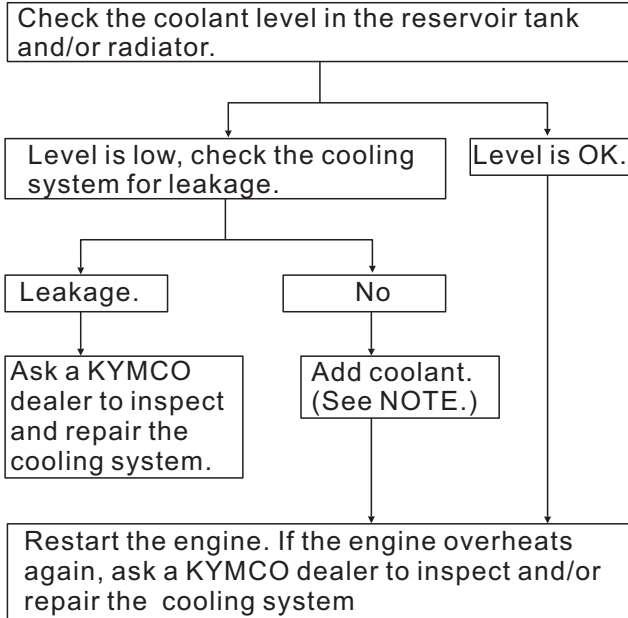

NOTE:

If it is difficult to get the recommended coolant, tap water can be temporarily used, provided that it is changed to the recommended coolant as soon as possible.



WARNING

POTENTIAL HAZARD

Removing the radiator cap when the engine and radiator are still hot.

WHAT CAN HAPPEN

You could be burned by hot fluid and steam blown out under pressure.

HOW TO AVOID THE HAZARD

Wait for the engine to cool before removing the radiator cap. Always use a thick rag over the cap. Allow any remaining pressure to escape before completely removing the cap.

Should be serviced by your authorized KYMCO dealer when changing the coolant.

WHEEL REMOVAL

1. Elevate the wheel by placing a suitable stand under the frame.
2. Remove the nuts from the wheel.
3. Remove the wheel assembly.



(1) Wheel nuts



WHEEL INSTALLATION

When reinstalling a wheel, tighten the wheel nuts in a crisscross (rather than a circular) pattern. Be sure the tapered side of the wheel nuts (1) face the wheel rim (2).

Wheel nut torque:

Front: 61 N-m (6.1 kgf-m, 43.9 lbf-ft)

Rear: 61 N-m (6.1 kgf-m, 43.9 lbf-ft)

Be sure the tapered side of the wheel nuts (1) face the wheel rim (2).

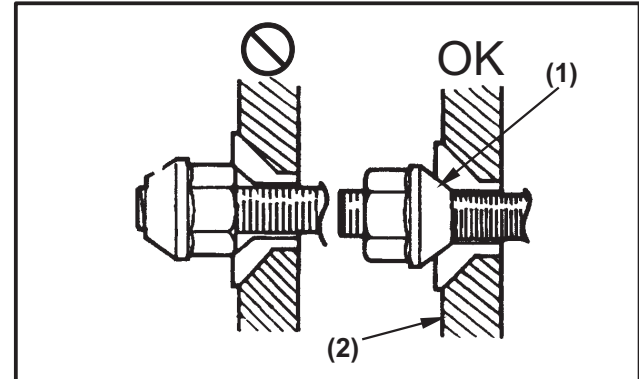

(1) Wheel nut

(2) Wheel rim

NOTE:

The arrow mark  on the tire must point toward the rotating direction of the wheel.

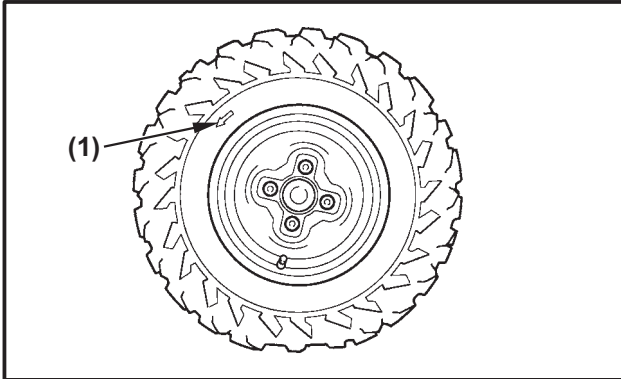

(1) Arrow mark

 **WARNING**

POTENTIAL HAZARD
Installing wheels improperly.

WHAT CAN HAPPEN
A wheel may come loose, possibly leading to an accident.

HOW TO AVOID THE HAZARD
Carefully follow the instructions in this Owner's Manual when installing.

BATTERY

Your ATV battery is located in a compartment under the seat. The battery is sealed, so it is not necessary to check the electrolyte level or add distilled water. If the battery seems weak, see your authorized KYMCO dealer for information on recharging or replacement. If you replace the battery, choose one that is sealed and equivalent to the original. Be sure to read and follow all safety precautions indicated on the battery.

CAUTION:

- Do not attempt to remove the caps from the battery cells as this may damage the battery.
- Although the battery is sealed, it vents explosive gases and should be handled with appropriate care.

WARNING

POTENTIAL HAZARD

Allowing open flames or sparks near the battery.

WHAT CAN HAPPEN

Gases may explode and possibly cause injury.

HOW TO AVOID THE HAZARD

Do not allow open flames or sparks near the battery.

NOTE:

- When the ATV is to be stored for an extended period, remove the battery from the vehicle and charge it fully. Then store it in a cool, dry place. If the battery is to be left on the vehicle, disconnect the negative cable from the battery terminal.
- Battery posts, terminals and related accessories contain lead and lead compounds. **Wash hands after handling.**

Battery remove

1. Make sure the ignition switch is OFF.
2. Remove the seat (**page 43**)
3. Release the rings and remove the rubber band (1).
4. Disconnect the negative (-) terminal lead (2) from the battery first, then disconnect the positive (+) terminal lead (3).
5. Remove the battery.

Battery installation

1. Install in the reverse order of removal.
2. After installing the battery, check to see if the battery cables are routed correctly.

NOTE:

First connect the positive (+) cable and then negative (-) cable to avoid short circuit.

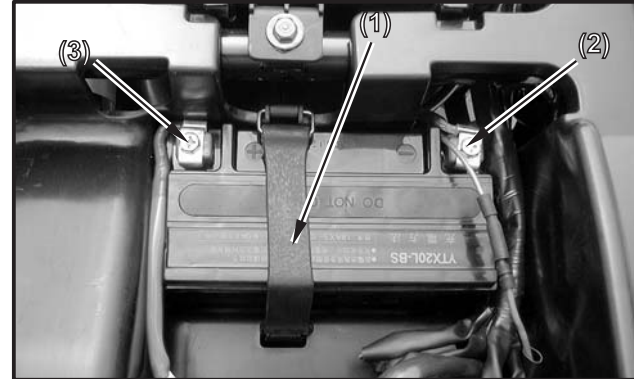

- (1) Rubber band
- (2) Negative terminal lead
- (3) Positive terminal lead

FUSE REPLACEMENT

The fuse box (1) stored in the battery compartment under the seat.

To replace a fuse:

1. Make sure the ignition switch is OFF.

CAUTION:

To prevent accidental short-circuiting, turn off the main switch when checking or replacing a fuse.

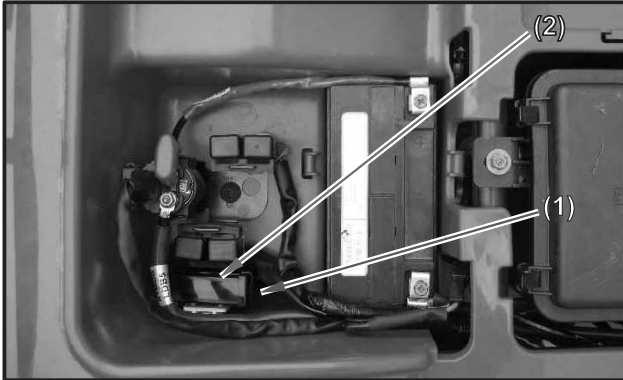

(1) Fuse box (2) Fuse box cap

2. Remove the seat (**page 43**)
3. Open the fuse box cap (2).
4. Pull the old fuse out of the fuse holder.
5. Push the new fuse in to the fuse holder.
6. Close the fuse box cap and install seat.

⚠ WARNING

POTENTIAL HAZARD

Using an improper fuse.

WHAT CAN HAPPEN

An improper fuse can cause damage to the electrical system which could lead to a fire.

HOW TO AVOID THE HAZARD

Always use a fuse of the specified rating.
Never use a material in place of the proper fuse.

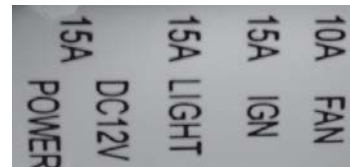

Fuse specifications

HEADLIGHT BEAM ADJUSTMENT

CAUTION:

It is advisable to have a KYMCO dealer make this adjustment.

To adjust:

Turn the ignition switch at "  " position and start the engine.

Turn on the dimmer switch.

Adjust the headlight aim by turning the headlight aim adjusting screws.

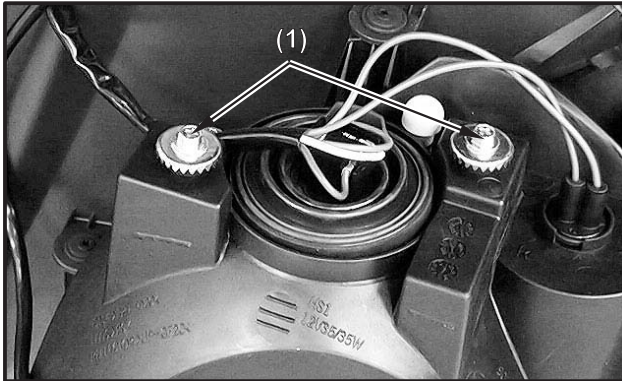

(1) Adjusting screws

DRIVE SHAFT BOOTS

Check the protective boots for holes or tears.

If any damage is found, have them replaced by a KYMCO dealer

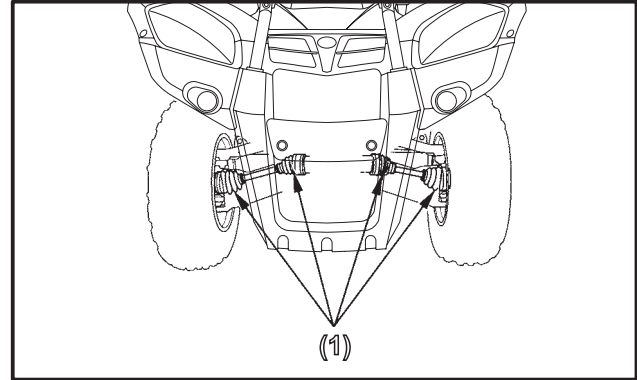

(1) Drive shaft boots

CABLE INSPECTION AND LUBRICATION



WARNING

POTENTIAL HAZARD

Damaged control cables.

WHAT CAN HAPPEN

Corrosion can result when the outer covering of control cables becomes damaged.

Cables can also become frayed or kinked. Operation of controls could be restricted, which could cause an accident or injury.

HOW TO AVOID THE HAZARD

Inspect cables frequently. Replace damaged cables.

Lubricate the inner cables and the cable ends. If the cables do not operate smoothly, ask a KYMCO dealer to replace them.

Recommended lubricant:

KYMCO chain and cable lube or
SAE 10W40 motor oil

TROUBLESHOOTING

Although KYMCO machines receive a rigid inspection before shipment from the factory, trouble may occur during operation. Any systems can cause poor starting and loss of power. The troubleshooting chart describes a quick, easy procedure for making checks. If your machine requires any repair, take it to a KYMCO dealer.

The skilled technicians at a KYMCO dealership have the tools, experience, and know-how to properly service your machine. Imitation parts may look like KYMCO parts, but they are often inferior. Consequently, they have a shorter service life and can lead to expensive repair bills.

WARNING

POTENTIAL HAZARD

Checking the fuel system while smoking or near an open flame.

WHAT CAN HAPPEN

Fuel can ignite or explode, causing severe injury or property damage.

HOW TO AVOID THE HAZARD

Do not smoke when checking the fuel system. Make sure there are no open flames or sparks in the area, including pilot lights from water heaters or furnaces.

Troubleshooting chart

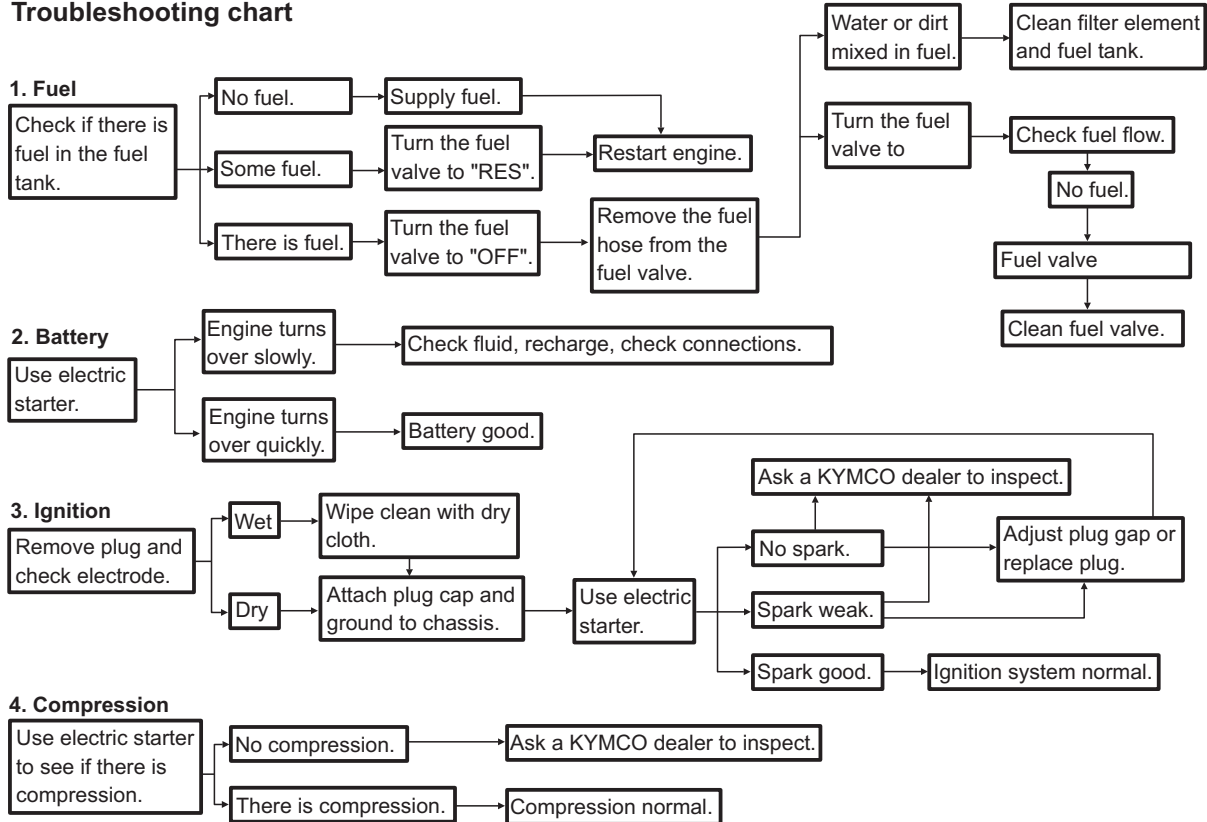

CLEANING AND STORAGE

A. CLEANING

Frequent, thorough cleaning of your machine will not only enhance its appearance but will improve its general performance and extend the useful life of many components.

1. Before cleaning the machine:
 - A. Block off the end of the exhaust pipe to prevent water entry. A plastic bag and strong rubber band may be used.
 - B. Make sure the spark plug and all filler caps are properly installed.
2. If the engine case is excessively greasy, apply degreaser with a paint brush. Do not apply degreaser to the chain, sprockets or wheel axles.
3. Rinse the dirt and degreaser off with a garden hose. Use only enough pressure to do the job.

CAUTION:

Excessive water pressure may cause water seepage and deterioration of wheel bearings, brakes, transmission seals and electrical devices. Many expensive repair bills have resulted from improper high pressure detergent applications such as those available in coin-operated car washers.

4. Once the majority of the dirt has been hosed off, wash all surfaces with warm water and mild, detergent-type soap. An old toothbrush or bottle brush is handy for hard-to-get-at places.
5. Rinse the machine off immediately with clean water and dry all surfaces with a chamois, clean towel or soft absorbent cloth.
6. Dry the chain and lubricate it to prevent rust.

7. Clean the seat with a vinyl upholstery cleaner to keep the cover pliable and glossy.
8. Automotive type wax may be applied to all painted and chrome plated surfaces. Avoid combination cleaner-waxes. Many contain abrasives which may mar the paint or protective finish.
When finished, start the engine and let it idle for several minutes.

 **WARNING**

POTENTIAL HAZARD

Operation with wet brakes after washing.

WHAT CAN HAPPEN

Wet brakes may have reduced stopping ability, increasing the chance of an accident.

HOW TO AVOID THE HAZARD

Test the brakes after washing. Apply the brakes several times at slow speeds to let friction dry out the linings.

B. STORAGE

Before storing your ATV for an extended time, be sure you thoroughly check the vehicle for needed repairs and have them corrected. Otherwise, the repairs may be forgotten by the time you remove the vehicle from storage.

In addition, extended storage requires that you take the following steps to reduce the effects of deterioration from non-use of the vehicle:

1. Change the engine oil.
2. Drain the fuel tank and carburetor. Be sure to drain the fuel in a well-ventilated area, not in a garage.

WARNING

POTENTIAL HAZARD

Refueling this ATV or handling fuel improperly.

WHAT CAN HAPPEN

The fuel could explode or ignite.

HOW TO AVOID THE HAZARD

Always refuel this ATV and handle fuel in a well-ventilated area with the engine off. Do not smoke or allow flames or sparks in the area where fuel is handled.

Do not overfill the tank. Be careful not to spill fuel when refueling. After refueling, make sure the fuel fill cap is closed properly and securely.

If any fuel is spilled, make sure the area is dry before starting the engine.



WARNING

POTENTIAL HAZARD

**Prolonged contact of fuel with the skin.
Breathing fuel vapor.**

WHAT CAN HAPPEN

**The fuel can cause skin irritation.
Fuel vapor could cause lung damage.**

HOW TO AVOID THE HAZARD

**Avoid repeated or prolonged contact of fuel
with the skin or breathing of fuel vapor.**

KEEP OUT OF REACH OF CHILDREN.

3. Remove the spark plug and pour one tablespoon (15 - 20 cc) of clean engine oil into the cylinder. Operate the starter for a few seconds to distribute the oil, then reinstall the spark plug.

4. Remove the battery (**page 135**) and store it in an area protected from freezing temperatures and direct sunlight and out of the reach of children, slow charge the battery once a month.



WARNING

POTENTIAL HAZARD

**Allowing open flames or sparks near the
battery.**

WHAT CAN HAPPEN

**Gases may explode and possibly cause
injury.**

HOW TO AVOID THE HAZARD

**Do not allow open flames or sparks near the
battery.**

5. Wash and dry the ATV, and wax all painted surfaces.
6. Inflate the tires to their recommended pressures.
7. Place the ATV on blocks to raise all four tires off the ground.

SPECIFICATIONS

Model	MXU 500i IRS
Dimension: Overall length Overall width Overall height Seat height Wheel base Minimum ground clearance Minimum turning radius	2203 mm (88.12 in) 1223 mm (48.92 in) 1243 mm (49.72 in) 887 mm (35.48 in) 1297 mm (51.88 in) 241 mm (9.64 in)
Basic weight: With oil and full fuel tank	335 kg (737 lbs)
Engine: Type Cylinder arrangement: Displacement Bore x stroke Compression ratio Starting system Lubrication system:	Liquid cooled 4-stroke, DOHC Single cylinder 498.5 cc 92X75 mm (3.68X3 in) 10.5:1 Electric Wet sump

Model	MXU 500i IRS
<p>Engine oil/transmission oil/ rear final gear case oil:</p> <p>Type</p> <p>Engine oil classification:</p> <p>Front gear box oil classification:</p> <p>Rear gear box oil classification:</p> <p>Quantity</p> <p>Engine oil:</p> <p> Periodic oil change</p> <p> After draining and oil filter cartridge change</p> <p> Total amount</p> <p>Front gear case oil:</p> <p> Periodic oil change</p> <p> Total amount</p> <p>Rear gear case oil:</p> <p> Periodic oil change</p> <p> Total amount</p>	<div data-bbox="1018 176 1246 395" data-label="Figure"> </div> <p data-bbox="887 400 1267 428">API Service SJ type or higher</p> <p data-bbox="1078 471 1187 493">SAE#80</p> <p data-bbox="1078 499 1187 521">SAE#80</p> <p data-bbox="954 650 1315 673">3 L (2.64 Imp qt, 3.18 US qt)</p> <p data-bbox="954 686 1342 708">3.2 L (2.82 Imp qt, 3.39 US qt)</p> <p data-bbox="954 722 1342 744">3.6 L (3.17 Imp qt, 3.82 US qt)</p> <p data-bbox="954 792 1374 815">0.25 L (0.22 Imp qt, 0.265 US qt)</p> <p data-bbox="954 828 1390 851">0.27 L (0.238 Imp qt, 0.286 US qt)</p> <p data-bbox="954 899 1374 921">0.23 L (0.20 Imp qt, 0.243 US qt)</p> <p data-bbox="954 935 1374 957">0.25 L (0.22 Imp qt, 0.265 US qt)</p>

Model	MXU 500 i IRS
Air filter: for engine for V-belt compartment	Wet type element Dry type element
Fuel: Type Tank capacity Reserve amount	UNLEADED FUEL 16.5 L (3.47 Imp gal, 4.29 US gal) 2.3 L (0.48 Imp gal, 0.6 US gal)
Throttle body: Type	PTA1/KYMCO
Spark plug: Type Gap	CR7E (NGK) 0.6 ~ 0.7 mm (0.024 ~ 0.028 in)
Clutch: Type	Wet, centrifugal automatic
Brake: Front brake type Rear brake type	Disk brake/Dual Disc brake Disk brake/Single Disc brake

Model	MXU 500i IRS
Suspension: Front Rear	Dual A-arm Dual A-arm
Shock absorber: Front Rear	Coil spring/Oil damper Coil spring/Oil damper
Electrical: Ignition system Generator system Battery type	ECU automatic control A.C. magneto 12V, 18AH MF
Tire: Type Size: Front Rear	Tubeless 25X8-12 25X10-12
Bulb voltage, wattage*quantity: Headlight Brake light/Taillight Turn signal light Position light	12V35W/35W X2 12V21W/5W X2 12V10WX4 12V5WX2

NOISE REGULATION

TAMPERING WITH NOISE CONTROL SYSTEM PROHIBITED:

Some local laws and regulations prohibit the following acts or the causing thereof: (1) The removal or rendering inoperative by any person other than for purposes of maintenance, repair, or replacement of any device or element of design incorporated into any new vehicle for the purpose of noise control prior to its sale or delivery to the ultimate purchaser or while it is in use or (2) the use of the vehicle after such device or element of design has been removed or rendered inoperative by any person.

"AMONG THOSE ACTS PRESUMED TO CONSTITUTE TAMPERING ARE THE ACTS LISTED BELOW".

Exhaust system	Muffler Exhaust pipe Silencer
Intake system	Air cleaner case Air cleaner element Intake duct

MAINTENANCE RECORD

Copies of work orders and/or receipts for parts you purchase and install will be required to document maintenance done in accordance with the warranty. The chart below is printed only as a reminder to you that the maintenance work is required. It is not acceptable proof of maintenance work.

MAINTENANCE INTERVAL	DATE OF SERVICE	MONTH	SERVICING DEALER NAME AND ADDRESS	REMARKS
150 km				
1000 km				
2000 km				
3000 km				
4000 km				
5000 km				
6000 km				
7000 km				
8000 km				
9000 km				
10000 km				

KWANG YANG MOTOR CO.,LTD.
NO.35 Wan Hsing Street, San Min District
Kaohsiung, Taiwan, Republic of China
Telephone : 886-7-3822526
FAX : 886-7-3950021

By KWANG YANG Motor Co., Ltd.
First Edition, JAN 2010
All rights reserved. Any reproduction or
unauthorized use without the written permission of
KWANG YANG Motor Co., Ltd.
is expressly prohibited.
T200-LDA0AD-IT-A1



KWANG YANG MOTER CO .,LTD
NO.35 Wan Hsing Street, San Min District
Kaohsiung, Taiwan, Republic Of China
Telephone : 886-7-3822526
Fax : 886-7-3950021

Printed in Taiwan